

Ovation

B-565FC

User Manual

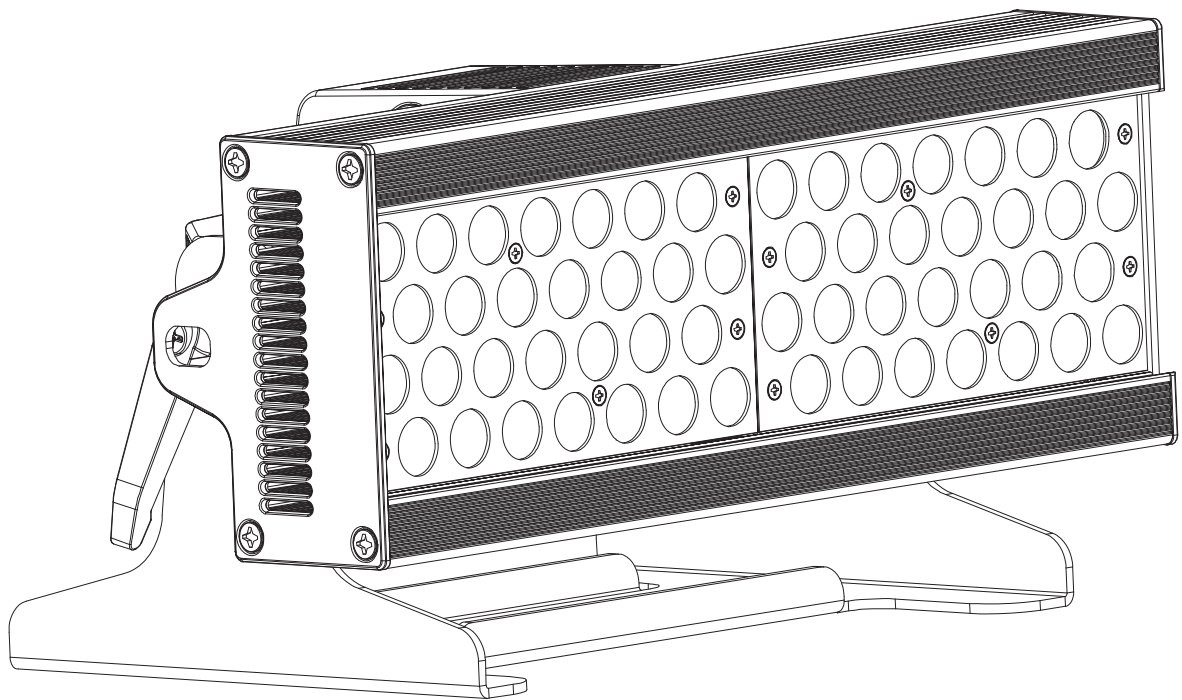

CHAUVET
PROFESSIONAL

Edition Notes

The Ovation B-565FC User Manual includes a description, safety precautions, installation, programming, operation and maintenance instructions for the Ovation B-565FC as of the release date of this edition.

Trademarks

CHAUVET, the Chauvet logo and Ovation B-565FC are registered trademarks or trademarks of Chauvet & Sons, LLC (d/b/a Chauvet and Chauvet Lighting) in the United States and other countries. Other company and product names and logos referred to herein may be trademarks of their respective companies.

Copyright Notice

The works of authorship contained in this manual, including, but not limited to, all design, text and images are owned by Chauvet.

© **Copyright 2020 Chauvet & Sons, LLC. All rights reserved.**

Electronically published by Chauvet in the United States of America.

Manual Use

Chauvet authorizes its customers to download and print this manual for professional information purposes only. Chauvet expressly prohibits the usage, copy, storage, distribution, modification, or printing of this manual or its content for any other purpose without written consent from Chauvet.

Document Printing

For best results, print this document in color, on letter size paper (8.5 x 11 in), double-sided. If using A4 paper (210 x 297 mm), configure the printer to scale the content accordingly.

Intended Audience

Any person installing, operating, and/or maintaining this product should completely read through the guide that shipped with the product, as well as this manual, before installing, operating, or maintaining this product.

Disclaimer

Chauvet believes that the information contained in this manual is accurate in all respects. However, Chauvet assumes no responsibility and specifically disclaims any and all liability to any party for any loss, damage or disruption caused by any errors or omissions in this document, whether such errors or omissions result from negligence, accident or any other cause. Chauvet reserves the right to revise the content of this document without any obligation to notify any person or company of such revision, however, Chauvet has no obligation to make, and does not commit to make, any such revisions. Download the latest version from www.chauvetprofessional.com.

Document Revision

This Ovation B-565FC User Manual is the 6th edition of this document. Go to www.chauvetprofessional.com for the latest version.

TABLE OF CONTENTS

1. Before You Begin	1
What Is Included	1
Claims	1
Manual Conventions	1
Symbols	1
Safety Notes.....	2
Personal Safety.....	2
Mounting and Rigging	2
Power and Wiring.....	2
Operation	2
Expected LED Lifespan.....	2
2. Introduction	3
Description	3
Features.....	3
Product Overview.....	4
Product Dimensions.....	5
3. Setup	6
AC Power.....	6
AC Plug.....	6
Power Linking.....	6
Signal Connections	6
DMX Connection.....	6
Art-Net™ Connection.....	6
sACN Connection.....	6
Connection Diagram	7
Remote Device Management (RDM).....	7
Master/Slave Connectivity.....	7
Mounting	8
Orientation.....	8
Rigging.....	8
Procedure.....	8
4. Operation	9
Control Panel Operation.....	9
Programming.....	9
Menu Map	9
Configuration (DMX/Art-Net™/sACN).....	12
Control Protocol	12
Ethernet Setting	12
Control Personalities	13
Starting Address.....	13
DMX Values	14
2-Cell Personalities	14
1-Cell Personalities	18
Virtual Color Wheel	21

Configuration (Standalone)	22
Static Mode	22
Auto Programs	22
Red Shift	22
Master/Slave	23
Dimmer Curve	23
Dimmer Profiles	23
White Balance	23
LED Frequency	23
Display Orientation	23
Back Light	24
System Information	24
Factory Reset	24
Web Server	24
Home	24
Settings	24
Output	24
Security	24
5. Technical Information	25
Product Maintenance	25
6. Technical Specifications	26
Returns	27
Contact Us	28

1. Before You Begin

What Is Included

- Ovation B-565FC
- Neutrik® powerCON® power cord
- Wall washing filter
- Quick Reference Guide

Claims

Carefully unpack the product immediately and check the container to make sure all the parts are in the package and are in good condition.





If the box or the contents (the product and included accessories) appear damaged from shipping, or show signs of mishandling, notify the carrier immediately, not Chauvet. Failure to report damage to the carrier immediately may invalidate your claim. In addition, keep the box and contents for inspection.

For other issues, such as missing components or parts, damage not related to shipping, or concealed damage, file a claim with Chauvet within 7 days of delivery.

Manual Conventions

Convention	Meaning
1–512	A range of values
50/60	A set of values of which only one can be chosen
<SET>	A button on the product’s control panel
Settings	A product function or a menu option

Symbols

Symbol	Meaning
	Electrical warning. Not following these instructions may cause electrical damage to the product, accessories, or the user.
	Critical installation, configuration, or operation information. Not following these instructions may make the product not work, cause damage to the product, or cause harm to the operator.
	Important installation or configuration information. The product may not function correctly if this information is not used.
	Useful information.



The term “DMX” used throughout this manual refers to the USITT DMX512-A digital data transmission protocol.

FCC Compliance

This device complies with Part 15 Part B of the FCC Rules. Operation is subject to the following two conditions:

1. This device may not cause harmful interference, and
2. This device must accept any interference received, including interference that may cause undesired operation.

Any changes or modifications not expressly approved by the party responsible for compliance could void the user's authority to operate the equipment.

Safety Notes

Read all the following safety notes before working with this product. These notes contain important information about the installation, usage, and maintenance of this product.



This product contains no user-serviceable parts. Any reference to servicing in this User Manual will only apply to properly trained, certified technicians. Do not open the housing or attempt any repairs.



All applicable local codes and regulations apply to proper installation of this product.

Personal Safety

- Avoid direct eye exposure to the light source while the product is on.
- Always disconnect the product from the power source before cleaning or replacing the fuse.
- Always connect the product to a grounded circuit to avoid the risk of electrocution.
- Do not touch the product's housing when operating because it may be very hot.

Mounting and Rigging

- This product is not intended for permanent installation.
- This product is for indoor use only! To prevent risk of fire or shock, do not expose this product to rain or moisture (IP20).
- CAUTION: When transferring product from extreme temperature environments, (e.g., cold truck to warm, humid ballroom) condensation may form on the internal electronics of the product. To avoid causing a failure, allow product to fully acclimate to the surrounding environment before connecting it to power.
- Mount this product in a location with adequate ventilation, at least 20 in (50 cm) from adjacent surfaces.
- Make sure there are no flammable materials close to the product when operating.
- When hanging this product, always secure to a fastening device using a safety cable.

Power and Wiring

- Always make sure you are connecting the product to the proper voltage in accordance with the specifications in this manual or on the product's specification label.
- To eliminate unnecessary wear and improve its lifespan, during periods of non-use completely disconnect the product from power via breaker or by unplugging it.
- Make sure to replace the fuse with another of the same type and rating.
- Never connect the product to a dimmer pack or rheostat.
- Never disconnect this product by pulling or tugging on the power cable.

Operation

- The luminaire should be positioned so that prolonged staring into the luminaire at a distance closer than 2.3 m is not expected.
- If the external flexible cable or cord of this luminaire is damaged, it shall be replaced by a special cord or cord exclusively available from the manufacturer or his service agent.
- The light source contained in this luminaire shall only be replaced by the manufacturer or his service agent or a similar qualified person.
- The luminaire is intended for professional use only.
- Do not operate this product if there is damage on the housing, lenses, or cables. Have the damaged parts replaced by an authorized technician at once.
- Do not cover the ventilation slots when operating to avoid internal overheating.
- The maximum ambient temperature is 113 °F (45 °C). Do not operate the product at higher temperatures.
- In the event of a serious operation problem, stop using this product immediately!



If your Chauvet product requires service, contact Chauvet Technical Support.

Expected LED Lifespan

Over time, use and heat will gradually reduce LED brightness. Clustered LEDs produce more heat than single LEDs, contributing to shorter lifespans if always used at full intensity. The average LED lifespan is 40,000 to 50,000 hours. To extend LED lifespan, maintain proper ventilation around the product, and limit the overall intensity.

2. Introduction

Description

The Ovation B-565FC is a high-power full-color LED (RGBAL) batten. It features full RGBA-Lime color mixing with modes, providing full 16-bit dimming for 1 or 2 cells, selectable PWM, RDM, Art-Net™, and sACN. The Virtual Color Wheel matches popular gel colors comparable with those projected by a tungsten source, and color temperature presets that match a tungsten source from 2800 to 6500 K. Enhance the product's wall-washing ability with the included holographic filter.

Features

- Full-color LED (RGBAL) batten fixture for theatre, film, and production
- Theatre-ready with 16-bit dimming of master dimmer and individual colors
- Multiple control personalities one or two sections of control
- Included holographic filter locks in place for ultra-smooth color mixing with a more elliptical wash pattern
- Virtual Color Wheel with color matched to popular gel colors
- Art-Net™, sACN, 3- and 5-pin DMX, and RDM (Remote Device Management) for added control flexibility
- Neutrik® powerCON® and Amphenol etherCON® compatible connections for power and data linking
- Adjustable PWM (Pulse Width Modulation) to avoid flickering on camera
- Nearly silent operation for use in studio and theatre applications

Product Overview

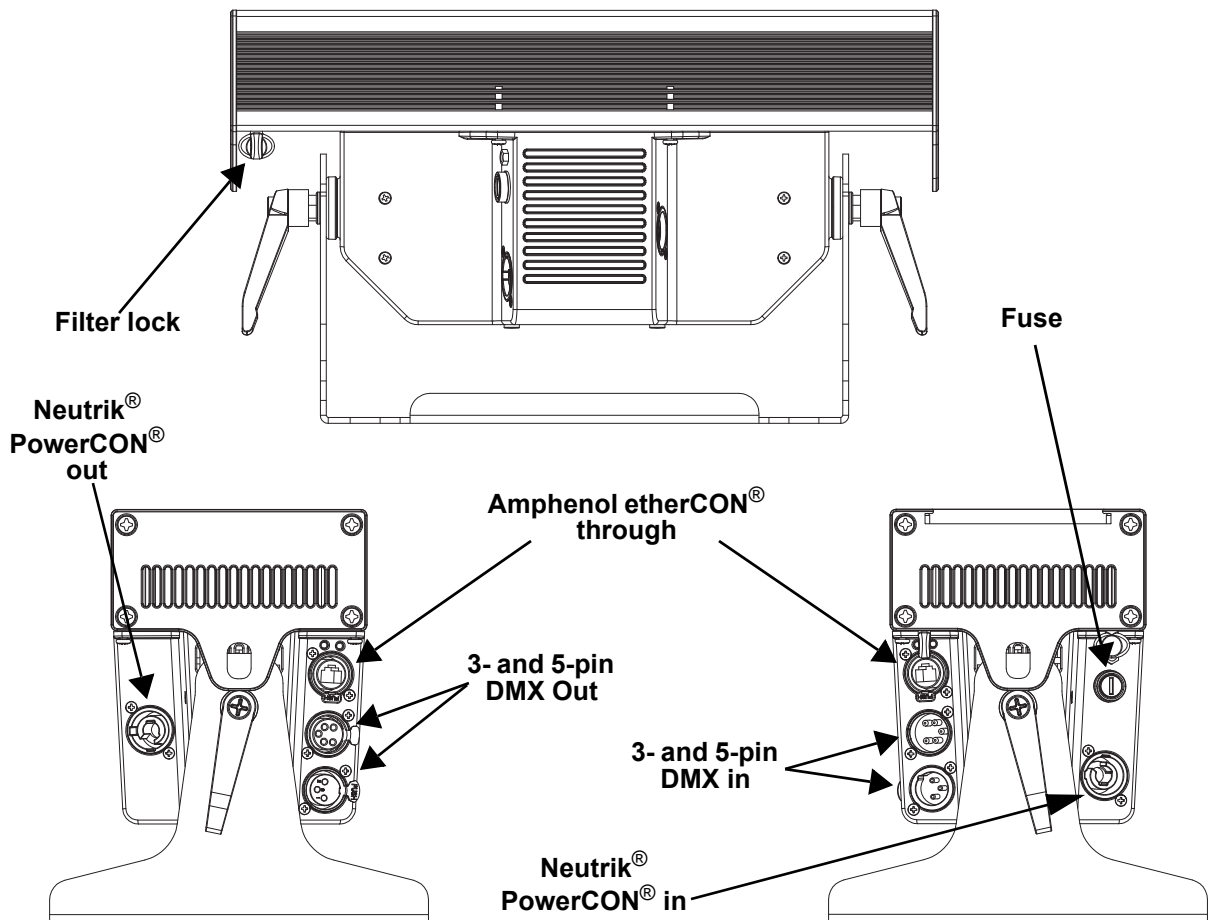
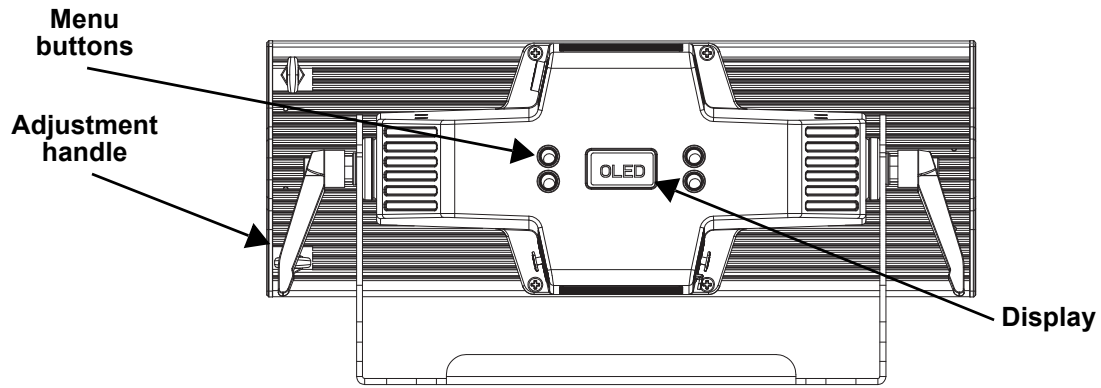

Product Dimensions

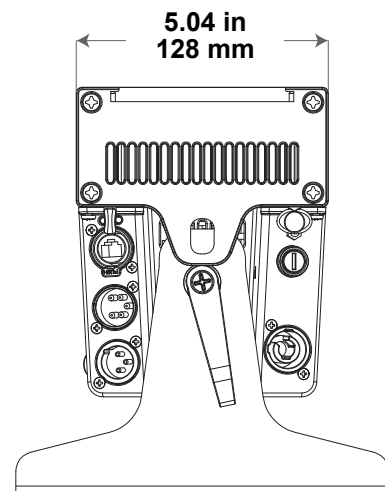
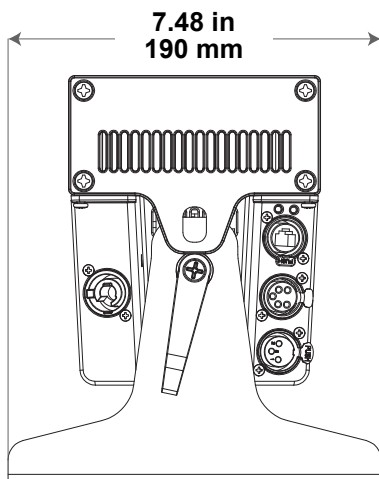
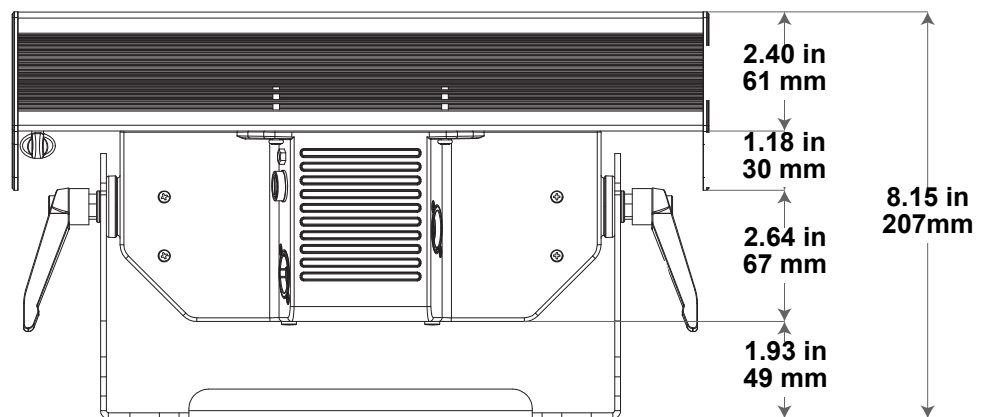
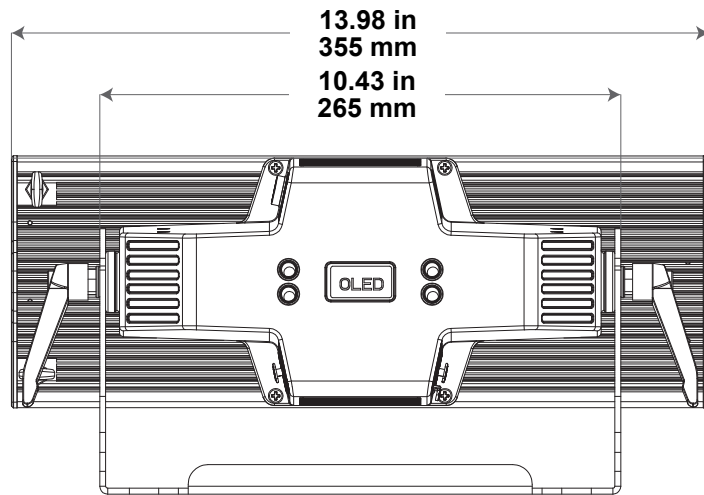

3. Setup

AC Power

Each Ovation B-565FC has an auto-ranging power supply that works with an input voltage range of 100 to 240 VAC, 50/60 Hz. To determine the power requirements for each Ovation B-565FC, refer to the label affixed to the product. You can also refer to the [Technical Specifications](#) chart in this manual.

The listed current rating indicates the maximum current draw during normal operation. For more information, download Sizing Circuit Breakers from the Chauvet website: www.chauvetprofessional.com.



- **Always connect the product to a protected circuit (e.g., circuit breaker or fuse). Make sure the product has an appropriate electrical ground to avoid the risk of electrocution or fire.**
- **To eliminate unnecessary wear and improve its lifespan, during periods of non-use completely disconnect the product from power via breaker or by unplugging it.**



Never connect the product to a rheostat (variable resistor) or dimmer circuit, even if the rheostat or dimmer channel serves only as a 0 to 100% switch.

AC Plug

The Ovation B-565FC comes with a power input cord terminated with a Neutrik® powerCON® connector on one end and an Edison plug on the other end (US market). If the power input cord that came with your product has no plug, or if you need to change the plug, use the table below to wire the new plug.

Connection	Wire (U.S.)	Wire (Europe)	Screw Color
AC Live	Black	Brown	Yellow or Brass
AC Neutral	White	Blue	Silver
AC Ground	Green/Yellow	Green/Yellow	Green

Power Linking

The product supports power linking. You can power link up to 13 products at 120 V; up to 22 at 208 V; or up to 23 at 230 V. This product comes with a power input cord. Power-linking cables are available from Chauvet for purchase.

Signal Connections

The Ovation B-565FC uses DMX, Art-Net™, or sACN for the 33 control personalities, ranging from 3-channel to 31-channel. The Ovation B-565FC has 2 Amphenol etherCON® through ports and both 3- and 5-pin DMX in and out ports.

- Refer to the [Operation](#) chapter to learn how to configure the Ovation B-565FC to work in these personalities.
- The [DMX Values](#) section provides detailed information regarding the control personalities.



If you are not familiar with or need more information about DMX standards, Master/ Slave connectivity, or the DMX cables needed to link this product to a DMX controller, download the DMX Primer from the Chauvet website:
http://www.chauvetlighting.com/downloads/DMX_Primer_rev05_WO.pdf.

DMX Connection

You can link the Ovation B-565FC to a DMX controller using a 3- or 5-pin DMX connection. If using other DMX-compatible products with this product, you can control each individually with a single DMX controller.

Art-Net™ Connection

Art-Net™ is an Ethernet protocol that uses TCP/IP, which transfers a large amount of DMX512 data using a Neutrik® etherCON® RJ45 connection over a large network. An Art-Net™ protocol document is available from www.chauvetprofessional.com.

Art-Net™ designed by and copyright Artistic Licence Holdings Ltd.

sACN Connection

Kling-Net is a network protocol that allows auto configuration of display devices using a Neutrik® etherCON® RJ45 Ethernet connection. Refer to the ArKaos software manual for detailed instructions on programming this product.

Connection Diagram

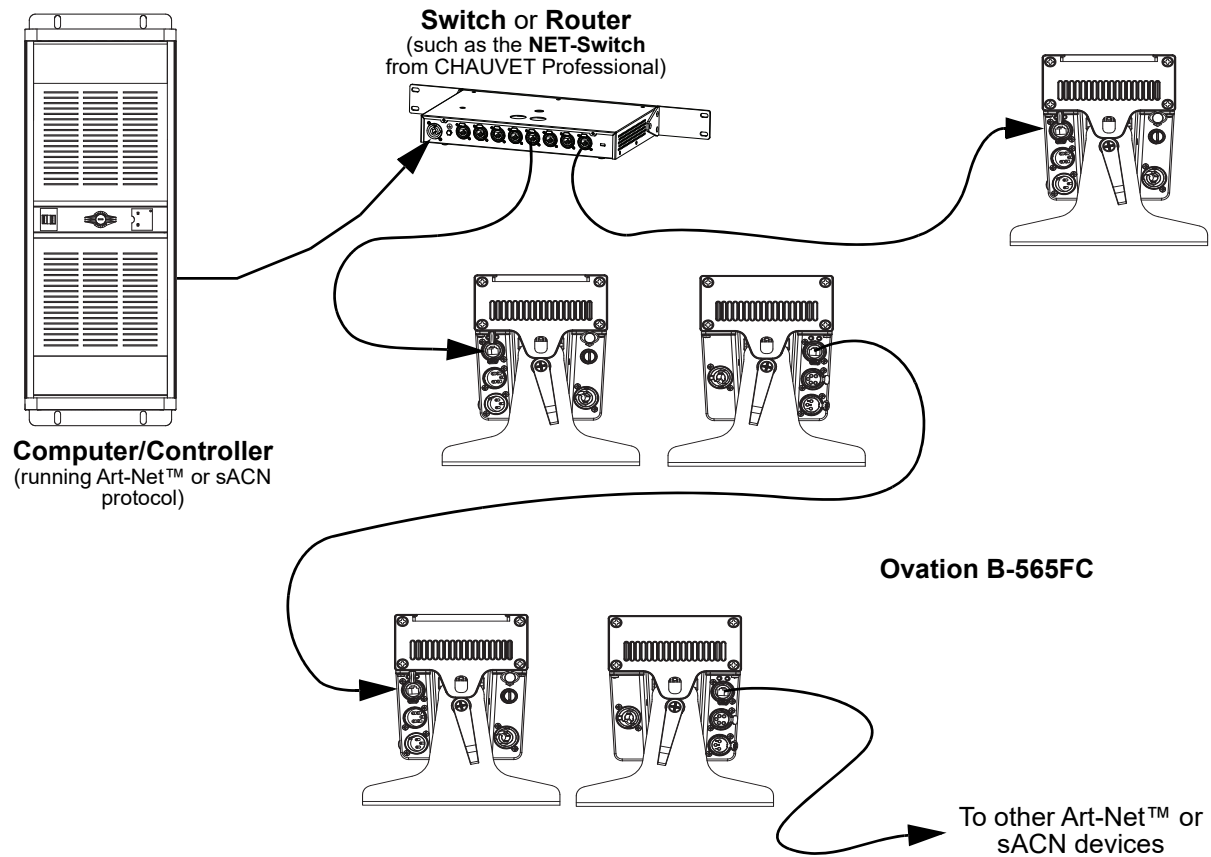

Remote Device Management (RDM)

Remote Device Management, or RDM, is a standard for allowing DMX-enabled devices to communicate bi-directionally along existing DMX cabling. Check the DMX controller's User Manual or with the manufacturer, as not all DMX controllers have this capability. The Ovation B-565FC supports RDM protocol that allows feedback to make changes to menu map options.

Master/Slave Connectivity

The Master/Slave mode allows an Ovation B-565FC (the master) to control one or more Ovation B-565FC products (the slaves) without a DMX controller. One Ovation B-565FC becomes the master when running an auto or custom program, or by being in a Static mode.

You must configure each slave's control panel to operate in Slave mode. During Master/Slave operation, the slaves will operate in unison with the master.



DO NOT connect a DMX controller to products operating in Master/Slave mode. The DMX controller signals may interfere with the signals from the master.



- The [Operation](#) section of this manual provides detailed instructions on how to configure the master and slaves.
- If you are not familiar with or need more information about DMX standards, or the DMX cables needed to link this product to a DMX controller, download the DMX Primer from the Chauvet website: http://www.chauvetlighting.com/downloads/DMX_Primer_rev05_WO.pdf.

Mounting

Before mounting the product, read and follow the safety recommendations indicated in the [Safety Notes](#). For our CHAUVET Professional line of mounting clamps, go to <http://trusst.com/products/>.

Orientation

Always mount this product in a safe position, making sure there is adequate room for ventilation, configuration, and maintenance.

Rigging

Chauvet recommends using the following general guidelines when mounting this product.

- Before deciding on a location for the product, make sure there is easy access to the product for maintenance and programming purposes.
- Make sure that the structure onto which you are mounting the product can support the product's weight. See the [Technical Specifications](#) for weight information.
- When mounting the product overhead, always use a safety cable. Mount the product securely to a rigging point, whether an elevated platform or a truss.
- When rigging the product onto a truss, use a mounting clamp of appropriate weight capacity.
- When power linking multiple products, mount the products close enough for power-linking cables to reach.
- The bracket adjustment knobs allow for directional adjustment when aiming the product to the desired angle. Only loosen or tighten the bracket knobs manually. Using tools could damage the knobs.

Procedure

The Ovation B-565FC comes with a double-bracketed yoke to which you can either attach mounting clamps for hanging or simply use as a floor stand. You must supply the mounting clamps. Make sure the clamps are capable of supporting the weight of this product. Use at least one mounting point per product. For the CHAUVET Professional line of mounting clamps, go to <http://www.trusst.com/products>.

Mounting Diagram

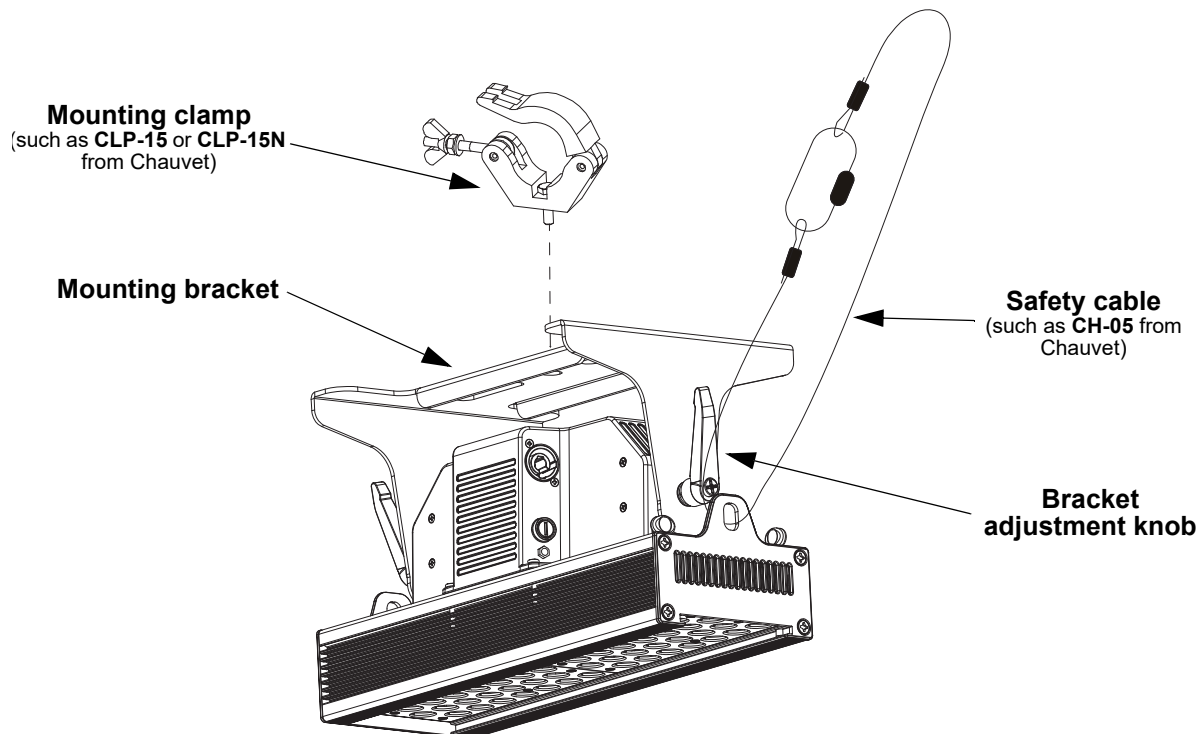

4. Operation

Control Panel Operation

Button	Function
<MENU>	Exits from the current menu or function
<ENTER>	Enables the currently displayed menu or sets the currently selected value in to the current function
<UP>	Navigates upward through the menu list or increases the numeric value when in a function
<DOWN>	Navigates downward through the menu list or decreases the numeric value when in a function

Programming

Refer to the Menu Map to understand the menu options. The menu map shows the main level and a variable number of programming levels for each option.

- To go to the desired main level, press <MENU> repeatedly until the option shows on the display. Press <ENTER> to select. This will take you to the first programming level for that option.
- To select an option or value within the current programming level, press <UP> or <DOWN> until the option shows on the display. Press <ENTER> to select. In this case, if there is another programming level, you will see that first option, or you will see the selected value.
- Press <MENU> repeatedly to exit to the previous main level.

Menu Map

Main Level	Programming Levels		Description
Protocol	DMX512		Selects the control protocol
	ArtNet		
	sACN		
Start Address	001–512*		Selects starting address (*highest channel restricted by selected personality)
Personality	1 Cell	DMX-VCW-CCT 3CH	3-channel: dimmer, virtual color wheel, color temperature
		HSV 3CH	3-channel: Hue, saturation, value
		RGB 3CH	3-channel: RGB
		RGBA 4CH	4-channel: RGBA
		RGBAL 5CH	5-channel: RGBAL
		RGB EXT 8CH	8-channel: 16-bit dimmer, RGB, virtual color wheel, color temperature, strobe
		RGBA EXT 9CH	9-channel: 16-bit dimmer, RGBA, virtual color wheel, color temperature, strobe
		RGBAL EXT 10CH	10-channel: 16-bit dimmer, RGBAL, virtual color wheel, color temperature, strobe
		RGBAL Fine 10CH	10-channel: 16-bit RGBAL
		RGBAL FULL 17CH	17-channel: 16-bit dimmer, 16-bit RGBAL, virtual color wheel, color temperature, strobe, color macros, control

Main Level	Programming Levels		Description	
Personality	2 Cell	RGB 6CH	6-channel: RGB (per cell)	
		HSV 3CH	3-channel: HSV (per cell)	
		RGBA 8CH	8-channel: RGBA (per cell)	
		RGBAL 10CH	10-channel: RGBAL (per cell)	
		RGB EXT 15CH	15-channel: 16-bit dimmer, RGB (per cell), virtual color wheel (per cell), color temperature (per cell), strobe (per cell)	
		RGBA EXT 17CH	17-channel: 16-bit dimmer, RGBA (per cell), virtual color wheel (per cell), color temperature (per cell), strobe (per cell)	
		RGBAL EXT 19CH	19-channel: 16-bit dimmer, RGBAL (per cell), virtual color wheel (per cell), color temperature (per cell), strobe (per cell)	
		RGBAL Fine 20CH	20-channel: 16-bit RGBAL (per cell)	
		RGBAL FULL 31CH	31-channel: 16-bit dimmer, 16-bit RGBAL (per cell), virtual color wheel (per cell), color temperature (per cell), strobe (per cell), color macros, control	
Virtual Color Wheel	Virtual Color Wheel	C3050 - Md Yellow	Dimmer <000–255>	Virtual Color Wheel simulates the output of each gel color. Refer to the Virtual Color Wheel Chart section for specific values.
		C3040 - Lt Yellow		
		C3240 - Amb Yellow		
		C2340 - VLt Amber		
		C2040 - Lt Amber		
		C2050 - Md Amber		
		C2060 - Dk Amber		
		C1050 - Lt Red		
		C1080 - Md Red		
		C1020 - NC Pink		
		C1030 - Md Pink		
		C1630 - Dk Pink		
		C1250 - Md Red Amber		
		C1060 - Dk Red Amber		
		C1650 - Magenta		
		C6170 - Dk Magenta		
		C6020 - Lt Lavender		
		C5030 - Lt Blue		
		C5020 - VLt Blue		
		C5430 - Lt Blue 2		
		C5070 - Blue		
		C5050 - Md Blue		
		C5060 - Dk Blue		
		C5690 - Indigo		
		C5080 - VDk Blue		
		C5081 - VDk Blue 2		
		C4370 - Yel Green		
		C4070 - Green		
		C4550 - Turquoise		
		C4560 - Aqua		
		C4570 - Blue Green		

Main Level	Programming Levels			Description	
Virtual Color Wheel (cont.)	Color Temperature	2800K	Dimmer	<000–255>	Preset white color temperatures. Emulates a tungsten lamp at the specified color temperature. Refer to the Preset Color Temperature Chart section for specific values.
		3000K			
		3200K			
		3500K			
		4000K			
		4500K			
		5000K			
		5600K			
		6000K			
	6500K				
Manual Color Mixer	Red		Combine red, green, blue, amber, and lime to make a custom color (0–100%)		
	Green				
	Blue				
	Amber				
	Lime				
Auto Show	Auto 1	Speed 1–100	Selects automatic programs and auto program speed		
	Auto 2				
	Auto 3				
	Auto 4				
	Auto 5				
	Auto 6				
	Auto 7				
	Auto 8				
	Auto 9				
	Fade				
Red Shift	On		Red shift on		
	Off		Red shift off		
Master/ Slave	Master		Master mode		
	Slave		Slave mode		
Dimmer Curve	S-Curve		S-curve		
	Linear		Linear curve		
	Square		Square law curve		
	Inverse Square		Inverse square law curve		
Dimmer Mode	Off		Linear dimmer		
	Dimmer 1		Fast dimmer curve		
	Dimmer 2		Medium dimmer curve		
	Dimmer 3		Slow dimmer curve		
White Balance	Off		Uses factory default white setting		
	Manual	Red	125–255	Sets red LED maximum value	
		Green		Sets green LED maximum value	
		Blue		Sets blue LED maximum value	
		Amber		Sets amber LED maximum value	
		Lime		Sets lime LED maximum value	

Main Level	Programming Levels		Description
LED Frequency	600Hz		Selects the PWM output frequency
	1200Hz		
	2000Hz		
	4000Hz		
	6000Hz		
	25KHz		
Display	Normal		Normal display orientation
	Inverse		Inverted display
Back Light	10S		Turns off display backlight after 10 seconds of inactivity
	30S		Turns off display backlight after 30 seconds of inactivity
	2Min		Turns off display backlight after 2 minutes of inactivity
	On		Display backlight always on
Ethernet Setting	Universe	1 (DMX)	Sets universe for Art-Net™ or sACN
		0–255 (Art-Net™)	
		1-256 (sACN)	
	IP Address	---.---.---.---	Sets IP address
Information	Fixture Hours	----H	Shows total hour product has been powered
	LED Hours	----H	Shows total LED hours
	Version	V._.-V._.	Shows installed software version
	Device ID	-----	Shows product device ID
	UID	-----	Shows product UID
Factory Setting	No		Reset to factory defaults
	Yes		

Configuration (DMX/Art-Net™/sACN)

Use control configurations to operate the product with a controller.

Control Protocol

This setting allows you to choose the protocol with which to control the Ovation B-565FC.

1. Go to the **Protocol** main level.
2. Select the desired control protocol (**DMX512**, **ArtNet**, or **sACN**).

Ethernet Setting

Ethernet protocols (Art-Net™ and sACN) require the Universe and IP address, and the [Starting Address](#) to be set.

Universe

1. Go to the **Ethernet Setting** main level.
2. Select **Universe**.
3. Set the Universe value (**0–255** for Art-Net™, or **1–256** for sACN).

IP address

1. Go to the **Ethernet Setting** main level.
1. Select **IP Address**.
2. Set the IP address (**000.000.000.000** to **255.255.255.255**)

Control Personalities

This setting allows you to choose a particular control personality.

1. Go to the **Personality** main level.
2. Select the desired number of cells to be controllable (**1 Cell** or **2 Cell**).

Select the desired personality (see table below).

Mode	1-Cell	2-Cell
DMX-VCW-CCT	3CH	N/A
RGB	3CH	6CH
HSV	3CH	6CH
RGBA	4CH	8CH
RGBAL	5CH	10CH
RGB EXT	8CH	15CH
RGBA EXT	9CH	17CH
RGBAL EXT	10CH	19CH
RGBAL Fine	10CH	20CH
RGBAL FULL	17CH	31CH



- See the [Starting Address](#) section for the highest starting address you can select for each personality.
- Make sure that the starting addresses on the various products do not overlap due to the new personality setting.

Starting Address

Each product will respond to a unique starting address from the controller. All products with the same starting address will respond in unison.

1. Go to the **Start Address** main level.
2. Select the starting address (**001–512**).

The highest recommended starting address for each DMX mode is as follows:

Personality	Address
1 Cell HSV 3CH	510
1 Cell DMX-VCW-CCT 3CH	510
1 Cell RGB 3CH	510
1 Cell RGBA 4CH	509
1 Cell RGBAL 5CH	508
1 Cell RGB EXT 8CH	505
1 Cell RGBA EXT 9CH	504
1 Cell RGBAL EXT 10CH	503
1 Cell RGBAL Fine 10CH	503
1 Cell RGBAL FULL 17CH	496
2 Cell HSV 6CH	507
2 Cell RGB 6CH	507
2 Cell RGBA 8CH	505
2 Cell RGBAL 10CH	503
2 Cell RGB EXT 15CH	498
2 Cell RGBA EXT 17CH	496
2 Cell RGBAL EXT 19CH	494
2 Cell RGBAL Fine 20CH	493
2 Cell RGBAL FULL 31CH	482

DMX Values

2-Cell Personalities

2-Cell RGBAL FULL 31CH

Channel	Function	Value	Percent/Setting
1	Dimmer	000 ⇔ 255	0–100%
2	Dimmer fine	000 ⇔ 255	0–100%
3	Red 1	000 ⇔ 255	0–100%
4	Red fine 1	000 ⇔ 255	0–100%
5	Green 1	000 ⇔ 255	0–100%
6	Green fine 1	000 ⇔ 255	0–100%
7	Blue 1	000 ⇔ 255	0–100%
8	Blue fine 1	000 ⇔ 255	0–100%
9	Amber 1	000 ⇔ 255	0–100%
10	Amber fine 1	000 ⇔ 255	0–100%
11	Lime 1	000 ⇔ 255	0–100%
12	Lime fine 1	000 ⇔ 255	0–100%
13	Virtual Color Wheel 1	000 ⇔ 255	Refer to the Virtual Color Wheel Chart for specific values
14	Color Temperature 1	000 ⇔ 255	Refer to the Preset Color Temperature Chart for specific values
15	Strobe 1	000 ⇔ 010	No function
		011 ⇔ 255	Strobe, slow to fast
16	Red 2	000 ⇔ 255	0–100%
17	Red fine 2	000 ⇔ 255	0–100%
18	Green 2	000 ⇔ 255	0–100%
19	Green fine 2	000 ⇔ 255	0–100%
20	Blue 2	000 ⇔ 255	0–100%
21	Blue fine 2	000 ⇔ 255	0–100%
22	Amber 2	000 ⇔ 255	0–100%
23	Amber fine 2	000 ⇔ 255	0–100%
24	Lime 1	000 ⇔ 255	0–100%
25	Lime fine 1	000 ⇔ 255	0–100%
26	Virtual Color Wheel 1	000 ⇔ 255	Refer to the Virtual Color Wheel Chart for specific values
27	Color Temperature 1	000 ⇔ 255	Refer to the Preset Color Temperature Chart for specific values
28	Strobe 1	000 ⇔ 010	No function
		011 ⇔ 255	Strobe, slow to fast
29	Strobe all	000 ⇔ 010	No function
		011 ⇔ 255	Strobe, slow to fast
30	Color macros	000 ⇔ 015	No function
		016 ⇔ 255	Color macros

Channel	Function	Value	Percent/Setting
31	Control (hold for 3 seconds)	000 ⇔ 007	No function
		008 ⇔ 015	Dimmer reset
		016 ⇔ 023	Red shift on
		024 ⇔ 031	Red shift off
		032 ⇔ 039	S-curve dimmer
		040 ⇔ 047	Linear dimmer
		048 ⇔ 055	Square dimmer curve
		056 ⇔ 063	Inverse square dimmer curve
		064 ⇔ 071	Dimmer speed mode OFF
		072 ⇔ 079	Dimmer speed 1 (fastest)
		080 ⇔ 087	Dimmer speed 2
		088 ⇔ 095	Dimmer speed 3 (slowest)
		096 ⇔ 255	Reserved for future use

2-Cell RGBAL Fine 20CH

Channel	Function	Value	Percent/Setting
1	Red 1	000 ⇔ 255	0–100%
2	Red fine 1	000 ⇔ 255	0–100%
3	Green 1	000 ⇔ 255	0–100%
4	Green fine 1	000 ⇔ 255	0–100%
5	Blue 1	000 ⇔ 255	0–100%
6	Blue fine 1	000 ⇔ 255	0–100%
7	Amber 1	000 ⇔ 255	0–100%
8	Amber fine 1	000 ⇔ 255	0–100%
9	Lime 1	000 ⇔ 255	0–100%
10	Lime fine 1	000 ⇔ 255	0–100%
11	Red 2	000 ⇔ 255	0–100%
12	Red fine 2	000 ⇔ 255	0–100%
13	Green 2	000 ⇔ 255	0–100%
14	Green fine 2	000 ⇔ 255	0–100%
15	Blue 2	000 ⇔ 255	0–100%
16	Blue fine 2	000 ⇔ 255	0–100%
17	Amber 2	000 ⇔ 255	0–100%
18	Amber fine 2	000 ⇔ 255	0–100%
19	Lime 2	000 ⇔ 255	0–100%
20	Lime fine 2	000 ⇔ 255	0–100%

2-Cell RGBAL EXT 19CH

Channel	Function	Value	Percent/Setting
1	Dimmer	000 ⇔ 255	0–100%
2	Dimmer fine	000 ⇔ 255	0–100%
3	Red 1	000 ⇔ 255	0–100%
4	Green 1	000 ⇔ 255	0–100%
5	Blue 1	000 ⇔ 255	0–100%
6	Amber 1	000 ⇔ 255	0–100%
7	Lime 1	000 ⇔ 255	0–100%

Channel	Function	Value	Percent/Setting
8	Virtual Color Wheel 1	000 ⇔ 255	Refer to the Virtual Color Wheel Chart for specific values
9	Color Temperature 1	000 ⇔ 255	Refer to the Preset Color Temperature Chart for specific values
10	Strobe 1	000 ⇔ 010	No function
		011 ⇔ 255	Strobe, slow to fast
11	Red 2	000 ⇔ 255	0–100%
12	Green 2	000 ⇔ 255	0–100%
13	Blue 2	000 ⇔ 255	0–100%
14	Amber 2	000 ⇔ 255	0–100%
15	Lime 2	000 ⇔ 255	0–100%
16	Virtual Color Wheel 2	000 ⇔ 255	Refer to the Virtual Color Wheel Chart for specific values
17	Color Temperature 2	000 ⇔ 255	Refer to the Preset Color Temperature Chart for specific values
18	Strobe 2	000 ⇔ 010	No function
		011 ⇔ 255	Strobe, slow to fast
19	Strobe all	000 ⇔ 010	No function
		011 ⇔ 255	Strobe, slow to fast

2-Cell RGBA EXT 17CH

Channel	Function	Value	Percent/Setting
1	Dimmer	000 ⇔ 255	0–100%
2	Dimmer fine	000 ⇔ 255	0–100%
3	Red 1	000 ⇔ 255	0–100%
4	Green 1	000 ⇔ 255	0–100%
5	Blue 1	000 ⇔ 255	0–100%
6	Amber 1	000 ⇔ 255	0–100%
7	Virtual Color Wheel 1	000 ⇔ 255	Refer to the Virtual Color Wheel Chart for specific values
8	Color Temperature 1	000 ⇔ 255	Refer to the Preset Color Temperature Chart for specific values
9	Strobe 1	000 ⇔ 010	No function
		011 ⇔ 255	Strobe, slow to fast
10	Red 2	000 ⇔ 255	0–100%
11	Green 2	000 ⇔ 255	0–100%
12	Blue 2	000 ⇔ 255	0–100%
13	Amber 2	000 ⇔ 255	0–100%
14	Virtual Color Wheel 2	000 ⇔ 255	Refer to the Virtual Color Wheel Chart for specific values
15	Color Temperature 2	000 ⇔ 255	Refer to the Preset Color Temperature Chart for specific values
16	Strobe 2	000 ⇔ 010	No function
		011 ⇔ 255	Strobe, slow to fast
17	Strobe all	000 ⇔ 010	No function
		011 ⇔ 255	Strobe, slow to fast

2-Cell RGB EXT 15CH

Channel	Function	Value	Percent/Setting
1	Dimmer	000 ⇔ 255	0–100%
2	Dimmer Fine	000 ⇔ 255	0–100%
3	Red 1	000 ⇔ 255	0–100%
4	Green 1	000 ⇔ 255	0–100%
5	Blue 1	000 ⇔ 255	0–100%

Channel	Function	Value	Percent/Setting
6	Virtual Color Wheel 1	000 ⇔ 255	Refer to the Virtual Color Wheel Chart for specific values
7	Color Temperature 1	000 ⇔ 255	Refer to the Preset Color Temperature Chart for specific values
8	Strobe 1	000 ⇔ 010	No function
		011 ⇔ 255	Strobe, slow to fast
9	Red 2	000 ⇔ 255	0–100%
10	Green 2	000 ⇔ 255	0–100%
11	Blue 2	000 ⇔ 255	0–100%
12	Virtual Color Wheel 2	000 ⇔ 255	Refer to the Virtual Color Wheel Chart for specific values
13	Color Temperature 2	000 ⇔ 255	Refer to the Preset Color Temperature Chart for specific values
14	Strobe 2	000 ⇔ 010	No function
		011 ⇔ 255	Strobe, slow to fast
15	Strobe all	000 ⇔ 010	No function
		011 ⇔ 255	Strobe, slow to fast

2-Cell RGBAL 10CH

Channel	Function	Value	Percent/Setting
1	Red 1	000 ⇔ 255	0–100%
2	Green 1	000 ⇔ 255	0–100%
3	Blue 1	000 ⇔ 255	0–100%
4	Amber 1	000 ⇔ 255	0–100%
5	Lime 1	000 ⇔ 255	0–100%
6	Red 2	000 ⇔ 255	0–100%
7	Green 2	000 ⇔ 255	0–100%
8	Blue 2	000 ⇔ 255	0–100%
9	Amber 2	000 ⇔ 255	0–100%
10	Lime 2	000 ⇔ 255	0–100%

2-Cell RGBA 8CH

Channel	Function	Value	Percent/Setting
1	Red 1	000 ⇔ 255	0–100%
2	Green 1	000 ⇔ 255	0–100%
3	Blue 1	000 ⇔ 255	0–100%
4	Amber 1	000 ⇔ 255	0–100%
5	Red 2	000 ⇔ 255	0–100%
6	Green 2	000 ⇔ 255	0–100%
7	Blue 2	000 ⇔ 255	0–100%
8	Amber 2	000 ⇔ 255	0–100%

2-Cell RGB 6CH

Channel	Function	Value	Percent/Setting
1	Red 1	000 ⇔ 255	0–100%
2	Green 1	000 ⇔ 255	0–100%
3	Blue 1	000 ⇔ 255	0–100%
4	Red 2	000 ⇔ 255	0–100%
5	Green 2	000 ⇔ 255	0–100%
6	Blue 2	000 ⇔ 255	0–100%

2-Cell HSV 6CH

Channel	Function	Value	Percent/Setting
1	Hue 1	000 ⇔ 255	0–100%
2	Saturation 1	000 ⇔ 255	0–100%
3	Value 1	000 ⇔ 255	0–100%
4	Hue 2	000 ⇔ 255	0–100%
5	Saturation 2	000 ⇔ 255	0–100%
6	Value 2	000 ⇔ 255	0–100%

1-Cell Personalities

1-Cell RGBAL FULL 17CH

Channel	Function	Value	Percent/Setting
1	Dimmer	000 ⇔ 255	0–100%
2	Dimmer fine	000 ⇔ 255	0–100%
3	Red	000 ⇔ 255	0–100%
4	Red fine	000 ⇔ 255	0–100%
5	Green	000 ⇔ 255	0–100%
6	Green fine	000 ⇔ 255	0–100%
7	Blue	000 ⇔ 255	0–100%
8	Blue fine	000 ⇔ 255	0–100%
9	Amber	000 ⇔ 255	0–100%
10	Amber fine	000 ⇔ 255	0–100%
11	Lime	000 ⇔ 255	0–100%
12	Lime fine	000 ⇔ 255	0–100%
13	Virtual Color Wheel	000 ⇔ 255	Refer to the Virtual Color Wheel Chart for specific values
14	Color Temperature	000 ⇔ 255	Refer to the Preset Color Temperature Chart for specific values
15	Strobe	000 ⇔ 010	No function
		011 ⇔ 255	Strobe, slow to fast
16	Color macros	000 ⇔ 015	No function
		016 ⇔ 255	Color macros
17	Control (hold for 3 seconds)	000 ⇔ 007	No function
		008 ⇔ 015	Dimmer reset
		016 ⇔ 023	Red shift on
		024 ⇔ 031	Red shift off
		032 ⇔ 039	S-curve dimmer
		040 ⇔ 047	Linear dimmer
		048 ⇔ 055	Square dimmer curve
		056 ⇔ 063	Inverse square dimmer curve
		064 ⇔ 071	Dimmer speed mode OFF
		072 ⇔ 079	Dimmer speed 1 (fastest)
		080 ⇔ 087	Dimmer speed 2
		088 ⇔ 095	Dimmer speed 3 (slowest)
		096 ⇔ 255	Reserved for future use

OPERATION

1-Cell RGBAL Fine 10CH

Channel	Function	Value	Percent/Setting
1	Red	000 ⇔ 255	0–100%
2	Red fine	000 ⇔ 255	0–100%
3	Green	000 ⇔ 255	0–100%
4	Green fine	000 ⇔ 255	0–100%
5	Blue	000 ⇔ 255	0–100%
6	Blue fine	000 ⇔ 255	0–100%
7	Amber	000 ⇔ 255	0–100%
8	Amber fine	000 ⇔ 255	0–100%
9	Lime	000 ⇔ 255	0–100%
10	Lime fine	000 ⇔ 255	0–100%

1-Cell RGBAL EXT 10CH

Channel	Function	Value	Percent/Setting
1	Dimmer	000 ⇔ 255	0–100%
2	Dimmer fine	000 ⇔ 255	0–100%
3	Red	000 ⇔ 255	0–100%
4	Green	000 ⇔ 255	0–100%
5	Blue	000 ⇔ 255	0–100%
6	Amber	000 ⇔ 255	0–100%
7	Lime	000 ⇔ 255	0–100%
8	Virtual Color Wheel	000 ⇔ 255	Refer to the Virtual Color Wheel Chart for specific values
9	Color Temperature	000 ⇔ 255	Refer to the Preset Color Temperature Chart for specific values
10	Strobe	000 ⇔ 010	No function
		011 ⇔ 255	Strobe, slow to fast

1-Cell RGBA EXT 9CH

Channel	Function	Value	Percent/Setting
1	Dimmer	000 ⇔ 255	0–100%
2	Dimmer fine	000 ⇔ 255	0–100%
3	Red	000 ⇔ 255	0–100%
4	Green	000 ⇔ 255	0–100%
5	Blue	000 ⇔ 255	0–100%
6	Amber	000 ⇔ 255	0–100%
7	Virtual Color Wheel	000 ⇔ 255	Refer to the Virtual Color Wheel Chart for specific values
8	Color Temperature	000 ⇔ 255	Refer to the Preset Color Temperature Chart for specific values
9	Strobe	000 ⇔ 010	No function
		011 ⇔ 255	Strobe, slow to fast

1-Cell RGB EXT 8CH

Channel	Function	Value	Percent/Setting
1	Dimmer	000 ⇔ 255	0–100%
2	Dimmer fine	000 ⇔ 255	0–100%
3	Red	000 ⇔ 255	0–100%
4	Green	000 ⇔ 255	0–100%
5	Blue	000 ⇔ 255	0–100%

Channel	Function	Value	Percent/Setting
6	Virtual Color Wheel	000 ⇔ 255	Refer to the Virtual Color Wheel Chart for specific values
7	Color Temperature	000 ⇔ 255	Refer to the Preset Color Temperature Chart for specific values
8	Strobe	000 ⇔ 010	No function
		011 ⇔ 255	Strobe, slow to fast

1-Cell RGBAL 5CH

Channel	Function	Value	Percent/Setting
1	Red	000 ⇔ 255	0–100%
2	Green	000 ⇔ 255	0–100%
3	Blue	000 ⇔ 255	0–100%
4	Amber	000 ⇔ 255	0–100%
5	Lime	000 ⇔ 255	0–100%

1-Cell RGBA 4CH

Channel	Function	Value	Percent/Setting
1	Red	000 ⇔ 255	0–100%
2	Green	000 ⇔ 255	0–100%
3	Blue	000 ⇔ 255	0–100%
4	Amber	000 ⇔ 255	0–100%

1-Cell RGB 3CH

Channel	Function	Value	Percent/Setting
1	Red	000 ⇔ 255	0–100%
2	Green	000 ⇔ 255	0–100%
3	Blue	000 ⇔ 255	0–100%

1-Cell DMX-VCW-CCT 3CH

Channel	Function	Value	Percent/Setting
1	Dimmer	000 ⇔ 255	0–100%
2	Virtual Color Wheel	000 ⇔ 255	Refer to the Virtual Color Wheel Chart for specific values
3	Color Temperature	000 ⇔ 255	Refer to the Preset Color Temperature Chart for specific values

1-Cell HSV 3CH

Channel	Function	Value	Percent/Setting
1	Hue	000 ⇔ 255	0–100%
2	Saturation	000 ⇔ 255	0–100%
3	Value	000 ⇔ 255	0–100%

Virtual Color Wheel

The Ovation B-565FC includes a feature called the Virtual Color Wheel (VCW). This feature is available as a standalone control mode for manual use and also as a control channel in select DMX personalities. More than 30 pre-mixed colors, custom blended by our engineers, are available to call up for easier programming. The DMX values used to mix these colors are provided below. You may adjust the overall intensity of the Ovation fixture in order to more closely replicate colors you are familiar with. A chart is available on our website www.chauvetprofessional.com to compare our pre-mixed colors with popular gel colors. This chart is for comparison purposes only and is not a representation that our pre-mixed colors match any of the gel colors listed.

Virtual Color Wheel Chart

DMX Channel Value	Display Readout	Red Value	Green Value	Blue Value	Amber Value	Lime Value
000 ⇄ 005	--	000	000	000	000	000
006 ⇄ 013	C3050 - Md Yellow	150	125	002	255	043
014 ⇄ 021	C3040 - Lt Yellow	235	108	005	255	076
022 ⇄ 028	C3240 - Amb Yellow	171	036	000	120	255
029 ⇄ 035	C2340 - VLt Amber	255	015	017	255	170
036 ⇄ 043	C2040 - Lt Amber	255	000	010	255	143
044 ⇄ 051	C2050 - Md Amber	255	000	003	255	075
052 ⇄ 059	C2060 - Dk Amber	188	000	002	255	044
060 ⇄ 067	C1050 - Lt Red	255	000	002	021	002
068 ⇄ 075	C1080 - Md Red	255	000	002	000	000
076 ⇄ 083	C1020 - NC Pink	255	130	025	255	027
084 ⇄ 091	C1030 - Md Pink	255	013	041	235	182
092 ⇄ 099	C1630 - Dk Pink	255	015	027	030	255
100 ⇄ 107	C1250 - Md Red Amber	255	000	004	115	009
108 ⇄ 115	C1060 - Dk Red Amber	255	000	004	011	008
116 ⇄ 121	C1650 - Magenta	255	000	022	081	039
122 ⇄ 130	C6170 - Dk Magenta	160	000	025	000	004
131 ⇄ 138	C6020 - Lt Lavender	255	162	043	255	140
139 ⇄ 146	C5030 - Lt Blue	012	255	070	076	115
147 ⇄ 154	C5020 - VLt Blue	030	187	085	215	255
155 ⇄ 162	C5430 - Lt Blue 2	004	255	062	093	049
163 ⇄ 170	C5070 - Blue	005	255	190	003	012
171 ⇄ 178	C5050 - Md Blue	008	250	145	005	088
179 ⇄ 186	C5060 - Dk Blue	005	209	255	015	074
187 ⇄ 194	C5690 - Indigo	005	000	200	013	003
195 ⇄ 202	C5080 - VDk Blue	007	112	255	005	007
203 ⇄ 210	C5081 - VDk Blue 2	004	108	255	003	004
211 ⇄ 218	C4370 - Yel Green	004	255	000	005	003
219 ⇄ 226	C4070 - Green	027	255	006	000	020
227 ⇄ 234	C4550 - Turquoise	007	255	021	070	076
235 ⇄ 242	C4560 - Aqua	007	255	031	085	115
243 ⇄ 250	C4570 - Blue Green	002	255	017	002	020
251 ⇄ 255	--	000	000	000	000	000



Note: The colors above are simulated renditions of the color output produced as compared with other similar incandescent products. Chauvet makes no guarantee of the color output accuracy.

Preset Color Temperature Chart

DMX Channel Value	Display Readout	Red Value	Green Value	Blue Value	Amber Value	Lime Value
000 ⇄ 005	--	000	000	000	000	000
006 ⇄ 025	2800K	237	120	036	255	255
026 ⇄ 050	3000K	220	128	050	255	255
051 ⇄ 075	3200K	176	128	057	255	255
076 ⇄ 100	3500K	154	128	080	255	255
101 ⇄ 125	4000K	128	128	112	255	255
126 ⇄ 150	4500K	108	128	133	255	255
151 ⇄ 175	5000K	097	128	152	255	255
176 ⇄ 200	5600K	087	128	170	255	255
201 ⇄ 225	6000K	075	128	177	255	255
226 ⇄ 250	6500K	066	128	187	255	255
251 ⇄ 255	--	000	000	000	000	000



Note: The color temperatures above are simulated renditions of the color output produced as compared with a tungsten lamp at the specified color temperature. Chauvet makes no guarantee of the color output accuracy.

Configuration (Standalone)

Use standalone configuration to operate the product without a DMX controller.

Static Mode

The Static mode allows for an unchanging color without a DMX controller.

Virtual Color Wheel

1. Go to the **Virtual Color Wheel** main level.
2. Select **Virtual Color Wheel**.
3. Select the desired gel color (see [Virtual Color Wheel Chart](#)).
4. Select the desired output level (<000–255>).

Color Temperature

1. Go to the **Virtual Color Wheel** main level.
2. Select **Color Temperature**.
3. Select the desired color temperature (see [Preset Color Temperature Chart](#)).
4. Select the desired output level (<000–255>).

Manual Color Mixer

1. Go to the **Virtual Color Wheel** main level.
2. Select **Manual Color Mixer**.
3. Select the color to edit (**Red, Green, Blue, Amber, or Lime**).
4. Select the desired output level for that color (<000–255>).
5. Repeat steps 3 and 4 until product outputs as desired.

Auto Programs

Auto programs allow for dynamic blinder effects without a DMX controller.

1. Go to the **Auto Show** main level
2. Select the desired auto program (**Auto 1–9** or **Fade**).
3. Select the desired speed (**1–100**).



The auto programs cannot be edited.

Red Shift

This function causes the color temperature of the LEDs to imitate the appearance of a lamp when dimming.

1. Go to the **Red Shift** main level.
2. Select from **On** or **Off**.

Master/Slave

The Master/Slave mode allows a group of Ovation B-565FC products (the slaves) to simultaneously duplicate the output of another Ovation B-565FC (the master) without a DMX controller.

To set each of the slaves:

1. Go to the **Master/Slave** main level
2. Select **Slave**.

To set the master:

1. Go to the **Master/Slave** main level
2. Select **Master**.
3. Select an auto program, as explained in Auto Programs, or a static setting.



- **The master is the one that runs a program whether in Auto or Static mode.**
- **Do not connect a DMX controller to the products configured for Master/Slave operation. The DMX controller may interfere with signals from the master.**
- **The master should be the first product in the daisy chain.**

Dimmer Curve

This setting determines the curve on which the output dims when you modify the output value.

1. Go to the **Dimmer Curve** main level.
2. Select a dimmer curve (**S-Curve**, **Linear**, **Square**, or **Inverse Square**).



S-Curve: The output follows an S-shaped curve.

Linear: The output is proportional (linear) to the dimmer channel value.

Square: The output follows a square-law curve.

Inverse Square: The output follows an inverse square-law curve.

Dimmer Profiles

This setting determines how fast the output of the Ovation B-565FC changes when you modify the output value. This setting provides four different options to simulate the dimming curve of an incandescent lighting product.

1. Go to the **Dimmer Mode** main level.
2. Select a dimmer curve (**Off**, **Dimmer 1**, **Dimmer 2**, or **Dimmer 3**).



Off: The output is proportional (linear) to the dimmer channel value.

Dimmer 1-3: The output follows the dimmer value based on the corresponding dimmer curve, DIM1 being the fastest.

White Balance

This setting determines the maximum output values for each color, which affects the appearance of a full output white.

1. Go to the White Balance main level.
2. Select **Off** (the product will use a default setting) or **Manual**.
3. For **Manual** mode, select the color value to edit (**Red**, **Green**, **Blue**, **Amber**, or **Lime**).
4. Set the maximum value for the selected color (**000–255**).
5. Repeat steps 3 and 4 until the product outputs as desired.

LED Frequency

This option changes the Pulse Width Modulation (PWM) frequency of the LEDs on the Ovation B-565FC.

1. Go to the **LED Frequency** main level.
2. Select PWM Frequency (**600Hz**, **1200Hz**, **2000Hz**, **4000Hz**, **6000Hz**, or **25kHz**).

Display Orientation

This setting allows for selection of the display orientation.

1. Go to the **Display** main menu,
2. Select **Normal** (upright display) or **Inverse** (inverted display).

Back Light

This setting allows for selection of the amount of time the backlight on the Ovation B-565FC's display stays on after the last button is pressed on the control panel.

1. Go to the **Back Light** main level.
2. Select **10S** (10 seconds), **30S** (20 seconds), **2Min** (2 minutes), or **On** (backlight remains on).

System Information

This option displays the total number of hours the product has run, the installed software version, and the product's UID.

1. Go to the **Information** main level.
2. Select **Fixture Hours**, **LED Hours**, **Version**, **Device ID**, or **UID**.

Factory Reset

This option restores the Ovation B-565FC to factory default settings.

1. Go to the **Factory Setting** main level.
2. Select **No** or **Yes**.

Web Server

The Ovation B-565FC Web Server can be accessed by any computer on the same network as the product. It allows network access to system information, settings such as control protocol and starting address, color output testing, and the ability to change the Web Server password.

1. Connect the product to a Windows computer with a network cable.
2. On the computer, set the IP address of the new network to have the same first 3 digits as the IP address of the product (See [IP address](#)).
3. Enter the IP address of the product into the URL bar of a web browser on the computer.
4. Enter both the User Name and Password as **admin** to log in.

Home

The Web Server Home page displays the details of all available control protocols and the technical specifications for the Ovation B-565FC.

Settings

The Web Server Settings page provides options for control. From the drop-down menus, the Protocol, Universe, IP Address, Start Address, Personality, Dimmer Mode, and PWM Frequency can all be edited. Click **Save Settings** to send the new configuration to the product.

Output

On the Web Server Output page, an output test of the product's LEDs can be performed, by either editing the values of each LED manually (by typing the number or moving the fader), or by selecting a sample color. The page will show the current output color on the bottom left. To stop the output test, click **Click to Stop**.

Security

The Web Server Security page gives the option to change the password to the connected product's web server. Enter the old password (**admin**, by default) and the new password twice, then click **Save Settings** to change the password.

5. TECHNICAL INFORMATION

Product Maintenance

To maintain optimum performance and minimize wear, clean this product frequently. Usage and environment are contributing factors in determining the cleaning frequency.

Clean this product at least twice a month. Dust build-up reduces light output performance and can cause overheating. This can lead to reduced light source life and increased mechanical wear.

To clean the product:

1. Unplug the product from power.
2. Wait until the product is at room temperature.
3. Use a vacuum (or dry compressed air) and a soft brush to remove dust collected on the external vents.
4. Clean all transparent surfaces with a mild soap solution, ammonia-free glass cleaner, or isopropyl alcohol.
5. Apply the solution directly to a soft, lint-free cotton cloth or a lens-cleaning tissue.
6. Softly drag any dirt or grime to the outside of the transparent surface.
7. Gently polish the transparent surfaces until they are free of haze and lint.



Always dry the transparent surfaces carefully after cleaning them.

6. Technical Specifications

Dimensions and Weight

Length	Width	Height	Weight
13.9 in (355 mm)	7.48 in (190 mm)	8.14 in (207 mm)	11.6 lb (5.3 kg)

Note: Dimensions in inches rounded to the nearest decimal digit.

Power

Power Supply Type	Range	Voltage Selection
Switching (internal)	100 to 240 VAC, 50/60 Hz	Auto-ranging

Parameter	120 V, 60 Hz	208 V, 60 Hz	230 V, 50 Hz
Consumption	125 W	120 W	119 W
Operating current	1.04 A	0.61 A	0.51 A
Power-linking current (products)	13.6A (13 products)	13.6A (22 products)	13.6 A (23 products)
Fuse	T 2 A, 250 V	T 2 A, 250 V	T 2 A, 250 V

Power I/O	U.S./Worldwide	UK/Europe
Power input connector	Neutrik® powerCON® A	Neutrik® powerCON® A
Power output connector	Neutrik® powerCON® B	Neutrik® powerCON® B
Power cord plug	Edison (U.S.)	Local plug

Light Source

Type	Power	Lifespan
LED	3 W	50,000 hours

Color	Quantity	Current
Red	12	650 mA
Green	12	650 mA
Blue	12	650 mA
Amber	8	650 mA
Lime	12	650 mA

Photometrics

Parameter	Horizontal Value	Horizontal Value w/ Filter	Vertical Value	Vertical Value w/ Filter
Beam angle	19°	36°	20°	20°
Field angle	37°	66°	37°	40°
Illuminance @ 5 m	1,637 lux	470 lux		

Thermal

Maximum External Temperature	Cooling System
113 °F (45 °C)	Convection

DMX

I/O Connector	Channel Range
3- and 5-pin XLR, Amphenol etherCON®	1 Cell: 3, 3, 3, 4, 5, 8, 9, 10, 10, 17 2 Cell: 6, 8, 10, 15, 17, 19, 20, 31

Ordering

Product Name	Item Name	Item Code	UPC Number
Ovation B-565FC	OVATIONB565FC	03031236	781462215842



UL 1573
CSA C22.2 No. 166
E113093

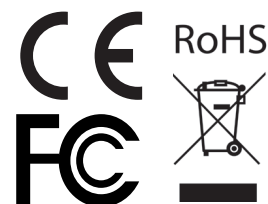

Returns

Returns

Send the product prepaid, in the original box, and with the original packing and accessories. Chauvet will not issue call tags.

Call Chauvet and request a Return Merchandise Authorization (RMA) number before shipping the product. Be prepared to provide the model number, serial number, and a brief description of the cause(s) for the return.

Clearly label the package with an RMA number. Chauvet will refuse any product returned without an RMA number.



Write the RMA number on a properly affixed label. DO NOT write the RMA number directly on the box.

Once you have the RMA number, provide the following information on a piece of paper and place it inside the box:

- Your name
- Your address
- Your phone number
- RMA number
- A brief description of the problem

Be sure to pack the product properly. Any shipping damage resulting from inadequate packaging will be your responsibility. FedEx packing or double-boxing are recommended.



Chauvet reserves the right to use its own discretion to repair or replace returned product(s).

Contact Us

General Information	Technical Support
Chauvet World Headquarters	
Address: 5200 NW 108th Ave. Sunrise, FL 33351 Voice: (954) 577-4455 Fax: (954) 929-5560 Toll Free: (800) 762-1084	Voice: (844) 393-7575 Fax: (954) 756-8015 Email: chauvetcs@chauvetlighting.com Website: www.chauvetprofessional.com
Chauvet Europe Ltd	
Address: Unit 1C Brookhill Road Industrial Estate Pinxton, Nottingham, UK NG16 6NT Voice: +44 (0) 1773 511115 Fax: +44 (0) 1773 511110	Email: UKtech@chauvetlighting.eu Website: www.chauvetprofessional.eu
Chauvet Europe BVBA	
Address: Stokstraat 18 9770 Kruishoutem Belgium Voice: +32 9 388 93 97	Email: BNLtech@chauvetlighting.eu Website: www.chauvetprofessional.eu
Chauvet France	
Address: 3, Rue Ampère 91380 Chilly-Mazarin France Voice: +33 1 78 85 33 59	Email: FRtech@chauvetlighting.fr Website: www.chauvetprofessional.eu
Chauvet Germany	
Address: Bruno-Bürgel-Str. 11 28759 Bremen Germany Voice: +49 421 62 60 20	Email: DEtech@chauvetlighting.de Website: www.chauvetprofessional.eu
Chauvet Mexico	
Address: Av. de las Partidas 34 - 3B (Entrance by Calle 2) Zona Industrial Lerma Lerma, Edo. de México, CP 52000 Voice: +52 (728) 690-2010	Email: servicio@chauvet.com.mx Website: www.chauvetprofessional.mx

Visit the applicable website above to verify our contact information and instructions to request support. Outside the U.S., U.K., Ireland, Benelux, France, Germany, or Mexico, contact the dealer of record.