

# ROGUE

## User Manual



<b>Edition Notes</b>	The Rogue R1 FX-B User Manual Rev. 11 covers the description, safety precautions, installation, programming, operation, and maintenance of the Rogue R1 FX-B. Chauvet released this edition of the Rogue R1 FX-B User Manual in August 2022.
<b>Trademarks</b>	Chauvet, Chauvet Professional, the Chauvet logo, and Rogue are registered trademarks or trademarks of Chauvet & Sons, LLC (d/b/a Chauvet and Chauvet Lighting) in the United States and other countries. Other company and product names and logos referred to herein may be trademarks of their respective companies.
<b>Copyright Notice</b>	The works of authorship contained in this manual, including, but not limited to, all design, text and images are owned by Chauvet. © <b>Copyright 2022 Chauvet &amp; Sons, LLC. All rights reserved.</b> Electronically published by Chauvet in the United States of America.
<b>Manual Use</b>	Chauvet authorizes its customers to download and print this manual for professional information purposes only. Chauvet expressly prohibits the usage, copy, storage, distribution, modification, or printing of this manual or its content for any other purpose without written consent from Chauvet.
<b>Document Printing</b>	For better results, print this document in color, on letter size paper (8.5 x 11 in), double-sided. If using A4 paper (210 x 297 mm), configure your printer to scale the content accordingly.
<b>Intended Audience</b>	Any person in charge of installing, operating, and/or maintaining this product should completely read through the guide that shipped with the product, as well as this manual, before installing, operating, or maintaining this product.
<b>Disclaimer</b>	Chauvet believes that the information contained in this manual is accurate in all respects. However, Chauvet assumes no responsibility and specifically disclaims any and all liability to any party for any loss, damage or disruption caused by any errors or omissions in this document, whether such errors or omissions result from negligence, accident or any other cause. Chauvet reserves the right to revise the content of this document without any obligation to notify any person or company of such revision, however, Chauvet has no obligation to make, and does not commit to make, any such revisions.
<b>Document Revision</b>	The Rogue R1 FX-B User Manual is the latest edition of this manual. Go to <a href="http://www.chauvetprofessional.com">www.chauvetprofessional.com</a> for the latest version.

## Table of Contents

<b>1. Before You Begin</b> .....	<b>1</b>
What Is Included .....	1
Claims.....	1
Manual Conventions .....	1
Symbols .....	1
Safety Notes .....	2
Expected LED Lifespan .....	2
<b>2. Introduction</b> .....	<b>3</b>
Description .....	3
Features .....	3
Overview .....	3
Dimensions .....	4
<b>3. Setup</b> .....	<b>5</b>
AC Power .....	5
AC Plug .....	5
Fuse Replacement .....	5
Power Linking .....	5
Mounting .....	6
Orientation.....	6
Signal Connections .....	7
Art-Net™ Connection .....	7
sACN Connection.....	7
Kling-Net Connection .....	7
<b>4. Operation</b> .....	<b>8</b>
Touchscreen Control Panel .....	8
Control Panel Description.....	8
Battery Powered Display.....	8
Menu Map .....	8
Protocol Configuration .....	13
Single Control.....	13
Single Control Protocol .....	13
Single Control Personality.....	13
Single Control Start Address.....	13
Single Control Universe .....	13
Dual Control.....	14
Dual Control Movement .....	14
Dual Control Movement Protocol .....	14
Dual Control Movement Personality .....	14
Dual Control Movement Start Address .....	14
Dual Control Movement Universe .....	14
Dual Control Pixel .....	15
Dual Control Pixel Protocol .....	15
Dual Control Pixel Personality .....	15
Dual Control Pixel Start Address .....	15
Dual Control Pixel Universe .....	15
Zones for Pixel control .....	16
DMX Values .....	16
Single Control Values.....	16
Tour 2 (52-channel) .....	16
Tour (47-channel) .....	22
Advanced Mode (47-channel).....	28
Standard Mode (25-channel) .....	34
Basic Mode (18-channel) .....	40



Dual Control Movement Values .....	45
Advanced Movement Mode (23-channel) .....	45
Standard Movement Mode (17-channel).....	48
Basic Movement Mode (10-channel) .....	51
Dual Control Pixel Values.....	53
RGBW Mode (20-channel).....	53
RGB Mode (15-channel) .....	53
Operating Settings Configuration .....	54
Home Screen .....	54
Test Mode.....	54
Auto Test.....	54
Manual Test .....	54
Setup .....	54
Network Settings .....	55
IP Mode.....	55
IP Address .....	55
Subnet Mask .....	55
Pan/Tilt Orientation .....	56
Display Orientation.....	56
Pan/Tilt Angle Range .....	56
Blackout on Pan/Tilt Movement .....	56
Touchscreen Calibration .....	56
Touchscreen Lock.....	56
Lock Screen .....	57
Backlight Timer .....	57
Loss of Data.....	57
Color Mixing Mode .....	57
Dimmer Curve.....	57
Dimmer Speed.....	58
PWM Option.....	58
Color Balance .....	58
Preset Select.....	58
Preset Sync.....	59
Reset Functions .....	59
Factory Reset.....	59
System Information .....	59
Offset Mode .....	60
<b>5. Firmware Update.....</b>	<b>61</b>
<b>6. Technical Information.....</b>	<b>64</b>
Product Maintenance .....	64
<b>7. Technical Specifications .....</b>	<b>65</b>
<b>Returns .....</b>	<b>66</b>
<b>Contact Us.....</b>	<b>67</b>

# 1. BEFORE YOU BEGIN

- What Is Included**
- Rogue R1 FX-B
  - Neutrik® powerCON® power cord
  - 2 Omega brackets with mounting hardware
  - Quick Reference Guide

**Claims** Carefully unpack the product immediately and check the box to make sure all the parts are in the package and are in good condition. If the box or the contents (the product and included accessories) appear damaged from shipping or show signs of mishandling, notify the carrier immediately, not Chauvet. Failure to report damage to the carrier immediately may invalidate your claim. In addition, keep the box and contents for inspection. For other issues, such as missing components or parts, damage not related to shipping, or concealed damage, file a claim with Chauvet within 7 days of delivery.

<b>Manual Conventions</b>	<b>Convention</b>	<b>Meaning</b>
	<b>1–512</b>	A range of values in the text
	<b>50/60</b>	A set of mutually exclusive values in the text
	<b>&lt;SET&gt;</b>	A button on the product’s control panel
	<b>Settings</b>	A product function or a menu option
	<b>ON</b>	A unique value to be entered or selected in a menu

<b>Symbols</b>	<b>Symbols</b>	<b>Meaning</b>
		Critical installation, configuration, or operation information. Failure to comply with this information may cause the product not to work, damage third-party equipment, or cause harm to the operator.
		Important installation or configuration information. Failure to comply with this information may keep the product from working.
		Useful information.

 The term “DMX” used throughout this manual refers to the USITT DMX512-A digital data transmission protocol.

### Safety Notes

Read all the following Safety Notes before working with this product. These notes include important information about the installation, usage, and maintenance of this product.



**This product contains no user-serviceable parts. Any reference to servicing in this User Manual will only apply to properly trained Chauvet certified technicians. Do not open the housing or attempt any repairs.**



**All applicable local codes and regulations apply to proper installation of this product.**

#### Personal Safety

- Avoid direct eye exposure to the light source while the product is on.
- Always disconnect this product from its power source before servicing.
- Always connect this product to a grounded circuit to avoid the risk of electrocution.
- Do not touch this product's housing during operation because it may be very hot.

#### Mounting and Rigging

- This product is not intended for permanent installation.
- This product is for indoor use only! To prevent risk of fire or shock, do not expose this product to rain or moisture. (IP20)
- CAUTION: When transferring product from extreme temperature environments, (e.g., cold truck to warm humid ballroom) condensation may form on the internal electronics of the product. To avoid causing a failure, allow product to fully acclimate to the surrounding environment before connecting it to power.
- Mount this product in a location with adequate ventilation, at least 20 in (50 cm) from adjacent surfaces.
- Make sure there are no flammable materials close to this product while it is operating.
- When hanging this product, always secure to a fastening device using a safety cable.
- Never carry the product by the power cord or any moving part.

#### Power and Wiring

- Make sure the power cord is not crimped or damaged.
- Always make sure you are connecting this product to the proper voltage in accordance with the specifications in this manual or on the product's specification label.
- To eliminate unnecessary wear and improve its lifespan, during periods of non-use completely disconnect the product from power via breaker or by unplugging it.
- Never connect this product to a dimmer pack or rheostat.
- Make sure to replace the fuse with another of the same type and rating.
- Never disconnect this product by pulling or tugging on the power cable.

#### Operation

- Do not operate this product if you see damage on the housing, lenses, or cables. Have the damaged parts replaced by an authorized technician at once.
- Do not cover the ventilation slots when operating to avoid internal overheating.
- The maximum ambient temperature is 113 °F (45 °C). Do not operate this product at a higher temperature.
- In case of a serious operating problem, stop using this product immediately!



**If your Chauvet product requires service, contact Chauvet Technical Support.**

### Expected LED Lifespan

Over time, use and heat will gradually reduce LED brightness. Clustered LEDs produce more heat than single LEDs, contributing to shorter lifespans if always used at full intensity. The average LED lifespan is 40,000 to 50,000 hours. To extend LED lifespan, maintain proper ventilation around the product, and limit the overall intensity.

## 2. INTRODUCTION

**Description** The Rogue R1 FX-B is a fully featured RGBW LED yoke effect beam product with continuous movement of the pan and each of the five autonomous tilt functions. Pixel map the five beams for unique effects. The Rogue R1 FX-B runs on DMX, Art-Net™, sACN, and Kling-Net protocols, and can be controlled with lighting consoles or media servers, providing the ultimate in flexible control integration options. Convert TCP/IP protocols into DMX output for shorter cable runs.

- Features**
- 5 RGBW 15 W LEDs
  - Tight 7° beams.
  - 5,361 lux at 5 meters
  - Continuous and-fast pan/tilt movement
  - Control options include DMX, Art-Net™, sACN, and Kling-Net
  - Neutrik® powerCON® in and out ports
  - Amphenol XLRnet through ports
  - DMX 3- and 5-pin in and out ports
  - Built-in TCP/IP to DMX converter
  - Built-in web server for remote diagnostics and firmware upgrades

### Overview

#### Front View

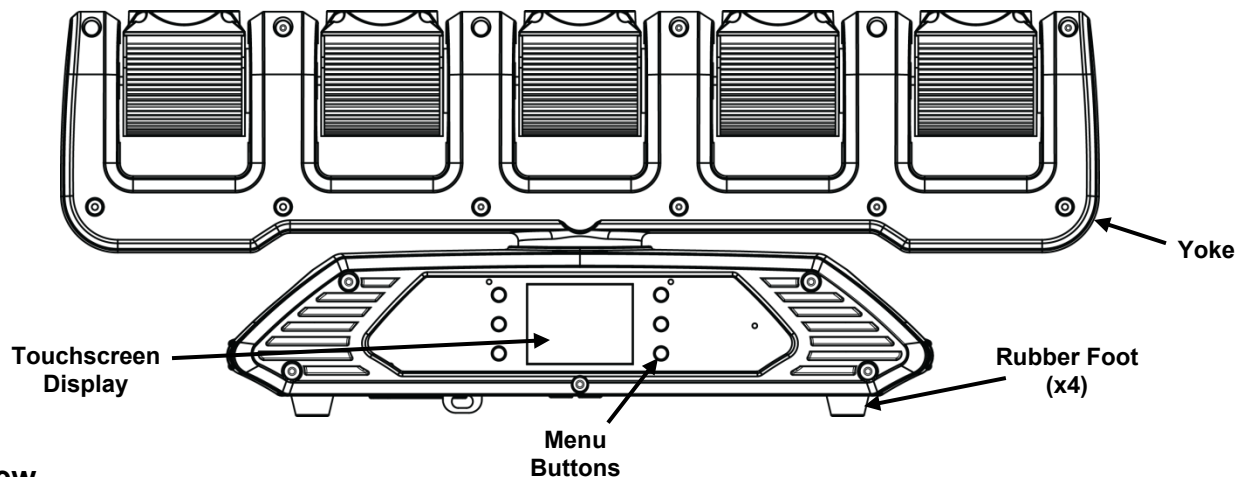

#### Rear View

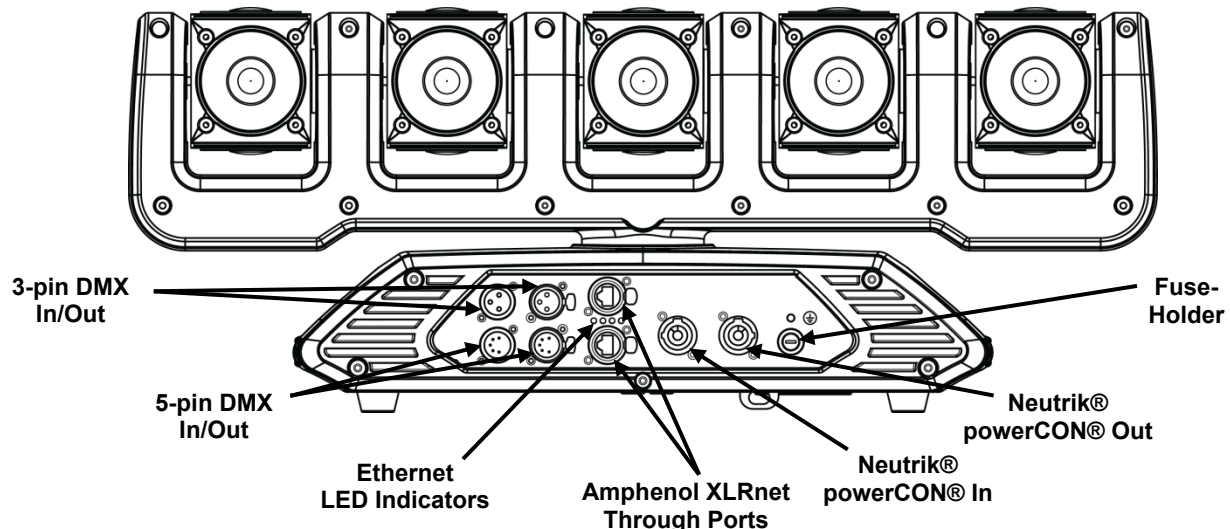

## Dimensions

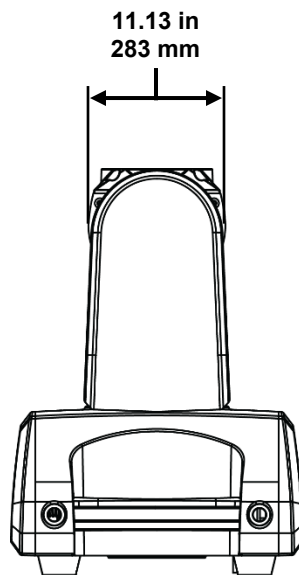
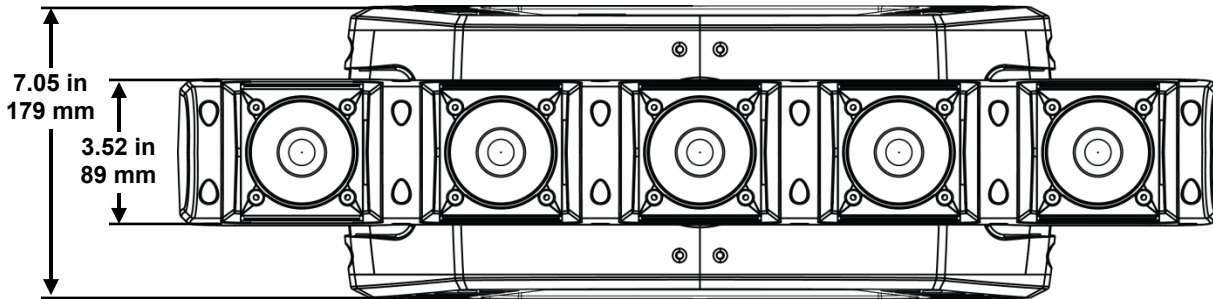
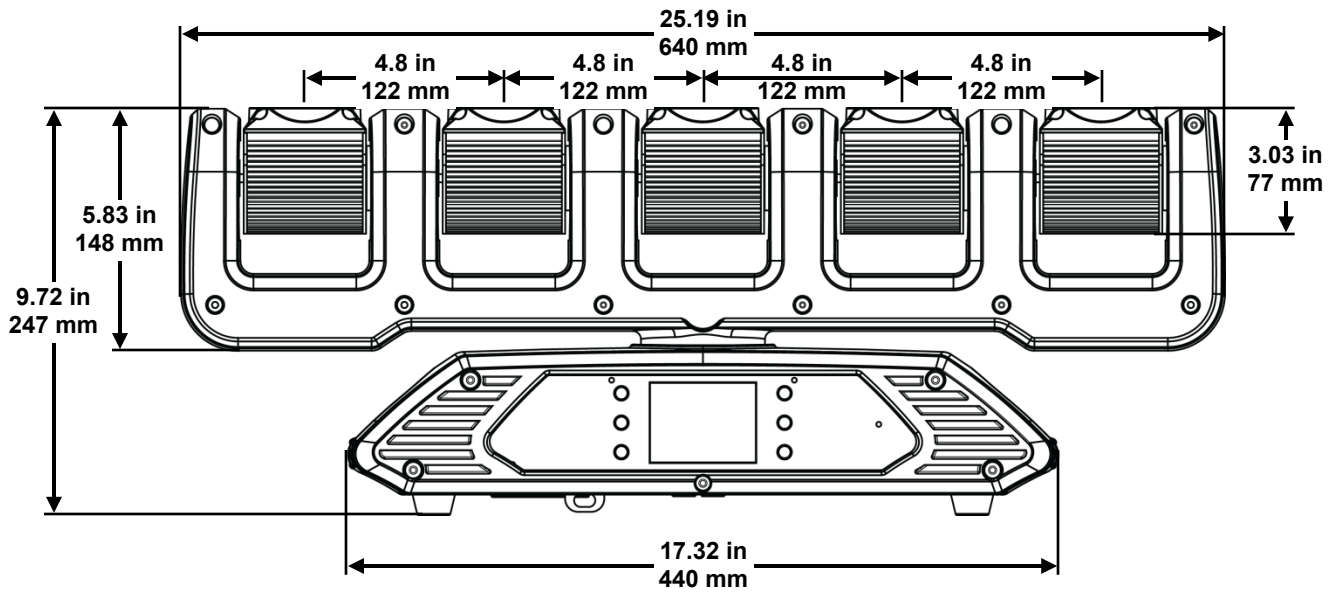



### 3. SETUP

#### AC Power

Each Rogue R1 FX-B has an auto-ranging power supply that works with an input voltage range of 100 to 240 VAC, 50/60 Hz. To determine the power requirements for each Rogue R1 FX-B, refer to the label affixed to the product. You can also refer to the [Technical Specifications](#) chart in this manual.

The listed current rating indicates the maximum current draw during normal operation. For more information, you may download Sizing Circuit Breakers from the Chauvet website: [www.chauvetprofessional.com](http://www.chauvetprofessional.com).



- **Always connect this product to a protected circuit with an appropriate electrical ground to avoid the risk of electrocution or fire.**
- **Never connect this product to a rheostat (variable resistor) or dimmer circuit, even if the rheostat or dimmer channel serves only as a 0 to 100% switch.**
- **To eliminate unnecessary wear and improve its lifespan, during periods of non-use completely disconnect the product from power via breaker or by unplugging it.**

#### AC Plug

The Rogue R1 FX-B comes with a power input cord terminated with a Neutrik® powerCON® connector on one end and an Edison plug on the other end (U.S. market). If the power input cord that came with your product has no plug, or if you need to change the Edison plug, use the table below to wire the new plug.

Connection	Wire (U.S.)	Wire (Europe)	Screw Color
AC Live	Black	Brown	Yellow or Brass
AC Neutral	White	Blue	Silver
AC Ground	Green/Yellow	Green/Yellow	Green

#### Fuse Replacement

1. Disconnect this product from the power outlet.
2. Using a flat-head screwdriver, unscrew the fuse holder cap from the housing.
3. Remove the blown fuse and replace with another fuse of the same type and rating (F 3 A, 250 V).
4. Screw the fuse holder cap back in place and reconnect power.



**Make sure to disconnect the product's power cord before replacing a blown fuse. Always replace the blown fuse with another of the same type and rating.**

#### Power Linking

It is possible to link up to 6 Rogue R1 FX-B products at 100 V, 8 products at 120 V, 15 products at 208 V, or up to 16 products at 230 V or 240 V. Never exceed this number.

This product comes with a power input cord. Power linking cables are available from Chauvet for purchase.

Power Linking Diagram

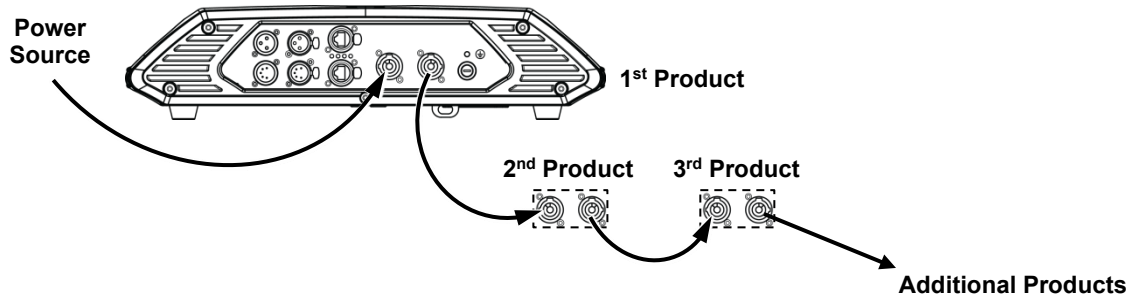

**Mounting** Before mounting this product, read and follow the [Safety Notes](#). For our CHAUVET Professional line of mounting clamps, go to <http://trusst.com/products/>.

**Orientation** Always mount this product in a safe position and make sure there is adequate room for ventilation, configuration, and maintenance. The Rogue R1 FX-B can be suspended upright or upside down using the 2 Omega brackets included, or it can be placed on its rubber feet on a flat level surface.

Chauvet recommends using the following general guidelines when mounting this product:

- When selecting an installation location, consider easy access to this product for operation, programming adjustments, and routine maintenance.
- The product is not intended for permanent installation.
- Make sure to mount this product away from any flammable material as indicated in the [Safety Notes](#).
- Never mount in places where rain, high humidity, extreme temperature changes, or restricted ventilation may affect the product.
- If hanging this product, make sure that the mounting location can support the product's weight. See the [Technical Specifications](#) for the weight-bearing requirements of this product.
- When hanging this product, always secure to a fastening device using a safety cable. For our CHAUVET Professional line of safety cables, go to <http://trusst.com/products/>.
- When mounting the product on the floor, make sure that the product and cables are away from people and vehicles.
- Place the Rogue R1 FX-B so that it can move freely without hitting anything or anybody.
- Leave enough slack on the cabled to prevent tension and pull on the plugs.

### Mounting Diagram

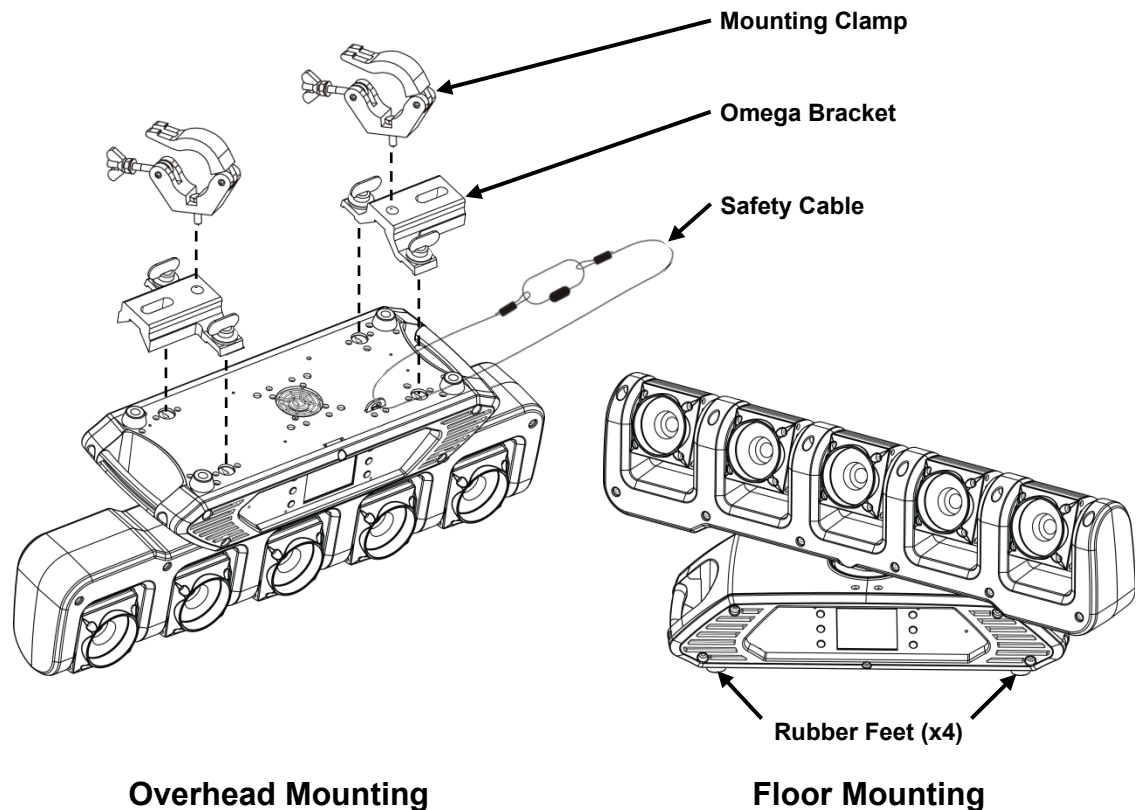

## Signal Connections

The Rogue R1 FX-B can receive DMX, Art-Net™, sACN, or Kling-Net signal. The Rogue R1 FX-B has 2 Neutrik® etherCON® through ports, and 3- and 5-pin DMX in and out ports. For more information about DMX, read the DMX primer at:

[https://www.chauvetprofessional.com/wp-content/uploads/2016/06/DMX\\_Primer.pdf](https://www.chauvetprofessional.com/wp-content/uploads/2016/06/DMX_Primer.pdf).

### Art-Net™ Connection

Art-Net™ is an Ethernet protocol that uses TCP/IP which transfers a large amount of DMX512 data using an Neutrik® etherCON® RJ45 connection over a large network. An Art-Net™ protocol document is available from [www.chauvetprofessional.com](http://www.chauvetprofessional.com).

Art-Net™ designed by and copyright Artistic Licence Holdings Ltd.

### sACN Connection

Also known as ANSI E1.31, streaming ACN is an Ethernet protocol that uses the layering and formatting of Architecture for Control Networks to transport DMX512 data over IP or any other ACN compatible network. ACN is maintained by the Professional Lighting and Sound Association (PLASA).

### Kling-Net Connection

Kling-Net is a network protocol that allows auto configuration of display devices using a Neutrik® etherCON® RJ45 Ethernet connection. Refer to the ArKaos software manual for detailed instructions on programming this product.



**ArKaos Kling-Net does not support the pan and tilt functions, and must be paired with another protocol for full functionality with the Rogue R1 FX-B.**

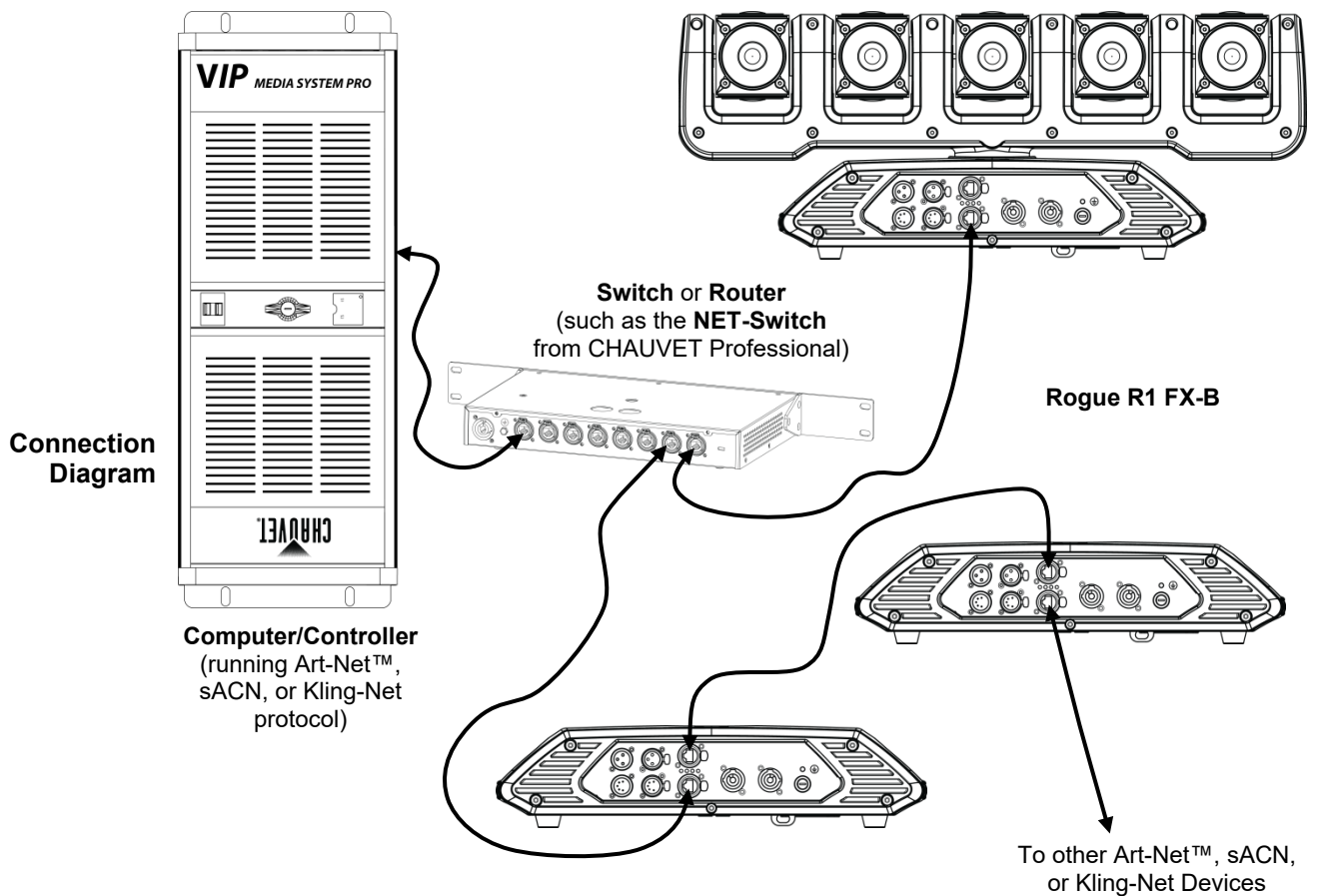

**The three LED indicators in between the Amphenol XLRnet ports indicate a connection to a network and activity on that network. They do not indicate whether or not the Rogue R1 FX-B is receiving a signal from a controller.**

## 4. OPERATION

### Touchscreen Control Panel

The Rogue R1 FX-B has a touchscreen display as well as 6 control buttons. Navigate the menu structure by pressing the buttons, touching the images of the buttons on the sides of the display, or touching the desired menu option on the display directly. The touchscreen can be locked and calibrated through the **Setup** options in the menu. (see [Touchscreen Calibration](#) and [Touchscreen Lock](#))

### Control Panel Description

Button	Function
	Navigates upwards through the menu list or increases the numeric value when in a function
	Exits from the current menu or function
	Navigates downwards through the menu list or decreases the numeric value when in a function
	Navigates leftwards through the menu list
	Enables the currently displayed menu or sets the currently selected value into the selected function
	Navigates rightwards through the menu list

### Battery Powered Display

Press and hold until menu screen appears (approx 15 sec.).

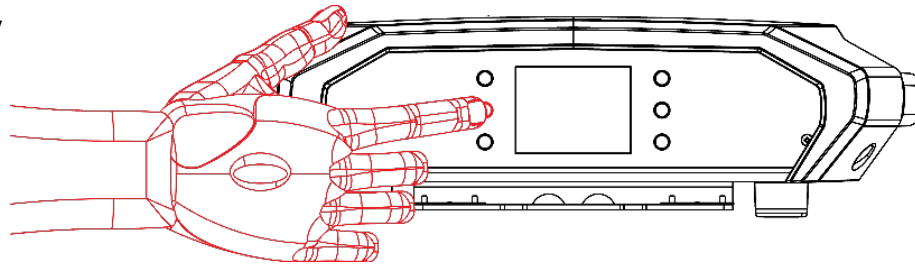

### Menu Map

Refer to the Rogue R1 FX-B product page on [www.chauvetprofessional.com](http://www.chauvetprofessional.com) for the latest menu map.

Main Level	Programming Levels			Description		
Control Settings	Single Control	DMX	Personality	Basic	Sets the DMX personality, from Basic (18CH), Standard (25CH), Advanced (47CH), Tour (47CH) or Tour 2 (52CH)	
				Standard		
				Advanced		
				Tour		
				Tour 2		
				Start Address	001-512	Sets the DMX starting address
		ArtNet	Personality	Personality	Basic	Sets the Art-Net™ personality, from Basic (18CH), Standard (25CH), Advanced (47CH), Tour (47CH) or Tour 2 (52CH)
					Standard	
					Advanced	
					Tour	
	Tour 2					
			Start Address	001-512	Sets the Art-Net™ starting address	
			Universe	0-254	Sets the Art-Net™ universe	
	sACN	Personality	Personality	Basic	Sets the sACN personality, from Basic (18CH), Standard (25CH), Advanced (47CH), Tour (47CH) or Tour 2 (52CH)	
				Standard		
Advanced						
Tour						
Tour 2						
		Start Address	001-512	Sets the sACN starting address		
		Universe	0-255	Sets the sACN universe		

Main Level	Programming Levels				Description			
Control Settings (cont.)	Dual Control	Movement	DMX	Personality	Basic	Sets the DMX personality, from Basic (10CH), Standard (17CH), or Advanced (23CH)		
					Standard			
					Advanced			
			Start Address	001-512	Sets the DMX starting address			
				ArtNet		Personality	Basic	Sets the Art-Net™ personality, from Basic (10CH), Standard (17CH), or Advanced (23CH)
							Standard	
			Advanced					
			Start Address	001-512	Sets the Art-Net™ starting address			
				Universe		0-254	Sets the Art-Net™ universe	
						sACN		Personality
			Standard					
			Advanced					
		Start Address	001-512	Sets the sACN starting address				
			Universe		0-255	Sets the sACN universe		
					DMX		Personality	RGB
		RGBW						
		Start Address	001-512	Sets the DMX starting address				
			ArtNet		Personality	RGB	Sets the Art-Net™ personality, from RGB (15CH) or RGBW (20CH)	
						RGBW		
		Start Address		001-512		Sets the Art-Net™ starting address		
			Universe	0-254	Sets the Art-Net™ universe			
				sACN			Personality	RGB
		RGBW						
		Start Address	001-512		Sets the sACN starting address			
Universe	0-255		Sets the sACN universe					
	KlingNet			Personality		RGB	Sets the Kling-Net personality, from RGB (15CH) or RGBW (20CH)	
		RGBW						
Start Address		001-512	Sets the Kling-Net starting address					



In Dual Control mode, the Movement protocol and the Pixel protocol cannot be the same.

# Operation



Main Level	Programming Levels		Description	
Test Mode	Manual test	Auto test	Auto test all functions	
		Pan	000–255	
		Pan Speed		
		Pan 360		
		Tilt 1		
		Tilt 2		
		Tilt 3		
		Tilt 4		
		Tilt 5		
		Tilt Speed		
		Tilt 1 360		
		Tilt 2 360		
		Tilt 3 360		
		Tilt 4 360		
		Tilt 5 360		
		Dimmer		
		Shutter		
		Red		
		Green		
		Blue		
White				
Color				
LED Macro				
LED Macro Speed				
Setup	Network Settings	IP Mode	Manual	Manually set IP address
			DHCP	Network sets IP address
		IP Mode	Static	Product sets IP address
		IP	-----	Set IP address in Manual mode
		SubMask	-----	Set Subnet Mask in Manual mode
		NO	Normal pan	
		YES	Reversed pan	
	Pan Reverse	NO		Normal tilt
		YES		Reversed tilt
	Tilt Reverse	NO		Normal display
		YES		Inverted display
	Screen Reverse	AUTO		Automatic display orientation
		540		540° pan range
		360		360° pan range
	Pan Angle	180		180° pan range
		540		540° tilt range
		270		270° tilt range
	Tilt Angle	180		180° tilt range
		NO		Do not black out while panning/tilting
YES			Black out while panning/tilting	
BL. O. P/T Move	NO		Keep current settings	
	YES		Calibrate touchscreen	
Calibration				

Main Level	Programming Levels		Description	
Setup (cont.)	Touchscreen Lock	NO	Display responds to touch	
		YES	Display does not respond to touch	
	Lock Screen	NO	Locks the buttons and touchscreen. Passcode to unlock: 0920	
		YES		
	Backlight Timer	30S	Display turns off after 30 seconds	
		1M	Display turns off after 1 minute	
		5M	Display turns off after 5 minutes	
		ON	Display stays on at all times	
	Loss of Data	Hold	Hold last signal received at signal loss	
		Close	Black out the product at signal loss	
	C Mixing Mode	RGBW	Additive color mixing (0=0, 255=100%)	
		CMY	Subtractive color mixing (0=100%, 255=0)	
	Dimmer Curve	Linear	Set the dimmer curve	
		Square		
		I Squa		
		SCurve		
	Dimmer Speed	Smooth	Set the dimmer speed	
		Fast		
	PWM Option	600Hz	Selects the PWM output frequency	
		1200Hz		
		2000Hz		
		4000Hz		
		6000Hz		
	Color Balance	Red	100–255	Sets red LED maximum value
		Green		Sets green LED maximum value
		Blue		Sets blue LED maximum value
		White		Sets white LED maximum value
Preset Select	PRESET A		Recorded preset menu options	
	PRESET B			
	PRESET C			
Preset Sync	NO		Allows recorded preset menu options to be transferred to other Rogue R1 FX-Bs in the DMX daisy chain	
	YES			
Reset Function	Pan	NO	Reset individual functions or all functions from start-up	
		YES		
	Tilt	NO		
		YES		
All	NO			
	YES			
Factory Settings	NO		Reset to factory default settings	
	YES			
Sys Info	Fixture Information	Ver	V_	Shows firmware version
		Running Mode	---	Shows current running mode
		Address	---	Shows current starting address
		Temperature	--	Shows current product temperature in °C
		Fixture Hours	-----	Shows number of hours product has been powered on
		IP	-----	Shows current IP address
		SubMask	-----	Shows current Subnet Mask
		MAC	-----	Shows current MAC address
Error Information	No Error!*		Shows any errors, or No Error!	

# Operation



Main Level	Programming Levels		Description
Sys Info (cont.)	Channel Information	Frequency	---
		Pan	
		Pan Fine	
		Pan 360	
		Tilt 1	
		Tilt 1 Fine	
		Tilt 2	
		Tilt 2 Fine	
		Tilt 3	
		Tilt 3 Fine	
		Tilt 4	
		Tilt 4 Fine	
		Tilt 5	
		Tilt 5 Fine	
		Tilt 1 360	
		Tilt 2 360	
		Tilt 3 360	
		Tilt 4 360	
		Tilt 5 360	
		Y Macro	
		Y Macro Speed	
		Function	
		Dimmer	
		Shutter	
		Color	
		Lamp Number	
		LED Macro	
		LED Ma. Speed	
		Red 1	
		Green 1	
		Blue 1	
		White 1	
		Red 2	
		Green 2	
		Blue 2	
		White 2	
		Red 3	
		Green 3	
		Blue 3	
		White 3	
		Red 4	
		Green 4	
Blue 4			
White 4			
Red 5			
Green 5			
Blue 5			
White 5			

Shows all current values from input signals, 000–255



## Protocol Configuration

The Rogue R1 FX-B can be set to respond to DMX, Art-Net™, sACN, Kling-Net, or a combination of those protocols. The protocol configuration must be set for the product to respond correctly to the controller(s). See the [Menu Map](#) for more information.

### Single Control

In Single Control mode, the Rogue R1 FX-B is controlled by a single protocol input. Choose from DMX, Art-Net™, or sACN. In this mode, the four personalities available are **Basic** (18 channels), **Standard** (25 channels), **Advanced** (47 channels), **TOUR** (47CH) and **TOUR 2** (52CH).

#### Single Control Protocol

To select the Single Control protocol, follow the instructions below:

1. Press **<MENU>** repeatedly until the [Home Screen](#) shows on the display. Press **<ENTER>**.
2. Use **<UP>**, **<DOWN>**, **<LEFT>**, or **<RIGHT>** to select **Control Settings**, or touch the display where it says **Control Settings**.
3. If using the buttons instead of the touchscreen, press **<ENTER>**.
4. Use **<UP>** or **<DOWN>** to select **Single Control**, or touch the display where it says **Single Control**.
5. If using the buttons instead of the touchscreen, press **<ENTER>**.
6. Use **<UP>** or **<DOWN>** to select from **DMX**, **ArtNet**, or **sACN**, or touch the display where it says the desired protocol option.
7. If using the buttons instead of the touchscreen, press **<ENTER>**.

#### Single Control Personality

To select the Single Control personality, set the [Protocol](#), then do the following:

1. Use **<UP>** or **<DOWN>** to select **Personality**, or touch the display where it says **Personality**.
2. If using the buttons instead of the touchscreen, press **<ENTER>**.
3. Use **<UP>**, **<DOWN>**, **<LEFT>**, or **<RIGHT>** to select from **Basic** (18-channel), **Standard** (25-channel), **Advanced** (47-channel), **TOUR** (47CH) or **TOUR 2** (52CH), or touch the display where it says the desired personality.
4. If using the buttons instead of the touchscreen, press **<ENTER>**.

#### Single Control Start Address

To set the starting address of the Single Control mode, set the [Protocol](#), then follow the instructions below:

1. Use **<UP>** or **<DOWN>** to select **Start Address**, or touch the display where it says **Start Address**.
2. If using the buttons instead of the touchscreen, press **<ENTER>**.
3. Enter the starting address (**001–512**) with one of the following methods:
  - Type the address number using the number pad that shows on the touchscreen display. or
  - Using the buttons (or the button icons on the sides of the display),
    - a. Use **<LEFT>** or **<RIGHT>** to select the digit to be altered.
    - b. Use **<UP>** or **<DOWN>** to increase or decrease the number value of that digit.
    - c. Repeat until the address is set as desired.
4. Press **<ENTER>**.

#### Single Control Universe

To set the Universe address of the Single Control mode when using Art-Net™ or sACN, set the [Protocol](#) to **ArtNet** or **sACN**, then do the following:

1. Use **<UP>** or **<DOWN>** to select **Universe**, or touch the display where it says **Universe**.
2. If using the buttons instead of the touchscreen, press **<ENTER>**.
3. Enter the universe address (**0–254** for **ArtNet**, **0–255** for **sACN**) with one of the following methods:
  - Type the universe number using the number pad that shows on the touchscreen display. or
  - Using the buttons (or the button icons on the sides of the display),
    - a. Use **<LEFT>** or **<RIGHT>** to select the digit to be altered.
    - b. Use **<UP>** or **<DOWN>** to increase or decrease the number value of that digit.
    - c. Repeat until the universe is set as desired.
4. Press **<ENTER>**.

## Dual Control

In Dual Control mode, the Rogue R1 FX-B is controlled by two protocol inputs. One controls the movement of the yoke as well as the dimmer and shutter, while the other controls the individual LED output.

**Dual Control Movement** The Movement protocol controls the movement of the yoke as well as the dimmer and shutter. Choose from DMX, Art-Net™, or sACN. In this mode, the three personalities available are **Basic** (10 channels), **Standard** (17 channels), and **Advanced** (23 channels).

**Dual Control Movement Protocol** To select the Dual Control Movement protocol, follow the instructions below:

1. Press **<MENU>** repeatedly until the [Home Screen](#) shows on the display. Press **<ENTER>**.
2. Use **<UP>**, **<DOWN>**, **<LEFT>**, or **<RIGHT>** to select **Control Settings**, or touch the display where it says **Control Settings**.
3. If using the buttons instead of the touchscreen, press **<ENTER>**.
4. Use **<UP>** or **<DOWN>** to select **Dual Control**, or touch the display where it says **Dual Control**.
5. If using the buttons instead of the touchscreen, press **<ENTER>**.
6. Use **<UP>** or **<DOWN>** to select **Movement**, or touch the display where it says **Movement**.
7. If using the buttons instead of the touchscreen, press **<ENTER>**.
8. Use **<UP>**, **<DOWN>**, **<LEFT>**, or **<RIGHT>** to select from **DMX**, **ArtNet**, or **sACN**, or touch the display where it says the desired protocol option.
9. If using the buttons instead of the touchscreen, press **<ENTER>**.

**Dual Control Movement Personality** To select the Dual Control Movement personality, set the [Protocol](#), then do the following:

1. Use **<UP>** or **<DOWN>** to select **Personality**, or touch the display where it says **Personality**.
2. If using the buttons instead of the touchscreen, press **<ENTER>**.
3. Use **<UP>**, **<DOWN>**, **<LEFT>**, or **<RIGHT>** to select from **Basic** (10-channel), **Standard** (17-channel), or **Advanced** (23-channel), or touch the display where it says the desired personality.
4. If using the buttons instead of the touchscreen, press **<ENTER>**.

**Dual Control Movement Start Address** To set the starting address of the Dual Control Movement mode, set the [Protocol](#), then follow the instructions below:

1. Use **<UP>** or **<DOWN>** to select **Start Address**, or touch the display where it says **Start Address**.
2. If using the buttons instead of the touchscreen, press **<ENTER>**.
3. Enter the starting address (**001–512**) with one of the following methods:
  - Type the address number using the number pad that shows on the touchscreen display. or
  - Using the buttons (or the button icons on the sides of the display),
    - a. Use **<LEFT>** or **<RIGHT>** to select the digit to be altered.
    - b. Use **<UP>** or **<DOWN>** to increase or decrease the number value of that digit.
    - c. Repeat until the address is set as desired.
4. Press **<ENTER>**.

**Dual Control Movement Universe** To set the Universe address of the Dual Control Movement mode when using Art-Net™ or sACN, set the [Protocol](#) to **ArtNet** or **sACN**, then do the following:

1. Use **<UP>** or **<DOWN>** to select **Universe**, or touch the display where it says **Universe**.
2. If using the buttons instead of the touchscreen, press **<ENTER>**.
3. Enter the universe address (**0–254** for **ArtNet**, **0–255** for **sACN**) with one of the following methods:
  - Type the universe number using the number pad that shows on the touchscreen display. or
  - Using the buttons (or the button icons on the sides of the display),
    - a. Use **<LEFT>** or **<RIGHT>** to select the digit to be altered.
    - b. Use **<UP>** or **<DOWN>** to increase or decrease the number value of that digit.
    - c. Repeat until the universe is set as desired.
4. Press **<ENTER>**.

**Dual Control Pixel** The Pixel protocol controls the individual output of the LEDs. Choose from DMX, Art-Net™, sACN, or Kling-Net. In this mode, the two personalities available are **RGB** (15 channels), and **RGBW** (20 channels).

- Dual Control Pixel Protocol** To select the Dual Control Pixel protocol, follow the instructions below:
1. Press **<MENU>** repeatedly until the [Home Screen](#) shows on the display. Press **<ENTER>**.
  2. Use **<UP>**, **<DOWN>**, **<LEFT>**, or **<RIGHT>** to select **Control Settings**, or touch the display where it says **Control Settings**.
  3. If using the buttons instead of the touchscreen, press **<ENTER>**.
  4. Use **<UP>** or **<DOWN>** to select **Dual Control**, or touch the display where it says **Dual Control**.
  5. If using the buttons instead of the touchscreen, press **<ENTER>**.
  6. Use **<UP>** or **<DOWN>** to select **Pixel**, or touch the display where it says **Pixel**.
  7. If using the buttons instead of the touchscreen, press **<ENTER>**.
  8. Use **<UP>**, **<DOWN>**, **<LEFT>**, or **<RIGHT>** to select from **DMX**, **ArtNet**, **sACN**, or **KlingNet**, or touch the display where it says the desired protocol option.
  9. If using the buttons instead of the touchscreen, press **<ENTER>**.

- Dual Control Pixel Personality** To select the Dual Control Pixel personality, set the [Protocol](#), then do the following:
1. Use **<UP>** or **<DOWN>** to select **Personality**, or touch the display where it says **Personality**.
  2. If using the buttons instead of the touchscreen, press **<ENTER>**.
  3. Use **<UP>**, **<DOWN>**, **<LEFT>**, or **<RIGHT>** to select from **RGB** (15-channel) or **RGBW** (20-channel), or touch the display where it says the desired personality.
  4. If using the buttons instead of the touchscreen, press **<ENTER>**.

- Dual Control Pixel Start Address** To set the starting address of the Dual Control Pixel mode, set the [Protocol](#), then follow the instructions below:
1. Use **<UP>** or **<DOWN>** to select **Start Address**, or touch the display where it says **Start Address**.
  2. If using the buttons instead of the touchscreen, press **<ENTER>**.
  3. Enter the starting address (**001–512**) with one of the following methods:
    - Type the address number using the number pad that shows on the touchscreen display. or
    - Using the buttons (or the button icons on the sides of the display),
      - a. Use **<LEFT>** or **<RIGHT>** to select the digit to be altered.
      - b. Use **<UP>** or **<DOWN>** to increase or decrease the number value of that digit.
      - c. Repeat until the address is set as desired.
  4. Press **<ENTER>**.

- Dual Control Pixel Universe** To set the Universe address of the Dual Control Pixel mode when using Art-Net™ or sACN, set the [Protocol](#) to **ArtNet** or **sACN**, then do the following:
1. Use **<UP>** or **<DOWN>** to select **Universe**, or touch the display where it says **Universe**.
  2. If using the buttons instead of the touchscreen, press **<ENTER>**.
  3. Enter the universe address (**0–254** for **ArtNet**, **0–255** for **sACN**) with one of the following methods:
    - Type the universe number using the number pad that shows on the touchscreen display. or
    - Using the buttons (or the button icons on the sides of the display),
      - a. Use **<LEFT>** or **<RIGHT>** to select the digit to be altered.
      - b. Use **<UP>** or **<DOWN>** to increase or decrease the number value of that digit.
      - c. Repeat until the universe is set as desired.
  4. Press **<ENTER>**.

## Zones for Pixel control

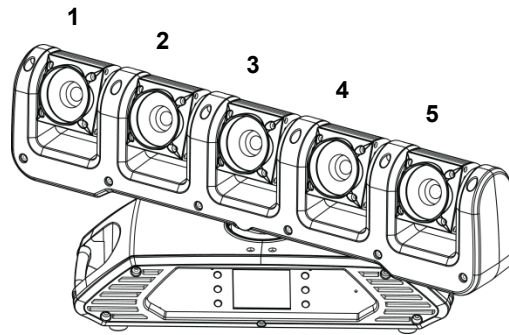

## DMX Values

### Single Control Values

Tour 2 (52-channel)	Channel	Function	Value	Percent/Settings
	1	Pan	000 ⇄ 255	0–100%
	2	Fine Pan	000 ⇄ 255	0–100%
	3	Continuous Pan	000	No function
			001 ⇄ 127	Counterclockwise rotation, slow to fast
			128	Stop
			129 ⇄ 255	Clockwise rotation, slow to fast
	4	Tilt Macro	000 ⇄ 047	No function
			048 ⇄ 055	Tilt Macro 1
			056 ⇄ 063	Tilt Macro 2
			064 ⇄ 071	Tilt Macro 3
			072 ⇄ 079	Tilt Macro 4
			080 ⇄ 087	Tilt Macro 5
			088 ⇄ 095	Tilt Macro 6
			096 ⇄ 103	Tilt Macro 7
			104 ⇄ 111	Tilt Macro 8
			112 ⇄ 119	Tilt Macro 9
			120 ⇄ 127	Tilt Macro 10
			128 ⇄ 135	Tilt Macro 11
			136 ⇄ 143	Tilt Macro 12
			144 ⇄ 151	Tilt Macro 13
			152 ⇄ 159	Tilt Macro 14
			160 ⇄ 167	Tilt Macro 15
			168 ⇄ 175	Tilt Macro 16
			176 ⇄ 183	Tilt Macro 17
			184 ⇄ 191	Tilt Macro 18
			192 ⇄ 199	Tilt Macro 19
			200 ⇄ 207	Tilt Macro 20
			208 ⇄ 215	Tilt Macro 21
			216 ⇄ 223	Tilt Macro 22
			224 ⇄ 231	Tilt Macro 23
			232 ⇄ 239	Tilt Macro 24
			240 ⇄ 247	Tilt Macro 25
	248 ⇄ 255	Tilt Macro 26		
	5	Tilt Macro Speed	000 ⇄ 255	Fast to slow

Tour 2  
(52-channel cont.)

Channel	Function	Value	Percent/Settings
6	Control	000 ⇄ 009	No function
		010 ⇄ 014	Manual tilt blackout
		015 ⇄ 019	Cancel manual tilt blackout
		020 ⇄ 024	1 fixture macro
		025 ⇄ 029	2 fixture macro 1
		030 ⇄ 034	2 fixture macro 2
		035 ⇄ 039	4 fixture macro 1
		040 ⇄ 044	4 fixture macro 2
		045 ⇄ 049	4 fixture macro 3
		050 ⇄ 054	4 fixture macro 4
		055 ⇄ 059	Pan reset
		060 ⇄ 064	Tilt reset
		065 ⇄ 069	No function (reserved for future use)
		070 ⇄ 074	Reset all
		075 ⇄ 079	No function (reserved for future use)
		080 ⇄ 084	Pan/Tilt reverse
		085 ⇄ 089	Pan reverse
		090 ⇄ 094	Tilt reverse
		095 ⇄ 099	Cancel pan reverse
		100 ⇄ 104	Cancel tilt reverse
		105 ⇄ 109	Cancel pan/tilt reverse
		110 ⇄ 114	No function (reserved for future use)
		115 ⇄ 119	Link all heads to head 1
		120 ⇄ 124	Unlink all heads from head 1
125 ⇄ 134	No function (reserved for future use)		
135 ⇄ 139	Dimmer speed mode fast		
140 ⇄ 144	Dimmer speed mode smooth		
145 ⇄ 255	No function		
7	Dimmer	000 ⇄ 255	0–100%
8	Shutter	000 ⇄ 019	Off
		020 ⇄ 024	On
		025 ⇄ 064	Strobe 1, fast to slow
		065 ⇄ 069	On
		070 ⇄ 084	Strobe 2 (Fast on, slow off), fast to slow
		085 ⇄ 089	On
		090 ⇄ 104	Strobe 3 (Slow on, fast off), fast to slow
		104 ⇄ 109	On
		110 ⇄ 124	Strobe 4 (Random), fast to slow
		125 ⇄ 129	On
		130 ⇄ 144	Strobe 5 (Random fast on, slow off), fast to slow
		145 ⇄ 149	On
		150 ⇄ 164	Strobe 6 (Random slow on, fast off), fast to slow
		165 ⇄ 169	On
		170 ⇄ 184	Strobe 7 (Pulse), fast to slow
		185 ⇄ 189	On
		190 ⇄ 204	Strobe 8 (Random pulse), fast to slow
		205 ⇄ 209	On
		210 ⇄ 224	Strobe 9 (Fade in, fade out), fast to slow
		225 ⇄ 229	On
230 ⇄ 244	Strobe 10 (Random pulse), fast to slow		
245 ⇄ 255	On		

## Operation



Tour 2 (52-channel cont.)	Channel	Function	Value	Percent/Settings
	<b>9</b>	<b>Color Macro</b>	000 ⇔ 013	No function
			014 ⇔ 020	Color 1
			021 ⇔ 028	Color 2
			029 ⇔ 036	Color 3
			037 ⇔ 044	Color 4
			045 ⇔ 052	Color 5
			053 ⇔ 060	Color 6
			061 ⇔ 068	Color 7
			069 ⇔ 076	Color 8
			077 ⇔ 084	Color 9
			085 ⇔ 092	Color 10
			093 ⇔ 100	Color 11
			101 ⇔ 108	Color 12
			109 ⇔ 116	Color 13
			117 ⇔ 124	Color 14
			125 ⇔ 133	Color 15
			134 ⇔ 185	No function
			186 ⇔ 207	Rainbow effect, fast to slow
			208 ⇔ 213	Stop
			214 ⇔ 235	Reverse Rainbow effect, fast to slow
			236 ⇔ 240	No function
	241 ⇔ 255	Color jump, fast to slow		

Tour 2 (52-channel cont.)	Channel	Function	Value	Percent/Settings				
				Head 1	Head 2	Head 3	Head 4	Head 5
			000 ⇔ 005	●	●	●	●	●
			006 ⇔ 011	○	●	●	●	●
			012 ⇔ 017	○	○	●	●	●
			018 ⇔ 023	○	○	○	●	●
			024 ⇔ 029	○	○	○	○	●
			030 ⇔ 035	○	○	○	○	○
			036 ⇔ 041	●	○	○	○	○
			042 ⇔ 047	●	●	○	○	○
			048 ⇔ 053	●	●	●	○	○
			054 ⇔ 059	●	●	●	●	○
			060 ⇔ 065	●	●	●	●	●
			066 ⇔ 071	○	○	○	○	○
			072 ⇔ 077	●	○	○	○	○
			078 ⇔ 083	○	●	○	○	○
			084 ⇔ 089	○	○	●	○	○
			090 ⇔ 095	○	○	○	●	○
			096 ⇔ 101	○	○	○	○	●
			102 ⇔ 107	○	○	○	○	○
			108 ⇔ 113	●	●	○	○	○
			114 ⇔ 119	○	●	●	○	○
			120 ⇔ 125	○	○	●	●	○
			126 ⇔ 131	○	○	○	●	●
			132 ⇔ 137	●	○	○	○	●
			138 ⇔ 143	○	○	○	○	○
			144 ⇔ 149	○	●	●	●	●
			150 ⇔ 155	●	○	●	●	●
			156 ⇔ 161	●	●	○	●	●
			162 ⇔ 167	●	●	●	○	●
			168 ⇔ 173	●	●	●	●	○
			174 ⇔ 179	○	○	○	○	○
			180 ⇔ 185	○	○	○	○	●
			186 ⇔ 191	○	○	○	●	●
			192 ⇔ 197	○	○	●	●	●
			198 ⇔ 203	○	●	●	●	●
			204 ⇔ 209	●	●	●	●	●
			210 ⇔ 215	○	○	○	○	○
			216 ⇔ 221	●	●	●	○	○
			222 ⇔ 227	○	●	●	●	○
			228 ⇔ 233	○	○	●	●	●
			234 ⇔ 239	●	○	○	●	●
			240 ⇔ 245	●	●	○	○	●
			246 ⇔ 255	●	●	●	●	●

10 On/Off Preset  
(● = on; ○ = off)

# Operation



Tour 2 (52-channel cont.)	Channel	Function	Value	Percent/Settings
			000 ⇄ 015	No function
			016 ⇄ 020	LED Macro 1
			021 ⇄ 025	LED Macro 2
			026 ⇄ 030	LED Macro 3
			031 ⇄ 035	LED Macro 4
			036 ⇄ 040	LED Macro 5
			041 ⇄ 045	LED Macro 6
			046 ⇄ 050	LED Macro 7
			051 ⇄ 055	LED Macro 8
			056 ⇄ 060	LED Macro 9
			061 ⇄ 065	LED Macro 10
			066 ⇄ 070	LED Macro 11
			071 ⇄ 075	LED Macro 12
			076 ⇄ 080	LED Macro 13
			081 ⇄ 085	LED Macro 14
			086 ⇄ 090	LED Macro 15
			091 ⇄ 095	LED Macro 16
			096 ⇄ 100	LED Macro 17
			101 ⇄ 105	LED Macro 18
			106 ⇄ 110	LED Macro 19
			111 ⇄ 115	LED Macro 20
			116 ⇄ 120	LED Macro 21
			121 ⇄ 125	LED Macro 22
			126 ⇄ 130	LED Macro 23
			131 ⇄ 135	LED Macro 24 (cycle 1–23)
			136 ⇄ 140	Auto program 1
			141 ⇄ 145	Auto program 2
			146 ⇄ 150	Auto program 3
			151 ⇄ 155	Auto program 4
			156 ⇄ 160	Auto program 5
			161 ⇄ 165	Auto program 6
			166 ⇄ 170	Auto program 7
			171 ⇄ 175	Auto program 8
			176 ⇄ 180	Auto program 9
			181 ⇄ 185	Auto program 10
			186 ⇄ 190	Auto program 11
			191 ⇄ 195	Auto program 12
			196 ⇄ 200	Auto program 13
			201 ⇄ 205	Auto program 14
			206 ⇄ 210	Auto program 15
			211 ⇄ 215	Auto program 16
			216 ⇄ 220	Auto program 17
			221 ⇄ 225	Auto program 18
			226 ⇄ 230	Auto program 19
			231 ⇄ 235	Auto program 20
			236 ⇄ 240	Auto program 21
			241 ⇄ 245	Auto program 22
			246 ⇄ 250	Auto program 23
			251 ⇄ 255	Auto program 24 (cycle 1–23)
	<b>11</b>	<b>LED Macro/ Auto Program</b>		
	<b>12</b>	<b>LED Macro Speed</b>	000 ⇄ 255	Slow to fast



<b>Tour 2</b>		<b>Channel</b>	<b>Function</b>	<b>Value</b>	<b>Percent/Settings</b>
(52-channel cont.)		<b>13</b>	<b>Tilt 1</b>	000 ⇄ 255	0–100%
		<b>14</b>	<b>Fine Tilt 1</b>	000 ⇄ 255	0–100%
		<b>15</b>	<b>Continuous Tilt 1</b>	000	No function
				001 ⇄ 127	Counterclockwise rotation, slow to fast
				128	Stop
				129 ⇄ 255	Clockwise rotation, slow to fast
		<b>16</b>	<b>Head 1 Dimmer</b>	000 ⇄ 255	0–100%
		<b>17</b>	<b>Head 1 Red</b>	000 ⇄ 255	RGBW mode: 0–100% / CMY mode: 100%–0
		<b>18</b>	<b>Head 1 Green</b>	000 ⇄ 255	RGBW mode: 0–100% / CMY mode: 100%–0
		<b>19</b>	<b>Head 1 Blue</b>	000 ⇄ 255	RGBW mode: 0–100% / CMY mode: 100%–0
		<b>20</b>	<b>Head 1 White</b>	000 ⇄ 255	RGBW mode: 0–100% / CMY mode: 100%–0
		<b>21</b>	<b>Tilt 2</b>	000 ⇄ 255	0–100%
		<b>22</b>	<b>Fine Tilt 2</b>	000 ⇄ 255	0–100%
		<b>23</b>	<b>Continuous Tilt 2</b>	000	No function
				001 ⇄ 127	Counterclockwise rotation, slow to fast
				128	Stop
				129 ⇄ 255	Clockwise rotation, slow to fast
		<b>24</b>	<b>Head 2 Dimmer</b>	000 ⇄ 255	0–100%
		<b>25</b>	<b>Head 2 Red</b>	000 ⇄ 255	RGBW mode: 0–100% / CMY mode: 100%–0
		<b>26</b>	<b>Head 2 Green</b>	000 ⇄ 255	RGBW mode: 0–100% / CMY mode: 100%–0
		<b>27</b>	<b>Head 2 Blue</b>	000 ⇄ 255	RGBW mode: 0–100% / CMY mode: 100%–0
		<b>28</b>	<b>Head 2 White</b>	000 ⇄ 255	RGBW mode: 0–100% / CMY mode: 100%–0
		<b>29</b>	<b>Tilt 3</b>	000 ⇄ 255	0–100%
		<b>30</b>	<b>Fine Tilt 3</b>	000 ⇄ 255	0–100%
		<b>31</b>	<b>Continuous Tilt 3</b>	000	No function
				001 ⇄ 127	Counterclockwise rotation, slow to fast
				128	Stop
				129 ⇄ 255	Clockwise rotation, slow to fast
		<b>32</b>	<b>Head 3 Dimmer</b>	000 ⇄ 255	0–100%
		<b>33</b>	<b>Head 3 Red</b>	000 ⇄ 255	RGBW mode: 0–100% / CMY mode: 100%–0
		<b>34</b>	<b>Head 3 Green</b>	000 ⇄ 255	RGBW mode: 0–100% / CMY mode: 100%–0
		<b>35</b>	<b>Head 3 Blue</b>	000 ⇄ 255	RGBW mode: 0–100% / CMY mode: 100%–0
		<b>36</b>	<b>Head 3 White</b>	000 ⇄ 255	RGBW mode: 0–100% / CMY mode: 100%–0
		<b>37</b>	<b>Tilt 4</b>	000 ⇄ 255	0–100%
		<b>38</b>	<b>Fine Tilt 4</b>	000 ⇄ 255	0–100%
		<b>39</b>	<b>Continuous Tilt 4</b>	000	No function
				001 ⇄ 127	Counterclockwise rotation, slow to fast
				128	Stop
				129 ⇄ 255	Clockwise rotation, slow to fast

## Operation



Tour 2 (52-channel cont.)		Channel	Function	Value	Percent/Settings
	40		Head 4 Dimmer	000 ⇄ 255	0–100%
	41		Head 4 Red	000 ⇄ 255	RGBW mode: 0–100% / CMY mode: 100%–0
	42		Head 4 Green	000 ⇄ 255	RGBW mode: 0–100% / CMY mode: 100%–0
	43		Head 4 Blue	000 ⇄ 255	RGBW mode: 0–100% / CMY mode: 100%–0
	44		Head 4 White	000 ⇄ 255	RGBW mode: 0–100% / CMY mode: 100%–0
	45		Tilt 5	000 ⇄ 255	0–100%
	46		Fine Tilt 5	000 ⇄ 255	0–100%
	47		Continuous Tilt 5	000	No function
				001 ⇄ 127	Counterclockwise rotation, slow to fast
				128	Stop
				129 ⇄ 255	Clockwise rotation, slow to fast
	48		Head 5 Dimmer	000 ⇄ 255	0–100%
	49		Head 5 Red	000 ⇄ 255	RGBW mode: 0–100% / CMY mode: 100%–0
	50		Head 5 Green	000 ⇄ 255	RGBW mode: 0–100% / CMY mode: 100%–0
	51		Head 5 Blue	000 ⇄ 255	RGBW mode: 0–100% / CMY mode: 100%–0
	52		Head 5 White	000 ⇄ 255	RGBW mode: 0–100% / CMY mode: 100%–0

Tour (47-channel)		Channel	Function	Value	Percent/Settings
	1		Pan	000 ⇄ 255	0–100%
	2		Fine Pan	000 ⇄ 255	0–100%
	3		Continuous Pan	000	No function
				001 ⇄ 127	Counterclockwise rotation, slow to fast
				128	Stop
				129 ⇄ 255	Clockwise rotation, slow to fast
	4		Tilt Macro	000 ⇄ 047	No function
				048 ⇄ 055	Tilt Macro 1
				056 ⇄ 063	Tilt Macro 2
				064 ⇄ 071	Tilt Macro 3
				072 ⇄ 079	Tilt Macro 4
				080 ⇄ 087	Tilt Macro 5
				088 ⇄ 095	Tilt Macro 6
				096 ⇄ 103	Tilt Macro 7
				104 ⇄ 111	Tilt Macro 8
				112 ⇄ 119	Tilt Macro 9
				120 ⇄ 127	Tilt Macro 10
				128 ⇄ 135	Tilt Macro 11
				136 ⇄ 143	Tilt Macro 12
				144 ⇄ 151	Tilt Macro 13
				152 ⇄ 159	Tilt Macro 14
				160 ⇄ 167	Tilt Macro 15
				168 ⇄ 175	Tilt Macro 16
				176 ⇄ 183	Tilt Macro 17
				184 ⇄ 191	Tilt Macro 18
				192 ⇄ 199	Tilt Macro 19
				200 ⇄ 207	Tilt Macro 20
				208 ⇄ 215	Tilt Macro 21
				216 ⇄ 223	Tilt Macro 22
				224 ⇄ 231	Tilt Macro 23
				232 ⇄ 239	Tilt Macro 24
				240 ⇄ 247	Tilt Macro 25
	248 ⇄ 255	Tilt Macro 26			
	5		Tilt Macro Speed	000 ⇄ 255	Fast to slow

Tour (47-channel cont.)	Channel	Function	Value	Percent/Settings
6	Control		000 ⇄ 009	No function
			010 ⇄ 014	Manual tilt blackout
			015 ⇄ 019	Cancel manual tilt blackout
			020 ⇄ 024	1 fixture macro
			025 ⇄ 029	2 fixture macro 1
			030 ⇄ 034	2 fixture macro 2
			035 ⇄ 039	4 fixture macro 1
			040 ⇄ 044	4 fixture macro 2
			045 ⇄ 049	4 fixture macro 3
			050 ⇄ 054	4 fixture macro 4
			055 ⇄ 059	Pan reset
			060 ⇄ 064	Tilt reset
			065 ⇄ 069	No function (reserved for future use)
			070 ⇄ 074	Reset all
			075 ⇄ 079	No function (reserved for future use)
			080 ⇄ 084	Pan/Tilt reverse
			085 ⇄ 089	Pan reverse
			090 ⇄ 094	Tilt reverse
			095 ⇄ 099	Cancel pan reverse
			100 ⇄ 104	Cancel tilt reverse
			105 ⇄ 109	Cancel pan/tilt reverse
			110 ⇄ 114	No function (reserved for future use)
			115 ⇄ 119	Link all heads to head 1
			120 ⇄ 124	Unlink all heads from head 1
	125 ⇄ 134	No function (reserved for future use)		
	135 ⇄ 139	Dimmer speed mode fast		
	140 ⇄ 144	Dimmer speed mode smooth		
	145 ⇄ 255	No function		
7	Dimmer		000 ⇄ 255	0–100%
8	Shutter		000 ⇄ 019	Off
			020 ⇄ 024	On
			025 ⇄ 064	Strobe 1, fast to slow
			065 ⇄ 069	On
			070 ⇄ 084	Strobe 2 (Fast on, slow off), fast to slow
			085 ⇄ 089	On
			090 ⇄ 104	Strobe 3 (Slow on, fast off), fast to slow
			104 ⇄ 109	On
			110 ⇄ 124	Strobe 4 (Random), fast to slow
			125 ⇄ 129	On
			130 ⇄ 144	Strobe 5 (Random fast on, slow off), fast to slow
			145 ⇄ 149	On
			150 ⇄ 164	Strobe 6 (Random slow on, fast off), fast to slow
			165 ⇄ 169	On
			170 ⇄ 184	Strobe 7 (Pulse), fast to slow
			185 ⇄ 189	On
			190 ⇄ 204	Strobe 8 (Random pulse), fast to slow
			205 ⇄ 209	On
			210 ⇄ 224	Strobe 9 (Fade in, fade out), fast to slow
			225 ⇄ 229	On
	230 ⇄ 244	Strobe 10 (Random pulse), fast to slow		
	245 ⇄ 255	On		

# Operation



Tour	Channel	Function	Value	Percent/Settings
(47-channel cont.)	9	Color Macro	000 ⇔ 013	No function
			014 ⇔ 020	Color 1
			021 ⇔ 028	Color 2
			029 ⇔ 036	Color 3
			037 ⇔ 044	Color 4
			045 ⇔ 052	Color 5
			053 ⇔ 060	Color 6
			061 ⇔ 068	Color 7
			069 ⇔ 076	Color 8
			077 ⇔ 084	Color 9
			085 ⇔ 092	Color 10
			093 ⇔ 100	Color 11
			101 ⇔ 108	Color 12
			109 ⇔ 116	Color 13
			117 ⇔ 124	Color 14
			125 ⇔ 133	Color 15
			134 ⇔ 185	No function
			186 ⇔ 207	Rainbow effect, fast to slow
			208 ⇔ 213	Stop
			214 ⇔ 235	Reverse Rainbow effect, fast to slow
			236 ⇔ 240	No function
			241 ⇔ 255	Color jump, fast to slow

Tour (47-channel cont.)	Channel	Function	Value	Percent/Settings				
				Head 1	Head 2	Head 3	Head 4	Head 5
			000 ⇄ 005	●	●	●	●	●
			006 ⇄ 011	○	●	●	●	●
			012 ⇄ 017	○	○	●	●	●
			018 ⇄ 023	○	○	○	●	●
			024 ⇄ 029	○	○	○	○	●
			030 ⇄ 035	○	○	○	○	○
			036 ⇄ 041	●	○	○	○	○
			042 ⇄ 047	●	●	○	○	○
			048 ⇄ 053	●	●	●	○	○
			054 ⇄ 059	●	●	●	●	○
			060 ⇄ 065	●	●	●	●	●
			066 ⇄ 071	○	○	○	○	○
			072 ⇄ 077	●	○	○	○	○
			078 ⇄ 083	○	●	○	○	○
			084 ⇄ 089	○	○	●	○	○
			090 ⇄ 095	○	○	○	●	○
			096 ⇄ 101	○	○	○	○	●
			102 ⇄ 107	○	○	○	○	○
			108 ⇄ 113	●	●	○	○	○
			114 ⇄ 119	○	●	●	○	○
	10	On/Off Preset (● = on; ○ = off)	120 ⇄ 125	○	○	●	●	○
			126 ⇄ 131	○	○	○	●	●
			132 ⇄ 137	●	○	○	○	●
			138 ⇄ 143	○	○	○	○	○
			144 ⇄ 149	○	●	●	●	●
			150 ⇄ 155	●	○	●	●	●
			156 ⇄ 161	●	●	○	●	●
			162 ⇄ 167	●	●	●	○	●
			168 ⇄ 173	●	●	●	●	○
			174 ⇄ 179	○	○	○	○	○
			180 ⇄ 185	○	○	○	○	●
			186 ⇄ 191	○	○	○	●	●
			192 ⇄ 197	○	○	●	●	●
			198 ⇄ 203	○	●	●	●	●
			204 ⇄ 209	●	●	●	●	●
			210 ⇄ 215	○	○	○	○	○
			216 ⇄ 221	●	●	●	○	○
			222 ⇄ 227	○	●	●	●	○
			228 ⇄ 233	○	○	●	●	●
			234 ⇄ 239	●	○	○	●	●
			240 ⇄ 245	●	●	○	○	●
			246 ⇄ 255	●	●	●	●	●

Tour (47-channel cont.)	Channel	Function	Value	Percent/Settings
			000 ⇔ 015	No function
			016 ⇔ 020	LED Macro 1
			021 ⇔ 025	LED Macro 2
			026 ⇔ 030	LED Macro 3
			031 ⇔ 035	LED Macro 4
			036 ⇔ 040	LED Macro 5
			041 ⇔ 045	LED Macro 6
			046 ⇔ 050	LED Macro 7
			051 ⇔ 055	LED Macro 8
			056 ⇔ 060	LED Macro 9
			061 ⇔ 065	LED Macro 10
			066 ⇔ 070	LED Macro 11
			071 ⇔ 075	LED Macro 12
			076 ⇔ 080	LED Macro 13
			081 ⇔ 085	LED Macro 14
			086 ⇔ 090	LED Macro 15
			091 ⇔ 095	LED Macro 16
			096 ⇔ 100	LED Macro 17
			101 ⇔ 105	LED Macro 18
			106 ⇔ 110	LED Macro 19
			111 ⇔ 115	LED Macro 20
			116 ⇔ 120	LED Macro 21
			121 ⇔ 125	LED Macro 22
			126 ⇔ 130	LED Macro 23
	11	LED Macro/ Auto Program	131 ⇔ 135	LED Macro 24 (cycle 1–23)
			136 ⇔ 140	Auto program 1
			141 ⇔ 145	Auto program 2
			146 ⇔ 150	Auto program 3
			151 ⇔ 155	Auto program 4
			156 ⇔ 160	Auto program 5
			161 ⇔ 165	Auto program 6
			166 ⇔ 170	Auto program 7
			171 ⇔ 175	Auto program 8
			176 ⇔ 180	Auto program 9
			181 ⇔ 185	Auto program 10
			186 ⇔ 190	Auto program 11
			191 ⇔ 195	Auto program 12
			196 ⇔ 200	Auto program 13
			201 ⇔ 205	Auto program 14
			206 ⇔ 210	Auto program 15
			211 ⇔ 215	Auto program 16
			216 ⇔ 220	Auto program 17
			221 ⇔ 225	Auto program 18
			226 ⇔ 230	Auto program 19
			231 ⇔ 235	Auto program 20
			236 ⇔ 240	Auto program 21
			241 ⇔ 245	Auto program 22
			246 ⇔ 250	Auto program 23
			251 ⇔ 255	Auto program 24 (cycle 1–23)
	12	LED Macro Speed	000 ⇔ 255	Slow to fast

Tour	Channel	Function	Value	Percent/Settings
(47-channel cont.)	13	Tilt 1	000 ⇄ 255	0–100%
	14	Fine Tilt 1	000 ⇄ 255	0–100%
	15	Continuous Tilt 1	000	No function
			001 ⇄ 127	Counterclockwise rotation, slow to fast
			128	Stop
			129 ⇄ 255	Clockwise rotation, slow to fast
	16	Head 1 Red	000 ⇄ 255	RGBW mode: 0–100% / CMY mode: 100%–0
	17	Head 1 Green	000 ⇄ 255	RGBW mode: 0–100% / CMY mode: 100%–0
	18	Head 1 Blue	000 ⇄ 255	RGBW mode: 0–100% / CMY mode: 100%–0
	19	Head 1 White	000 ⇄ 255	RGBW mode: 0–100% / CMY mode: 100%–0
	20	Tilt 2	000 ⇄ 255	0–100%
	21	Fine Tilt 2	000 ⇄ 255	0–100%
	22	Continuous Tilt 2	000	No function
			001 ⇄ 127	Counterclockwise rotation, slow to fast
			128	Stop
			129 ⇄ 255	Clockwise rotation, slow to fast
	23	Head 2 Red	000 ⇄ 255	RGBW mode: 0–100% / CMY mode: 100%–0
	24	Head 2 Green	000 ⇄ 255	RGBW mode: 0–100% / CMY mode: 100%–0
	25	Head 2 Blue	000 ⇄ 255	RGBW mode: 0–100% / CMY mode: 100%–0
	26	Head 2 White	000 ⇄ 255	RGBW mode: 0–100% / CMY mode: 100%–0
	27	Tilt 3	000 ⇄ 255	0–100%
	28	Fine Tilt 3	000 ⇄ 255	0–100%
	29	Continuous Tilt 3	000	No function
			001 ⇄ 127	Counterclockwise rotation, slow to fast
			128	Stop
			129 ⇄ 255	Clockwise rotation, slow to fast
	30	Head 3 Red	000 ⇄ 255	RGBW mode: 0–100% / CMY mode: 100%–0
	31	Head 3 Green	000 ⇄ 255	RGBW mode: 0–100% / CMY mode: 100%–0
	32	Head 3 Blue	000 ⇄ 255	RGBW mode: 0–100% / CMY mode: 100%–0
	33	Head 3 White	000 ⇄ 255	RGBW mode: 0–100% / CMY mode: 100%–0
	34	Tilt 4	000 ⇄ 255	0–100%
	35	Fine Tilt 4	000 ⇄ 255	0–100%
	36	Continuous Tilt 4	000	No function
			001 ⇄ 127	Counterclockwise rotation, slow to fast
			128	Stop
			129 ⇄ 255	Clockwise rotation, slow to fast
	37	Head 4 Red	000 ⇄ 255	RGBW mode: 0–100% / CMY mode: 100%–0
	38	Head 4 Green	000 ⇄ 255	RGBW mode: 0–100% / CMY mode: 100%–0
	39	Head 4 Blue	000 ⇄ 255	RGBW mode: 0–100% / CMY mode: 100%–0
	40	Head 4 White	000 ⇄ 255	RGBW mode: 0–100% / CMY mode: 100%–0
	41	Tilt 5	000 ⇄ 255	0–100%
	42	Fine Tilt 5	000 ⇄ 255	0–100%
	43	Continuous Tilt 5	000	No function
			001 ⇄ 127	Counterclockwise rotation, slow to fast
			128	Stop
			129 ⇄ 255	Clockwise rotation, slow to fast
	44	Head 5 Red	000 ⇄ 255	RGBW mode: 0–100% / CMY mode: 100%–0
45	Head 5 Green	000 ⇄ 255	RGBW mode: 0–100% / CMY mode: 100%–0	
46	Head 5 Blue	000 ⇄ 255	RGBW mode: 0–100% / CMY mode: 100%–0	
47	Head 5 White	000 ⇄ 255	RGBW mode: 0–100% / CMY mode: 100%–0	

## Operation



<b>Advanced Mode (47-channel)</b>	<b>Channel</b>	<b>Function</b>	<b>Value</b>	<b>Percent/Settings</b>
	1	Pan	000 ⇄ 255	0–100%
	2	Fine Pan	000 ⇄ 255	0–100%
	3	Continuous Pan	000	No function
			001 ⇄ 127	Counterclockwise rotation, slow to fast
			128	Stop
			129 ⇄ 255	Clockwise rotation, slow to fast
	4	Tilt 1	000 ⇄ 255	0–100%
	5	Fine Tilt 1	000 ⇄ 255	0–100%
	6	Tilt 2	000 ⇄ 255	0–100%
	7	Fine Tilt 2	000 ⇄ 255	0–100%
	8	Tilt 3	000 ⇄ 255	0–100%
	9	Fine Tilt 3	000 ⇄ 255	0–100%
	10	Tilt 4	000 ⇄ 255	0–100%
	11	Fine Tilt 4	000 ⇄ 255	0–100%
	12	Tilt 5	000 ⇄ 255	0–100%
	13	Fine Tilt 5	000 ⇄ 255	0–100%
	14	Continuous Tilt 1	000	No function
			001 ⇄ 127	Counterclockwise rotation, slow to fast
			128	Stop
			129 ⇄ 255	Clockwise rotation, slow to fast
	15	Continuous Tilt 2	000	No function
			001 ⇄ 127	Counterclockwise rotation, slow to fast
			128	Stop
			129 ⇄ 255	Clockwise rotation, slow to fast
	16	Continuous Tilt 3	000	No function
			001 ⇄ 127	Counterclockwise rotation, slow to fast
			128	Stop
			129 ⇄ 255	Clockwise rotation, slow to fast
	17	Continuous Tilt 4	000	No function
			001 ⇄ 127	Counterclockwise rotation, slow to fast
			128	Stop
			129 ⇄ 255	Clockwise rotation, slow to fast
	18	Continuous Tilt 5	000	No function
			001 ⇄ 127	Counterclockwise rotation, slow to fast
			128	Stop
			129 ⇄ 255	Clockwise rotation, slow to fast



Advanced Mode (47-channel cont.)	Channel	Function	Value	Percent/Settings
	<b>19</b>	<b>Tilt Macro</b>	000 ⇄ 047	No function
			048 ⇄ 055	Tilt Macro 1
			056 ⇄ 063	Tilt Macro 2
			064 ⇄ 071	Tilt Macro 3
			072 ⇄ 079	Tilt Macro 4
			080 ⇄ 087	Tilt Macro 5
			088 ⇄ 095	Tilt Macro 6
			096 ⇄ 103	Tilt Macro 7
			104 ⇄ 111	Tilt Macro 8
			112 ⇄ 119	Tilt Macro 9
			120 ⇄ 127	Tilt Macro 10
			128 ⇄ 135	Tilt Macro 11
			136 ⇄ 143	Tilt Macro 12
			144 ⇄ 151	Tilt Macro 13
			152 ⇄ 159	Tilt Macro 14
			160 ⇄ 167	Tilt Macro 15
			168 ⇄ 175	Tilt Macro 16
			176 ⇄ 183	Tilt Macro 17
			184 ⇄ 191	Tilt Macro 18
			192 ⇄ 199	Tilt Macro 19
			200 ⇄ 207	Tilt Macro 20
			208 ⇄ 215	Tilt Macro 21
			216 ⇄ 223	Tilt Macro 22
			224 ⇄ 231	Tilt Macro 23
			232 ⇄ 239	Tilt Macro 24
			240 ⇄ 247	Tilt Macro 25
	248 ⇄ 255	Tilt Macro 26		
	<b>20</b>	<b>Tilt Macro Speed</b>	000 ⇄ 255	Fast to slow

Advanced Mode (47-channel cont.)	Channel	Function	Value	Percent/Settings
21	Control		000⇔009	No function
			010⇔014	Manual tilt blackout
			015⇔019	Cancel manual tilt blackout
			020⇔024	1 fixture macro
			025⇔029	2 fixture macro 1
			030⇔034	2 fixture macro 2
			035⇔039	4 fixture macro 1
			040⇔044	4 fixture macro 2
			045⇔049	4 fixture macro 3
			050⇔054	4 fixture macro 4
			055⇔059	Pan reset
			060⇔064	Tilt reset
			065⇔069	No function (reserved for future use)
			070⇔074	Reset all
			075⇔079	No function (reserved for future use)
			080⇔084	Pan/Tilt reverse
			085⇔089	Pan reverse
			090⇔094	Tilt reverse
			095⇔099	Cancel pan reverse
			100⇔104	Cancel tilt reverse
			105⇔109	Cancel pan/tilt reverse
			110⇔114	No function (reserved for future use)
			115⇔119	Link all heads to head 1
			120⇔124	Unlink all heads from head 1
	125⇔134	No function (reserved for future use)		
	135⇔139	Dimmer speed mode fast		
	140⇔144	Dimmer speed mode smooth		
	145⇔255	No function		
22	Dimmer		000⇔255	0–100%
23	Shutter		000⇔019	Off
			020⇔024	On
			025⇔064	Strobe 1, fast to slow
			065⇔069	On
			070⇔084	Strobe 2 (Fast on, slow off), fast to slow
			085⇔089	On
			090⇔104	Strobe 3 (Slow on, fast off), fast to slow
			104⇔109	On
			110⇔124	Strobe 4 (Random), fast to slow
			125⇔129	On
			130⇔144	Strobe 5 (Random fast on, slow off), fast to slow
			145⇔149	On
			150⇔164	Strobe 6 (Random slow on, fast off), fast to slow
			165⇔169	On
			170⇔184	Strobe 7 (Pulse), fast to slow
			185⇔189	On
			190⇔204	Strobe 8 (Random pulse), fast to slow
			205⇔209	On
			210⇔224	Strobe 9 (Fade in, fade out), fast to slow
			225⇔229	On
	230⇔244	Strobe 10 (Random pulse), fast to slow		
	245⇔255	On		

Advanced Mode (47-channel cont.)	Channel	Function	Value	Percent/Settings
			000 ⇔ 013	No function
			014 ⇔ 020	Color 1
			021 ⇔ 028	Color 2
			029 ⇔ 036	Color 3
			037 ⇔ 044	Color 4
			045 ⇔ 052	Color 5
			053 ⇔ 060	Color 6
			061 ⇔ 068	Color 7
			069 ⇔ 076	Color 8
			077 ⇔ 084	Color 9
			085 ⇔ 092	Color 10
			093 ⇔ 100	Color 11
			101 ⇔ 108	Color 12
			109 ⇔ 116	Color 13
			117 ⇔ 124	Color 14
			125 ⇔ 133	Color 15
			134 ⇔ 185	No function
			186 ⇔ 207	Rainbow effect, fast to slow
			208 ⇔ 213	Stop
			214 ⇔ 235	Reverse Rainbow effect, fast to slow
			236 ⇔ 240	No function
			241 ⇔ 255	Color jump, fast to slow

Advanced Mode (47-channel cont.)	Channel	Function	Value	Percent/Settings				
				Head 1	Head 2	Head 3	Head 4	Head 5
			000 ⇔ 005	●	●	●	●	●
			006 ⇔ 011	○	●	●	●	●
			012 ⇔ 017	○	○	●	●	●
			018 ⇔ 023	○	○	○	●	●
			024 ⇔ 029	○	○	○	○	●
			030 ⇔ 035	○	○	○	○	○
			036 ⇔ 041	●	○	○	○	○
			042 ⇔ 047	●	●	○	○	○
			048 ⇔ 053	●	●	●	○	○
			054 ⇔ 059	●	●	●	●	○
			060 ⇔ 065	●	●	●	●	●
			066 ⇔ 071	○	○	○	○	○
			072 ⇔ 077	●	○	○	○	○
			078 ⇔ 083	○	●	○	○	○
			084 ⇔ 089	○	○	●	○	○
			090 ⇔ 095	○	○	○	●	○
			096 ⇔ 101	○	○	○	○	●
			102 ⇔ 107	○	○	○	○	○
			108 ⇔ 113	●	●	○	○	○
			114 ⇔ 119	○	●	●	○	○
			120 ⇔ 125	○	○	●	●	○
			126 ⇔ 131	○	○	○	●	●
			132 ⇔ 137	●	○	○	○	●
			138 ⇔ 143	○	○	○	○	○
			144 ⇔ 149	○	●	●	●	●
			150 ⇔ 155	●	○	●	●	●
			156 ⇔ 161	●	●	○	●	●
			162 ⇔ 167	●	●	●	○	●
			168 ⇔ 173	●	●	●	●	○
			174 ⇔ 179	○	○	○	○	○
			180 ⇔ 185	○	○	○	○	●
			186 ⇔ 191	○	○	○	●	●
			192 ⇔ 197	○	○	●	●	●
			198 ⇔ 203	○	●	●	●	●
			204 ⇔ 209	●	●	●	●	●
			210 ⇔ 215	○	○	○	○	○
			216 ⇔ 221	●	●	●	○	○
			222 ⇔ 227	○	●	●	●	○
			228 ⇔ 233	○	○	●	●	●
			234 ⇔ 239	●	○	○	●	●
			240 ⇔ 245	●	●	○	○	●
			246 ⇔ 255	●	●	●	●	●

25

**On/Off Preset**  
(● = on; ○ = off)

Advanced Mode (47-channel cont.)	Channel	Function	Value	Percent/Settings
			000 ⇄ 015	No function
			016 ⇄ 020	LED Macro 1
			021 ⇄ 025	LED Macro 2
			026 ⇄ 030	LED Macro 3
			031 ⇄ 035	LED Macro 4
			036 ⇄ 040	LED Macro 5
			041 ⇄ 045	LED Macro 6
			046 ⇄ 050	LED Macro 7
			051 ⇄ 055	LED Macro 8
			056 ⇄ 060	LED Macro 9
			061 ⇄ 065	LED Macro 10
			066 ⇄ 070	LED Macro 11
			071 ⇄ 075	LED Macro 12
			076 ⇄ 080	LED Macro 13
			081 ⇄ 085	LED Macro 14
			086 ⇄ 090	LED Macro 15
			091 ⇄ 095	LED Macro 16
			096 ⇄ 100	LED Macro 17
			101 ⇄ 105	LED Macro 18
			106 ⇄ 110	LED Macro 19
			111 ⇄ 115	LED Macro 20
			116 ⇄ 120	LED Macro 21
			121 ⇄ 125	LED Macro 22
			126 ⇄ 130	LED Macro 23
	26	LED Macro/ Auto Program	131 ⇄ 135	LED Macro 24 (cycle 1–23)
			136 ⇄ 140	Auto program 1
			141 ⇄ 145	Auto program 2
			146 ⇄ 150	Auto program 3
			151 ⇄ 155	Auto program 4
			156 ⇄ 160	Auto program 5
			161 ⇄ 165	Auto program 6
			166 ⇄ 170	Auto program 7
			171 ⇄ 175	Auto program 8
			176 ⇄ 180	Auto program 9
			181 ⇄ 185	Auto program 10
			186 ⇄ 190	Auto program 11
			191 ⇄ 195	Auto program 12
			196 ⇄ 200	Auto program 13
			201 ⇄ 205	Auto program 14
			206 ⇄ 210	Auto program 15
			211 ⇄ 215	Auto program 16
			216 ⇄ 220	Auto program 17
			221 ⇄ 225	Auto program 18
			226 ⇄ 230	Auto program 19
			231 ⇄ 235	Auto program 20
			236 ⇄ 240	Auto program 21
			241 ⇄ 245	Auto program 22
			246 ⇄ 250	Auto program 23
			251 ⇄ 255	Auto program 24 (cycle 1–23)
	27	LED Macro Speed	000 ⇄ 255	Slow to fast

## Operation



<b>Advanced Mode</b> (47-channel cont.)	<b>Channel</b>	<b>Function</b>	<b>Value</b>	<b>Percent/Settings</b>
	28	Head 1 Red	000 ⇄ 255	RGBW mode: 0–100% / CMY mode: 100%–0
	29	Head 1 Green	000 ⇄ 255	RGBW mode: 0–100% / CMY mode: 100%–0
	30	Head 1 Blue	000 ⇄ 255	RGBW mode: 0–100% / CMY mode: 100%–0
	31	Head 1 White	000 ⇄ 255	RGBW mode: 0–100% / CMY mode: 100%–0
	32	Head 2 Red	000 ⇄ 255	RGBW mode: 0–100% / CMY mode: 100%–0
	33	Head 2 Green	000 ⇄ 255	RGBW mode: 0–100% / CMY mode: 100%–0
	34	Head 2 Blue	000 ⇄ 255	RGBW mode: 0–100% / CMY mode: 100%–0
	35	Head 2 White	000 ⇄ 255	RGBW mode: 0–100% / CMY mode: 100%–0
	36	Head 3 Red	000 ⇄ 255	RGBW mode: 0–100% / CMY mode: 100%–0
	37	Head 3 Green	000 ⇄ 255	RGBW mode: 0–100% / CMY mode: 100%–0
	38	Head 3 Blue	000 ⇄ 255	RGBW mode: 0–100% / CMY mode: 100%–0
	39	Head 3 White	000 ⇄ 255	RGBW mode: 0–100% / CMY mode: 100%–0
	40	Head 4 Red	000 ⇄ 255	RGBW mode: 0–100% / CMY mode: 100%–0
	41	Head 4 Green	000 ⇄ 255	RGBW mode: 0–100% / CMY mode: 100%–0
	42	Head 4 Blue	000 ⇄ 255	RGBW mode: 0–100% / CMY mode: 100%–0
	43	Head 4 White	000 ⇄ 255	RGBW mode: 0–100% / CMY mode: 100%–0
	44	Head 5 Red	000 ⇄ 255	RGBW mode: 0–100% / CMY mode: 100%–0
	45	Head 5 Green	000 ⇄ 255	RGBW mode: 0–100% / CMY mode: 100%–0
	46	Head 5 Blue	000 ⇄ 255	RGBW mode: 0–100% / CMY mode: 100%–0
	47	Head 5 White	000 ⇄ 255	RGBW mode: 0–100% / CMY mode: 100%–0

<b>Standard Mode</b> (25-channel)	<b>Channel</b>	<b>Function</b>	<b>Value</b>	<b>Percent/Settings</b>
	1	Pan	000 ⇄ 255	0–100%
	2	Continuous Pan	000	No function
			001 ⇄ 127	Counterclockwise rotation, slow to fast
			128	Stop
			129 ⇄ 255	Clockwise rotation, slow to fast
	3	Tilt 1	000 ⇄ 255	0–100%
	4	Tilt 2	000 ⇄ 255	0–100%
	5	Tilt 3	000 ⇄ 255	0–100%
	6	Tilt 4	000 ⇄ 255	0–100%
	7	Tilt 5	000 ⇄ 255	0–100%
	8	Continuous Tilt 1	000	No function
			001 ⇄ 127	Counterclockwise rotation, slow to fast
			128	Stop
			129 ⇄ 255	Clockwise rotation, slow to fast
	9	Continuous Tilt 2	000	No function
			001 ⇄ 127	Counterclockwise rotation, slow to fast
			128	Stop
			129 ⇄ 255	Clockwise rotation, slow to fast
	10	Continuous Tilt 3	000	No function
			001 ⇄ 127	Counterclockwise rotation, slow to fast
			128	Stop
			129 ⇄ 255	Clockwise rotation, slow to fast
	11	Continuous Tilt 4	000	No function
			001 ⇄ 127	Counterclockwise rotation, slow to fast
			128	Stop
			129 ⇄ 255	Clockwise rotation, slow to fast
	12	Continuous Tilt 5	000	No function
			001 ⇄ 127	Counterclockwise rotation, slow to fast
			128	Stop
			129 ⇄ 255	Clockwise rotation, slow to fast

Standard Mode (25-channel cont.)	Channel	Function	Value	Percent/Settings
	13	Tilt Macro	000 ⇄ 047	No function
			048 ⇄ 055	Tilt Macro 1
			056 ⇄ 063	Tilt Macro 2
			064 ⇄ 071	Tilt Macro 3
			072 ⇄ 079	Tilt Macro 4
			080 ⇄ 087	Tilt Macro 5
			088 ⇄ 095	Tilt Macro 6
			096 ⇄ 103	Tilt Macro 7
			104 ⇄ 111	Tilt Macro 8
			112 ⇄ 119	Tilt Macro 9
			120 ⇄ 127	Tilt Macro 10
			128 ⇄ 135	Tilt Macro 11
			136 ⇄ 143	Tilt Macro 12
			144 ⇄ 151	Tilt Macro 13
			152 ⇄ 159	Tilt Macro 14
			160 ⇄ 167	Tilt Macro 15
			168 ⇄ 175	Tilt Macro 16
			176 ⇄ 183	Tilt Macro 17
			184 ⇄ 191	Tilt Macro 18
			192 ⇄ 199	Tilt Macro 19
			200 ⇄ 207	Tilt Macro 20
			208 ⇄ 215	Tilt Macro 21
			216 ⇄ 223	Tilt Macro 22
			224 ⇄ 231	Tilt Macro 23
			232 ⇄ 239	Tilt Macro 24
			240 ⇄ 247	Tilt Macro 25
248 ⇄ 255	Tilt Macro 26			
	14	Tilt Macro Speed	000 ⇄ 255	Fast to slow

Standard Mode (25-channel cont.)	Channel	Function	Value	Percent/Settings
15	Control		000 ⇄ 009	No function
			010 ⇄ 014	Manual tilt blackout
			015 ⇄ 019	Cancel manual tilt blackout
			020 ⇄ 024	1 fixture macro
			025 ⇄ 029	2 fixture macro 1
			030 ⇄ 034	2 fixture macro 2
			035 ⇄ 039	4 fixture macro 1
			040 ⇄ 044	4 fixture macro 2
			045 ⇄ 049	4 fixture macro 3
			050 ⇄ 054	4 fixture macro 4
			055 ⇄ 059	Pan reset
			060 ⇄ 064	Tilt reset
			065 ⇄ 069	No function (reserved for future use)
			070 ⇄ 074	Reset all
			075 ⇄ 079	No function (reserved for future use)
			080 ⇄ 084	Pan/Tilt reverse
			085 ⇄ 089	Pan reverse
			090 ⇄ 094	Tilt reverse
			095 ⇄ 099	Cancel pan reverse
			100 ⇄ 104	Cancel tilt reverse
			105 ⇄ 109	Cancel pan/tilt reverse
			110 ⇄ 114	No function (reserved for future use)
			115 ⇄ 119	Link all heads to head 1
			120 ⇄ 124	Unlink all heads from head 1
	125 ⇄ 134	No function (reserved for future use)		
	135 ⇄ 139	Dimmer speed mode fast		
	140 ⇄ 144	Dimmer speed mode smooth		
	145 ⇄ 255	No function		
16	Dimmer		000 ⇄ 255	0–100%
17	Shutter		000 ⇄ 019	Off
			020 ⇄ 024	On
			025 ⇄ 064	Strobe 1, fast to slow
			065 ⇄ 069	On
			070 ⇄ 084	Strobe 2 (Fast on, slow off), fast to slow
			085 ⇄ 089	On
			090 ⇄ 104	Strobe 3 (Slow on, fast off), fast to slow
			104 ⇄ 109	On
			110 ⇄ 124	Strobe 4 (Random), fast to slow
			125 ⇄ 129	On
			130 ⇄ 144	Strobe 5 (Random fast on, slow off), fast to slow
			145 ⇄ 149	On
			150 ⇄ 164	Strobe 6 (Random slow on, fast off), fast to slow
			165 ⇄ 169	On
			170 ⇄ 184	Strobe 7 (Pulse), fast to slow
			185 ⇄ 189	On
			190 ⇄ 204	Strobe 8 (Random pulse), fast to slow
			205 ⇄ 209	On
			210 ⇄ 224	Strobe 9 (Fade in, fade out), fast to slow
			225 ⇄ 229	On
	230 ⇄ 244	Strobe 10 (Random pulse), fast to slow		
	245 ⇄ 255	On		



Standard Mode (25-channel cont.)	Channel	Function	Value	Percent/Settings
			000 ⇔ 013	No function
			014 ⇔ 020	Color 1
			021 ⇔ 028	Color 2
			029 ⇔ 036	Color 3
			037 ⇔ 044	Color 4
			045 ⇔ 052	Color 5
			053 ⇔ 060	Color 6
			061 ⇔ 068	Color 7
			069 ⇔ 076	Color 8
			077 ⇔ 084	Color 9
			085 ⇔ 092	Color 10
			093 ⇔ 100	Color 11
			101 ⇔ 108	Color 12
			109 ⇔ 116	Color 13
			117 ⇔ 124	Color 14
			125 ⇔ 133	Color 15
			134 ⇔ 185	No function
			186 ⇔ 207	Rainbow effect, fast to slow
			208 ⇔ 213	Stop
			214 ⇔ 235	Reverse Rainbow effect, fast to slow
			236 ⇔ 240	No function
			241 ⇔ 255	Color jump, fast to slow

Standard Mode (25-channel cont.)	Channel	Function	Value	Percent/Settings				
				Head 1	Head 2	Head 3	Head 4	Head 5
			000 ⇔ 005	●	●	●	●	●
			006 ⇔ 011	○	●	●	●	●
			012 ⇔ 017	○	○	●	●	●
			018 ⇔ 023	○	○	○	●	●
			024 ⇔ 029	○	○	○	○	●
			030 ⇔ 035	○	○	○	○	○
			036 ⇔ 041	●	○	○	○	○
			042 ⇔ 047	●	●	○	○	○
			048 ⇔ 053	●	●	●	○	○
			054 ⇔ 059	●	●	●	●	○
			060 ⇔ 065	●	●	●	●	●
			066 ⇔ 071	○	○	○	○	○
			072 ⇔ 077	●	○	○	○	○
			078 ⇔ 083	○	●	○	○	○
			084 ⇔ 089	○	○	●	○	○
			090 ⇔ 095	○	○	○	●	○
			096 ⇔ 101	○	○	○	○	●
			102 ⇔ 107	○	○	○	○	○
			108 ⇔ 113	●	●	○	○	○
			114 ⇔ 119	○	●	●	○	○
			120 ⇔ 125	○	○	●	●	○
			126 ⇔ 131	○	○	○	●	●
			132 ⇔ 137	●	○	○	○	●
			138 ⇔ 143	○	○	○	○	○
			144 ⇔ 149	○	●	●	●	●
			150 ⇔ 155	●	○	●	●	●
			156 ⇔ 161	●	●	○	●	●
			162 ⇔ 167	●	●	●	○	●
			168 ⇔ 173	●	●	●	●	○
			174 ⇔ 179	○	○	○	○	○
			180 ⇔ 185	○	○	○	○	●
			186 ⇔ 191	○	○	○	●	●
			192 ⇔ 197	○	○	●	●	●
			198 ⇔ 203	○	●	●	●	●
			204 ⇔ 209	●	●	●	●	●
			210 ⇔ 215	○	○	○	○	○
			216 ⇔ 221	●	●	●	○	○
			222 ⇔ 227	○	●	●	●	○
			228 ⇔ 233	○	○	●	●	●
			234 ⇔ 239	●	○	○	●	●
			240 ⇔ 245	●	●	○	○	●
			246 ⇔ 255	●	●	●	●	●

19

**On/Off Preset**  
(● = on; ○ = off)

Standard Mode (25-channel cont.)	Channel	Function	Value	Percent/Settings
			000 ⇔ 015	No function
			016 ⇔ 020	LED Macro 1
			021 ⇔ 025	LED Macro 2
			026 ⇔ 030	LED Macro 3
			031 ⇔ 035	LED Macro 4
			036 ⇔ 040	LED Macro 5
			041 ⇔ 045	LED Macro 6
			046 ⇔ 050	LED Macro 7
			051 ⇔ 055	LED Macro 8
			056 ⇔ 060	LED Macro 9
			061 ⇔ 065	LED Macro 10
			066 ⇔ 070	LED Macro 11
			071 ⇔ 075	LED Macro 12
			076 ⇔ 080	LED Macro 13
			081 ⇔ 085	LED Macro 14
			086 ⇔ 090	LED Macro 15
			091 ⇔ 095	LED Macro 16
			096 ⇔ 100	LED Macro 17
			101 ⇔ 105	LED Macro 18
			106 ⇔ 110	LED Macro 19
			111 ⇔ 115	LED Macro 20
			116 ⇔ 120	LED Macro 21
			121 ⇔ 125	LED Macro 22
			126 ⇔ 130	LED Macro 23
	20	LED Macro/ Auto Program	131 ⇔ 135	LED Macro 24 (cycle 1–23)
			136 ⇔ 140	Auto program 1
			141 ⇔ 145	Auto program 2
			146 ⇔ 150	Auto program 3
			151 ⇔ 155	Auto program 4
			156 ⇔ 160	Auto program 5
			161 ⇔ 165	Auto program 6
			166 ⇔ 170	Auto program 7
			171 ⇔ 175	Auto program 8
			176 ⇔ 180	Auto program 9
			181 ⇔ 185	Auto program 10
			186 ⇔ 190	Auto program 11
			191 ⇔ 195	Auto program 12
			196 ⇔ 200	Auto program 13
			201 ⇔ 205	Auto program 14
			206 ⇔ 210	Auto program 15
			211 ⇔ 215	Auto program 16
			216 ⇔ 220	Auto program 17
			221 ⇔ 225	Auto program 18
			226 ⇔ 230	Auto program 19
			231 ⇔ 235	Auto program 20
			236 ⇔ 240	Auto program 21
			241 ⇔ 245	Auto program 22
			246 ⇔ 250	Auto program 23
			251 ⇔ 255	Auto program 24 (cycle 1–23)
	21	LED Macro Speed	000 ⇔ 255	Slow to fast

## Operation



<b>Standard Mode</b> (25-channel cont.)	<b>Channel</b>	<b>Function</b>	<b>Value</b>	<b>Percent/Settings</b>
	22	Red	000 ⇄ 255	RGBW mode: 0–100% / CMY mode: 100%–0
	23	Green	000 ⇄ 255	RGBW mode: 0–100% / CMY mode: 100%–0
	24	Blue	000 ⇄ 255	RGBW mode: 0–100% / CMY mode: 100%–0
	25	White	000 ⇄ 255	RGBW mode: 0–100% / CMY mode: 100%–0

<b>Basic Mode</b> (18-channel)	<b>Channel</b>	<b>Function</b>	<b>Value</b>	<b>Percent/Settings</b>
	1	Pan	000 ⇄ 255	0–100%
	2	Continuous Pan	000	No function
			001 ⇄ 127	Counterclockwise rotation, slow to fast
			128	Stop
			129 ⇄ 255	Clockwise rotation, slow to fast
	3	Tilt All	000 ⇄ 255	0–100%
	4	Continuous Tilt All	000	No function
			001 ⇄ 127	Counterclockwise rotation, slow to fast
			128	Stop
			129 ⇄ 255	Clockwise rotation, slow to fast
	5	Tilt Offset	000 ⇄ 255	Offset heads from each other, 0–360°
	6	Tilt Macro	000 ⇄ 047	No function
			048 ⇄ 055	Tilt Macro 1
			056 ⇄ 063	Tilt Macro 2
			064 ⇄ 071	Tilt Macro 3
			072 ⇄ 079	Tilt Macro 4
			080 ⇄ 087	Tilt Macro 5
			088 ⇄ 095	Tilt Macro 6
			096 ⇄ 103	Tilt Macro 7
			104 ⇄ 111	Tilt Macro 8
			112 ⇄ 119	Tilt Macro 9
			120 ⇄ 127	Tilt Macro 10
			128 ⇄ 135	Tilt Macro 11
			136 ⇄ 143	Tilt Macro 12
			144 ⇄ 151	Tilt Macro 13
			152 ⇄ 159	Tilt Macro 14
			160 ⇄ 167	Tilt Macro 15
			168 ⇄ 175	Tilt Macro 16
			176 ⇄ 183	Tilt Macro 17
			184 ⇄ 191	Tilt Macro 18
			192 ⇄ 199	Tilt Macro 19
			200 ⇄ 207	Tilt Macro 20
			208 ⇄ 215	Tilt Macro 21
			216 ⇄ 223	Tilt Macro 22
			224 ⇄ 231	Tilt Macro 23
			232 ⇄ 239	Tilt Macro 24
			240 ⇄ 247	Tilt Macro 25
	248 ⇄ 255	Tilt Macro 26		
	7	Tilt Macro Speed	000 ⇄ 255	Fast to slow

**Basic Mode**  
 (18-channel cont.)

Channel	Function	Value	Percent/Settings
<b>8</b>	<b>Control</b>	000 ⇄ 009	No function
		010 ⇄ 014	Manual tilt blackout
		015 ⇄ 019	Cancel manual tilt blackout
		020 ⇄ 024	1 fixture macro
		025 ⇄ 029	2 fixture macro 1
		030 ⇄ 034	2 fixture macro 2
		035 ⇄ 039	4 fixture macro 1
		040 ⇄ 044	4 fixture macro 2
		045 ⇄ 049	4 fixture macro 3
		050 ⇄ 054	4 fixture macro 4
		055 ⇄ 059	Pan reset
		060 ⇄ 064	Tilt reset
		065 ⇄ 069	No function (reserved for future use)
		070 ⇄ 074	Reset all
		075 ⇄ 079	No function (reserved for future use)
		080 ⇄ 084	Pan/Tilt reverse
		085 ⇄ 089	Pan reverse
		090 ⇄ 094	Tilt reverse
		095 ⇄ 099	Cancel pan reverse
		100 ⇄ 104	Cancel tilt reverse
		105 ⇄ 109	Cancel pan/tilt reverse
		110 ⇄ 114	No function (reserved for future use)
		115 ⇄ 119	Link all heads to head 1
		120 ⇄ 124	Unlink all heads from head 1
125 ⇄ 134	No function (reserved for future use)		
135 ⇄ 139	Dimmer speed mode fast		
140 ⇄ 144	Dimmer speed mode smooth		
145 ⇄ 255	No function		
<b>9</b>	<b>Dimmer</b>	000 ⇄ 255	0–100%
<b>10</b>	<b>Shutter</b>	000 ⇄ 019	Off
		020 ⇄ 024	On
		025 ⇄ 064	Strobe 1, fast to slow
		065 ⇄ 069	On
		070 ⇄ 084	Strobe 2 (Fast on, slow off), fast to slow
		085 ⇄ 089	On
		090 ⇄ 104	Strobe 3 (Slow on, fast off), fast to slow
		104 ⇄ 109	On
		110 ⇄ 124	Strobe 4 (Random), fast to slow
		125 ⇄ 129	On
		130 ⇄ 144	Strobe 5 (Random fast on, slow off), fast to slow
		145 ⇄ 149	On
		150 ⇄ 164	Strobe 6 (Random slow on, fast off), fast to slow
		165 ⇄ 169	On
		170 ⇄ 184	Strobe 7 (Pulse), fast to slow
		185 ⇄ 189	On
		190 ⇄ 204	Strobe 8 (Random pulse), fast to slow
		205 ⇄ 209	On
		210 ⇄ 224	Strobe 9 (Fade in, fade out), fast to slow
		225 ⇄ 229	On
		230 ⇄ 244	Strobe 10 (Random pulse), fast to slow
245 ⇄ 255	On		

## Operation



Basic Mode (18-channel cont.)	Channel	Function	Value	Percent/Settings
			000 ⇔ 013	No function
			014 ⇔ 020	Color 1
			021 ⇔ 028	Color 2
			029 ⇔ 036	Color 3
			037 ⇔ 044	Color 4
			045 ⇔ 052	Color 5
			053 ⇔ 060	Color 6
			061 ⇔ 068	Color 7
			069 ⇔ 076	Color 8
			077 ⇔ 084	Color 9
			085 ⇔ 092	Color 10
			093 ⇔ 100	Color 11
			101 ⇔ 108	Color 12
			109 ⇔ 116	Color 13
			117 ⇔ 124	Color 14
			125 ⇔ 133	Color 15
			134 ⇔ 185	No function
			186 ⇔ 207	Rainbow effect, fast to slow
			208 ⇔ 213	Stop
			214 ⇔ 235	Reverse Rainbow effect, fast to slow
			236 ⇔ 240	No function
			241 ⇔ 255	Color jump, fast to slow

Basic Mode (18-channel cont.)	Channel	Function	Value	Percent/Settings				
				Head 1	Head 2	Head 3	Head 4	Head 5
			000 ⇔ 005	●	●	●	●	●
			006 ⇔ 011	○	●	●	●	●
			012 ⇔ 017	○	○	●	●	●
			018 ⇔ 023	○	○	○	●	●
			024 ⇔ 029	○	○	○	○	●
			030 ⇔ 035	○	○	○	○	○
			036 ⇔ 041	●	○	○	○	○
			042 ⇔ 047	●	●	○	○	○
			048 ⇔ 053	●	●	●	○	○
			054 ⇔ 059	●	●	●	●	○
			060 ⇔ 065	●	●	●	●	●
			066 ⇔ 071	○	○	○	○	○
			072 ⇔ 077	●	○	○	○	○
			078 ⇔ 083	○	●	○	○	○
			084 ⇔ 089	○	○	●	○	○
			090 ⇔ 095	○	○	○	●	○
			096 ⇔ 101	○	○	○	○	●
			102 ⇔ 107	○	○	○	○	○
			108 ⇔ 113	●	●	○	○	○
			114 ⇔ 119	○	●	●	○	○
	12	<b>On/Off Preset</b> (● = on; ○ = off)	120 ⇔ 125	○	○	●	●	○
			126 ⇔ 131	○	○	○	●	●
			132 ⇔ 137	●	○	○	○	●
			138 ⇔ 143	○	○	○	○	○
			144 ⇔ 149	○	●	●	●	●
			150 ⇔ 155	●	○	●	●	●
			156 ⇔ 161	●	●	○	●	●
			162 ⇔ 167	●	●	●	○	●
			168 ⇔ 173	●	●	●	●	○
			174 ⇔ 179	○	○	○	○	○
			180 ⇔ 185	○	○	○	○	●
			186 ⇔ 191	○	○	○	●	●
			192 ⇔ 197	○	○	●	●	●
			198 ⇔ 203	○	●	●	●	●
			204 ⇔ 209	●	●	●	●	●
			210 ⇔ 215	○	○	○	○	○
			216 ⇔ 221	●	●	●	○	○
			222 ⇔ 227	○	●	●	●	○
			228 ⇔ 233	○	○	●	●	●
			234 ⇔ 239	●	○	○	●	●
			240 ⇔ 245	●	●	○	○	●
			246 ⇔ 255	●	●	●	●	●

# Operation



Basic Mode (18-channel cont.)	Channel	Function	Value	Percent/Settings
			000 ⇔ 015	No function
			016 ⇔ 020	LED Macro 1
			021 ⇔ 025	LED Macro 2
			026 ⇔ 030	LED Macro 3
			031 ⇔ 035	LED Macro 4
			036 ⇔ 040	LED Macro 5
			041 ⇔ 045	LED Macro 6
			046 ⇔ 050	LED Macro 7
			051 ⇔ 055	LED Macro 8
			056 ⇔ 060	LED Macro 9
			061 ⇔ 065	LED Macro 10
			066 ⇔ 070	LED Macro 11
			071 ⇔ 075	LED Macro 12
			076 ⇔ 080	LED Macro 13
			081 ⇔ 085	LED Macro 14
			086 ⇔ 090	LED Macro 15
			091 ⇔ 095	LED Macro 16
			096 ⇔ 100	LED Macro 17
			101 ⇔ 105	LED Macro 18
			106 ⇔ 110	LED Macro 19
			111 ⇔ 115	LED Macro 20
			116 ⇔ 120	LED Macro 21
			121 ⇔ 125	LED Macro 22
			126 ⇔ 130	LED Macro 23
			131 ⇔ 135	LED Macro 24 (cycle 1–23)
	13	LED Macro/ Auto Program	136 ⇔ 140	Auto program 1
			141 ⇔ 145	Auto program 2
			146 ⇔ 150	Auto program 3
			151 ⇔ 155	Auto program 4
			156 ⇔ 160	Auto program 5
			161 ⇔ 165	Auto program 6
			166 ⇔ 170	Auto program 7
			171 ⇔ 175	Auto program 8
			176 ⇔ 180	Auto program 9
			181 ⇔ 185	Auto program 10
			186 ⇔ 190	Auto program 11
			191 ⇔ 195	Auto program 12
			196 ⇔ 200	Auto program 13
			201 ⇔ 205	Auto program 14
			206 ⇔ 210	Auto program 15
			211 ⇔ 215	Auto program 16
			216 ⇔ 220	Auto program 17
			221 ⇔ 225	Auto program 18
			226 ⇔ 230	Auto program 19
			231 ⇔ 235	Auto program 20
			236 ⇔ 240	Auto program 21
			241 ⇔ 245	Auto program 22
			246 ⇔ 250	Auto program 23
			251 ⇔ 255	Auto program 24 (cycle 1–23)
	14	LED Macro Speed	000 ⇔ 255	Slow to fast



<b>Basic Mode</b> (18-channel cont.)	<b>Channel</b>	<b>Function</b>	<b>Value</b>	<b>Percent/Settings</b>
	<b>15</b>	<b>Red</b>	000 ⇄ 255	RGBW mode: 0–100% / CMY mode: 100%–0
	<b>16</b>	<b>Green</b>	000 ⇄ 255	RGBW mode: 0–100% / CMY mode: 100%–0
	<b>17</b>	<b>Blue</b>	000 ⇄ 255	RGBW mode: 0–100% / CMY mode: 100%–0
	<b>18</b>	<b>White</b>	000 ⇄ 255	RGBW mode: 0–100% / CMY mode: 100%–0

### Dual Control Movement Values

<b>Advanced Movement Mode</b> (23-channel)	<b>Channel</b>	<b>Function</b>	<b>Value</b>	<b>Percent/Settings</b>
	<b>1</b>	<b>Pan</b>	000 ⇄ 255	0–100%
	<b>2</b>	<b>Fine Pan</b>	000 ⇄ 255	0–100%
	<b>3</b>	<b>Continuous Pan</b>	000	No function
			001 ⇄ 127	Counterclockwise rotation, slow to fast
			128	Stop
			129 ⇄ 255	Clockwise rotation, slow to fast
	<b>4</b>	<b>Tilt 1</b>	000 ⇄ 255	0–100%
	<b>5</b>	<b>Fine Tilt 1</b>	000 ⇄ 255	0–100%
	<b>6</b>	<b>Tilt 2</b>	000 ⇄ 255	0–100%
	<b>7</b>	<b>Fine Tilt 2</b>	000 ⇄ 255	0–100%
	<b>8</b>	<b>Tilt 3</b>	000 ⇄ 255	0–100%
	<b>9</b>	<b>Fine Tilt 3</b>	000 ⇄ 255	0–100%
	<b>10</b>	<b>Tilt 4</b>	000 ⇄ 255	0–100%
	<b>11</b>	<b>Fine Tilt 4</b>	000 ⇄ 255	0–100%
	<b>12</b>	<b>Tilt 5</b>	000 ⇄ 255	0–100%
	<b>13</b>	<b>Fine Tilt 5</b>	000 ⇄ 255	0–100%
	<b>14</b>	<b>Continuous Tilt 1</b>	000	No function
			001 ⇄ 127	Counterclockwise rotation, slow to fast
			128	Stop
			129 ⇄ 255	Clockwise rotation, slow to fast
	<b>15</b>	<b>Continuous Tilt 2</b>	000	No function
			001 ⇄ 127	Counterclockwise rotation, slow to fast
			128	Stop
			129 ⇄ 255	Clockwise rotation, slow to fast
	<b>16</b>	<b>Continuous Tilt 3</b>	000	No function
			001 ⇄ 127	Counterclockwise rotation, slow to fast
			128	Stop
			129 ⇄ 255	Clockwise rotation, slow to fast
	<b>17</b>	<b>Continuous Tilt 4</b>	000	No function
			001 ⇄ 127	Counterclockwise rotation, slow to fast
			128	Stop
			129 ⇄ 255	Clockwise rotation, slow to fast
	<b>18</b>	<b>Continuous Tilt 5</b>	000	No function
			001 ⇄ 127	Counterclockwise rotation, slow to fast
			128	Stop
			129 ⇄ 255	Clockwise rotation, slow to fast

Advanced Movement Mode (23-channel cont.)	Channel	Function	Value	Percent/Settings
19	Tilt Macro		000 ⇄ 047	No function
			048 ⇄ 055	Tilt Macro 1
			056 ⇄ 063	Tilt Macro 2
			064 ⇄ 071	Tilt Macro 3
			072 ⇄ 079	Tilt Macro 4
			080 ⇄ 087	Tilt Macro 5
			088 ⇄ 095	Tilt Macro 6
			096 ⇄ 103	Tilt Macro 7
			104 ⇄ 111	Tilt Macro 8
			112 ⇄ 119	Tilt Macro 9
			120 ⇄ 127	Tilt Macro 10
			128 ⇄ 135	Tilt Macro 11
			136 ⇄ 143	Tilt Macro 12
			144 ⇄ 151	Tilt Macro 13
			152 ⇄ 159	Tilt Macro 14
			160 ⇄ 167	Tilt Macro 15
			168 ⇄ 175	Tilt Macro 16
			176 ⇄ 183	Tilt Macro 17
			184 ⇄ 191	Tilt Macro 18
			192 ⇄ 199	Tilt Macro 19
			200 ⇄ 207	Tilt Macro 20
			208 ⇄ 215	Tilt Macro 21
			216 ⇄ 223	Tilt Macro 22
			224 ⇄ 231	Tilt Macro 23
			232 ⇄ 239	Tilt Macro 24
			240 ⇄ 247	Tilt Macro 25
			248 ⇄ 255	Tilt Macro 26
20	Tilt Macro Speed		000 ⇄ 255	Fast to slow
21	Dimmer		000 ⇄ 255	0–100%
22	Shutter		000 ⇄ 019	Off
			020 ⇄ 024	On
			025 ⇄ 064	Strobe 1, fast to slow
			065 ⇄ 069	On
			070 ⇄ 084	Strobe 2 (Fast on, slow off), fast to slow
			085 ⇄ 089	On
			090 ⇄ 104	Strobe 3 (Slow on, fast off), fast to slow
			104 ⇄ 109	On
			110 ⇄ 124	Strobe 4 (Random), fast to slow
			125 ⇄ 129	On
			130 ⇄ 144	Strobe 5 (Random fast on, slow off), fast to slow
			145 ⇄ 149	On
			150 ⇄ 164	Strobe 6 (Random slow on, fast off), fast to slow
			165 ⇄ 169	On
			170 ⇄ 184	Strobe 7 (Pulse), fast to slow
			185 ⇄ 189	On
			190 ⇄ 204	Strobe 8 (Random pulse), fast to slow
			205 ⇄ 209	On
			210 ⇄ 224	Strobe 9 (Fade in, fade out), fast to slow
			225 ⇄ 229	On
	230 ⇄ 244	Strobe 10 (Random pulse), fast to slow		
	245 ⇄ 255	On		

**Advanced  
Movement Mode**  
(23-channel cont.)

Channel	Function	Value	Percent/Settings
23	Control	000 ⇄ 009	No function
		010 ⇄ 014	Manual tilt blackout
		015 ⇄ 019	Cancel manual tilt blackout
		020 ⇄ 024	1 fixture macro
		025 ⇄ 029	2 fixture macro 1
		030 ⇄ 034	2 fixture macro 2
		035 ⇄ 039	4 fixture macro 1
		040 ⇄ 044	4 fixture macro 2
		045 ⇄ 049	4 fixture macro 3
		050 ⇄ 054	4 fixture macro 4
		055 ⇄ 059	Pan reset
		060 ⇄ 064	Tilt reset
		065 ⇄ 069	No function (reserved for future use)
		070 ⇄ 074	Reset all
		075 ⇄ 079	No function (reserved for future use)
		080 ⇄ 084	Pan/Tilt reverse
		085 ⇄ 089	Pan reverse
		090 ⇄ 094	Tilt reverse
		095 ⇄ 099	Cancel pan reverse
		100 ⇄ 104	Cancel tilt reverse
		105 ⇄ 109	Cancel pan/tilt reverse
		110 ⇄ 114	No function (reserved for future use)
		115 ⇄ 119	Link all heads to head 1
		120 ⇄ 124	Unlink all heads from head 1
		125 ⇄ 134	No function (reserved for future use)
		135 ⇄ 139	Dimmer speed mode fast
		140 ⇄ 144	Dimmer speed mode smooth
145 ⇄ 255	No function		

## Operation



<b>Standard Movement Mode</b> (17-channel)	<b>Channel</b>	<b>Function</b>	<b>Value</b>	<b>Percent/Settings</b>
	1	Pan	000 ⇄ 255	0–100%
	2	Continuous Pan	000	No function
			001 ⇄ 127	Counterclockwise rotation, slow to fast
			128	Stop
			129 ⇄ 255	Clockwise rotation, slow to fast
	3	Tilt 1	000 ⇄ 255	0–100%
	4	Tilt 2	000 ⇄ 255	0–100%
	5	Tilt 3	000 ⇄ 255	0–100%
	6	Tilt 4	000 ⇄ 255	0–100%
	7	Tilt 5	000 ⇄ 255	0–100%
	8	Continuous Tilt 1	000	No function
			001 ⇄ 127	Counterclockwise rotation, slow to fast
128			Stop	
129 ⇄ 255			Clockwise rotation, slow to fast	
9	Continuous Tilt 2	000	No function	
		001 ⇄ 127	Counterclockwise rotation, slow to fast	
		128	Stop	
		129 ⇄ 255	Clockwise rotation, slow to fast	
10	Continuous Tilt 3	000	No function	
		001 ⇄ 127	Counterclockwise rotation, slow to fast	
		128	Stop	
		129 ⇄ 255	Clockwise rotation, slow to fast	
11	Continuous Tilt 4	000	No function	
		001 ⇄ 127	Counterclockwise rotation, slow to fast	
		128	Stop	
		129 ⇄ 255	Clockwise rotation, slow to fast	
12	Continuous Tilt 5	000	No function	
		001 ⇄ 127	Counterclockwise rotation, slow to fast	
		128	Stop	
		129 ⇄ 255	Clockwise rotation, slow to fast	

Standard Movement Mode (17-channel cont.)	Channel	Function	Value	Percent/Settings
	<b>13</b>	<b>Tilt Macro</b>	000 ⇔ 047	No function
			048 ⇔ 055	Tilt Macro 1
			056 ⇔ 063	Tilt Macro 2
			064 ⇔ 071	Tilt Macro 3
			072 ⇔ 079	Tilt Macro 4
			080 ⇔ 087	Tilt Macro 5
			088 ⇔ 095	Tilt Macro 6
			096 ⇔ 103	Tilt Macro 7
			104 ⇔ 111	Tilt Macro 8
			112 ⇔ 119	Tilt Macro 9
			120 ⇔ 127	Tilt Macro 10
			128 ⇔ 135	Tilt Macro 11
			136 ⇔ 143	Tilt Macro 12
			144 ⇔ 151	Tilt Macro 13
			152 ⇔ 159	Tilt Macro 14
			160 ⇔ 167	Tilt Macro 15
			168 ⇔ 175	Tilt Macro 16
			176 ⇔ 183	Tilt Macro 17
			184 ⇔ 191	Tilt Macro 18
			192 ⇔ 199	Tilt Macro 19
			200 ⇔ 207	Tilt Macro 20
			208 ⇔ 215	Tilt Macro 21
			216 ⇔ 223	Tilt Macro 22
			224 ⇔ 231	Tilt Macro 23
			232 ⇔ 239	Tilt Macro 24
			240 ⇔ 247	Tilt Macro 25
	248 ⇔ 255	Tilt Macro 26		
	<b>14</b>	<b>Tilt Macro Speed</b>	000 ⇔ 255	Fast to slow
	<b>15</b>	<b>Dimmer</b>	000 ⇔ 255	0–100%

## Operation



Standard Movement Mode (17-channel cont.)	Channel	Function	Value	Percent/Settings
16	Shutter		000⇔019	Off
			020⇔024	On
			025⇔064	Strobe 1, fast to slow
			065⇔069	On
			070⇔084	Strobe 2 (Fast on, slow off), fast to slow
			085⇔089	On
			090⇔104	Strobe 3 (Slow on, fast off), fast to slow
			104⇔109	On
			110⇔124	Strobe 4 (Random), fast to slow
			125⇔129	On
			130⇔144	Strobe 5 (Random fast on, slow off), fast to slow
			145⇔149	On
			150⇔164	Strobe 6 (Random slow on, fast off), fast to slow
			165⇔169	On
			170⇔184	Strobe 7 (Pulse), fast to slow
			185⇔189	On
			190⇔204	Strobe 8 (Random pulse), fast to slow
			205⇔209	On
			210⇔224	Strobe 9 (Fade in, fade out), fast to slow
			225⇔229	On
	230⇔244	Strobe 10 (Random pulse), fast to slow		
	245⇔255	On		
17	Control		000⇔009	No function
			010⇔014	Manual tilt blackout
			015⇔019	Cancel manual tilt blackout
			020⇔024	1 fixture macro
			025⇔029	2 fixture macro 1
			030⇔034	2 fixture macro 2
			035⇔039	4 fixture macro 1
			040⇔044	4 fixture macro 2
			045⇔049	4 fixture macro 3
			050⇔054	4 fixture macro 4
			055⇔059	Pan reset
			060⇔064	Tilt reset
			065⇔069	No function (reserved for future use)
			070⇔074	Reset all
			075⇔079	No function (reserved for future use)
			080⇔084	Pan/Tilt reverse
			085⇔089	Pan reverse
			090⇔094	Tilt reverse
			095⇔099	Cancel pan reverse
			100⇔104	Cancel tilt reverse
			105⇔109	Cancel pan/tilt reverse
			110⇔114	No function (reserved for future use)
			115⇔119	Link all heads to head 1
			120⇔124	Unlink all heads from head 1
			125⇔134	No function (reserved for future use)
			135⇔139	Dimmer speed mode fast
	140⇔144	Dimmer speed mode smooth		
	145⇔255	No function		

<b>Basic Movement Mode</b>	<b>Channel</b>	<b>Function</b>	<b>Value</b>	<b>Percent/Settings</b>
<b>(10-channel)</b>	<b>1</b>	<b>Pan</b>	000 ⇄ 255	0–100%
	<b>2</b>	<b>Continuous Pan</b>	000	No function
			001 ⇄ 127	Counterclockwise rotation, slow to fast
			128	Stop
			129 ⇄ 255	Clockwise rotation, slow to fast
	<b>3</b>	<b>Tilt All</b>	000 ⇄ 255	0–100%
	<b>4</b>	<b>Continuous Tilt All</b>	000	No function
			001 ⇄ 127	Counterclockwise rotation, slow to fast
			128	Stop
			129 ⇄ 255	Clockwise rotation, slow to fast
	<b>5</b>	<b>Tilt Offset</b>	000 ⇄ 255	Offset heads from each other, 0–360°
	<b>6</b>	<b>Tilt Macro</b>	000 ⇄ 047	No function
			048 ⇄ 055	Tilt Macro 1
			056 ⇄ 063	Tilt Macro 2
			064 ⇄ 071	Tilt Macro 3
			072 ⇄ 079	Tilt Macro 4
			080 ⇄ 087	Tilt Macro 5
			088 ⇄ 095	Tilt Macro 6
			096 ⇄ 103	Tilt Macro 7
			104 ⇄ 111	Tilt Macro 8
			112 ⇄ 119	Tilt Macro 9
			120 ⇄ 127	Tilt Macro 10
			128 ⇄ 135	Tilt Macro 11
			136 ⇄ 143	Tilt Macro 12
			144 ⇄ 151	Tilt Macro 13
			152 ⇄ 159	Tilt Macro 14
			160 ⇄ 167	Tilt Macro 15
168 ⇄ 175			Tilt Macro 16	
176 ⇄ 183			Tilt Macro 17	
184 ⇄ 191			Tilt Macro 18	
192 ⇄ 199			Tilt Macro 19	
200 ⇄ 207			Tilt Macro 20	
208 ⇄ 215			Tilt Macro 21	
216 ⇄ 223			Tilt Macro 22	
224 ⇄ 231			Tilt Macro 23	
232 ⇄ 239			Tilt Macro 24	
240 ⇄ 247			Tilt Macro 25	
248 ⇄ 255	Tilt Macro 26			
<b>7</b>	<b>Tilt Macro Speed</b>	000 ⇄ 255	Fast to slow	
<b>8</b>	<b>Dimmer</b>	000 ⇄ 255	0–100%	

## Operation



Basic Movement Mode (10-channel cont.)	Channel	Function	Value	Percent/Settings
9	Shutter	000 ⇄ 019	Off	
		020 ⇄ 024	On	
		025 ⇄ 064	Strobe 1, fast to slow	
		065 ⇄ 069	On	
		070 ⇄ 084	Strobe 2 (Fast on, slow off), fast to slow	
		085 ⇄ 089	On	
		090 ⇄ 104	Strobe 3 (Slow on, fast off), fast to slow	
		104 ⇄ 109	On	
		110 ⇄ 124	Strobe 4 (Random), fast to slow	
		125 ⇄ 129	On	
		130 ⇄ 144	Strobe 5 (Random fast on, slow off), fast to slow	
		145 ⇄ 149	On	
		150 ⇄ 164	Strobe 6 (Random slow on, fast off), fast to slow	
		165 ⇄ 169	On	
		170 ⇄ 184	Strobe 7 (Pulse), fast to slow	
		185 ⇄ 189	On	
		190 ⇄ 204	Strobe 8 (Random pulse), fast to slow	
		205 ⇄ 209	On	
		210 ⇄ 224	Strobe 9 (Fade in, fade out), fast to slow	
		225 ⇄ 229	On	
230 ⇄ 244	Strobe 10 (Random pulse), fast to slow			
245 ⇄ 255	On			
10	Control	000 ⇄ 009	No function	
		010 ⇄ 014	Manual tilt blackout	
		015 ⇄ 019	Cancel manual tilt blackout	
		020 ⇄ 024	1 fixture macro	
		025 ⇄ 029	2 fixture macro 1	
		030 ⇄ 034	2 fixture macro 2	
		035 ⇄ 039	4 fixture macro 1	
		040 ⇄ 044	4 fixture macro 2	
		045 ⇄ 049	4 fixture macro 3	
		050 ⇄ 054	4 fixture macro 4	
		055 ⇄ 059	Pan reset	
		060 ⇄ 064	Tilt reset	
		065 ⇄ 069	No function (reserved for future use)	
		070 ⇄ 074	Reset all	
		075 ⇄ 079	No function (reserved for future use)	
		080 ⇄ 084	Pan/Tilt reverse	
		085 ⇄ 089	Pan reverse	
		090 ⇄ 094	Tilt reverse	
		095 ⇄ 099	Cancel pan reverse	
		100 ⇄ 104	Cancel tilt reverse	
		105 ⇄ 109	Cancel pan/tilt reverse	
		110 ⇄ 114	No function (reserved for future use)	
		115 ⇄ 119	Link all heads to head 1	
		120 ⇄ 124	Unlink all heads from head 1	
		125 ⇄ 134	No function (reserved for future use)	
		135 ⇄ 139	Dimmer speed mode fast	
140 ⇄ 144	Dimmer speed mode smooth			
145 ⇄ 255	No function			



### Dual Control Pixel Values

<b>RGBW Mode</b> (20-channel)	<b>Channel</b>	<b>Function</b>	<b>Value</b>	<b>Percent/Settings</b>
	1	Red 1	000 ⇄ 255	RGBW mode: 0–100% / CMY mode: 100%–0
	2	Green 1	000 ⇄ 255	RGBW mode: 0–100% / CMY mode: 100%–0
	3	Blue 1	000 ⇄ 255	RGBW mode: 0–100% / CMY mode: 100%–0
	4	White 1	000 ⇄ 255	RGBW mode: 0–100% / CMY mode: 100%–0
	5	Red 2	000 ⇄ 255	RGBW mode: 0–100% / CMY mode: 100%–0
	6	Green 2	000 ⇄ 255	RGBW mode: 0–100% / CMY mode: 100%–0
	7	Blue 2	000 ⇄ 255	RGBW mode: 0–100% / CMY mode: 100%–0
	8	White 2	000 ⇄ 255	RGBW mode: 0–100% / CMY mode: 100%–0
	9	Red 3	000 ⇄ 255	RGBW mode: 0–100% / CMY mode: 100%–0
	10	Green 3	000 ⇄ 255	RGBW mode: 0–100% / CMY mode: 100%–0
	11	Blue 3	000 ⇄ 255	RGBW mode: 0–100% / CMY mode: 100%–0
	12	White 3	000 ⇄ 255	RGBW mode: 0–100% / CMY mode: 100%–0
	13	Red 4	000 ⇄ 255	RGBW mode: 0–100% / CMY mode: 100%–0
	14	Green 4	000 ⇄ 255	RGBW mode: 0–100% / CMY mode: 100%–0
	15	Blue 4	000 ⇄ 255	RGBW mode: 0–100% / CMY mode: 100%–0
	16	White 4	000 ⇄ 255	RGBW mode: 0–100% / CMY mode: 100%–0
	17	Red 5	000 ⇄ 255	RGBW mode: 0–100% / CMY mode: 100%–0
	18	Green 5	000 ⇄ 255	RGBW mode: 0–100% / CMY mode: 100%–0
	19	Blue 5	000 ⇄ 255	RGBW mode: 0–100% / CMY mode: 100%–0
	20	White 5	000 ⇄ 255	RGBW mode: 0–100% / CMY mode: 100%–0

<b>RGB Mode</b> (15-channel)	<b>Channel</b>	<b>Function</b>	<b>Value</b>	<b>Percent/Settings</b>
	1	Red 1	000 ⇄ 255	RGBW mode: 0–100% / CMY mode: 100%–0
	2	Green 1	000 ⇄ 255	RGBW mode: 0–100% / CMY mode: 100%–0
	3	Blue 1	000 ⇄ 255	RGBW mode: 0–100% / CMY mode: 100%–0
	4	Red 2	000 ⇄ 255	RGBW mode: 0–100% / CMY mode: 100%–0
	5	Green 2	000 ⇄ 255	RGBW mode: 0–100% / CMY mode: 100%–0
	6	Blue 2	000 ⇄ 255	RGBW mode: 0–100% / CMY mode: 100%–0
	7	Red 3	000 ⇄ 255	RGBW mode: 0–100% / CMY mode: 100%–0
	8	Green 3	000 ⇄ 255	RGBW mode: 0–100% / CMY mode: 100%–0
	9	Blue 3	000 ⇄ 255	RGBW mode: 0–100% / CMY mode: 100%–0
	10	Red 4	000 ⇄ 255	RGBW mode: 0–100% / CMY mode: 100%–0
	11	Green 4	000 ⇄ 255	RGBW mode: 0–100% / CMY mode: 100%–0
	12	Blue 4	000 ⇄ 255	RGBW mode: 0–100% / CMY mode: 100%–0
	13	Red 5	000 ⇄ 255	RGBW mode: 0–100% / CMY mode: 100%–0
	14	Green 5	000 ⇄ 255	RGBW mode: 0–100% / CMY mode: 100%–0
	15	Blue 5	000 ⇄ 255	RGBW mode: 0–100% / CMY mode: 100%–0

## Operating Settings Configuration

### Home Screen

The Rogue R1 FX-B has a home screen that shows the current control protocols, personalities, starting addresses, IP addresses, and universes. To see the home screen, press **<MENU>** repeatedly until it shows on the display. From the home screen, touch any of the displayed control settings to immediately jump to that part of the menu, such as the personality, starting address, or universe, or press **<ENTER>** to reach the main menu.

### Test Mode

**Auto Test** To perform an auto test of the Rogue R1 FX-B functions, follow the instructions below:

1. Press **<MENU>** repeatedly until the [Home Screen](#) shows on the display. Press **<ENTER>**.
2. Use **<UP>**, **<DOWN>**, **<LEFT>**, or **<RIGHT>** to select **Test Mode**, or touch the display where it says **Test Mode**.
3. If using the buttons instead of the touchscreen, press **<ENTER>**.
4. Use **<UP>** or **<DOWN>** to select **Auto test**, or touch the display where it says **Auto test**.
5. Press **<ENTER>**.

**Manual Test** To test the functions of the product manually, do the following:

1. Press **<MENU>** repeatedly until the [Home Screen](#) shows on the display. Press **<ENTER>**.
2. Use **<UP>**, **<DOWN>**, **<LEFT>**, or **<RIGHT>** to select **Test Mode**, or touch the display where it says **Test Mode**.
3. If using the buttons instead of the touchscreen, press **<ENTER>**.
4. Use **<UP>** or **<DOWN>** to select **Manual test**, or touch the display where it says **Manual test**.
5. If using the buttons instead of the touchscreen, press **<ENTER>**.
6. Use **<UP>** or **<DOWN>** to select the function to test, from **Pan, Pan Speed, Pan 360, Tilt 1, Tilt 2, Tilt 3, Tilt 4, Tilt 5, Tilt Speed, Tilt 1 360, Tilt 2 360, Tilt 3 360, Tilt 4 360, Tilt 5 360, Dimmer, Shutter, Red, Green, Blue, White, Color, LED Macro, or LED Macro Speed**, or touch the display where it says the desired function.
7. If using the buttons instead of the touchscreen, press **<ENTER>**.
8. Change the value of the tested function with one of the following methods:
  - Type the desired value using the number pad that shows on the touchscreen display.
  - or
  - Use **<UP>**, **<RIGHT>**, **<DOWN>**, or **<LEFT>** to increase or decrease the value.
9. Press **<ENTER>**.

### Setup

To reach the **Setup** menu, follow the instructions below:

1. Press **<MENU>** repeatedly until the [Home Screen](#) shows on the display. Press **<ENTER>**.
2. Use **<UP>**, **<DOWN>**, **<LEFT>**, or **<RIGHT>** to select **Setup**, or touch the display where it says **Setup**.
3. If using the buttons instead of the touchscreen, press **<ENTER>**.

## Network Settings

**IP Mode** The IP address of the Rogue R1 FX-B can be set manually, by the network, or to a pre-set static address specific to each product. To set the IP Mode, follow the instructions below:

1. Navigate to the [Setup](#) menu.
2. Use **<UP>** or **<DOWN>** to select **Network Settings**, or touch the display where it says **Network Settings**.
3. If using the buttons instead of the touchscreen, press **<ENTER>**.
4. Use **<UP>** or **<DOWN>** to select **IP Mode**, or touch the display where it says **IP Mode**.
5. If using the buttons instead of the touchscreen, press **<ENTER>**.
6. Use **<UP>**, **<DOWN>**, **<LEFT>**, or **<RIGHT>** to select from:
  - **Manual** (set the IP address with the control panel),
  - **DHCP** (the network sets the IP address),
  - or
  - **Static** (a pre-set address specific to each product),
 or touch the display where it says the desired mode.
7. Press **<ENTER>**.

**IP Address** In **Manual IP Mode**, the IP address must be assigned through the product menu. To set the IP address in **Manual IP Mode**, do the following:

1. Navigate to the [Setup](#) menu.
2. Use **<UP>** or **<DOWN>** to select **Network Settings**, or touch the display where it says **Network Settings**.
3. If using the buttons instead of the touchscreen, press **<ENTER>**.
4. Use **<UP>** or **<DOWN>** to select **IP**, or touch the display where it says **IP**.
5. If using the buttons instead of the touchscreen, press **<ENTER>**.
6. Set the IP address (from **000.000.000.000** to **255.255.255.255**) with one of the following methods:
  - Through the touchscreen:
    - a. Touch the display where it shows the byte (set of three numbers) to be changed.
    - b. Use the number pad on the display to enter the desired number.
    - c. Repeat until the IP address is set as desired.
  - With the buttons:
    - a. Use **<LEFT>** or **<RIGHT>** to select the byte (set of three numbers) to be changed).
    - b. Use **<UP>** or **<DOWN>** to increase or decrease the value.
    - c. Repeat until the IP address is set as desired.
7. Press **<ENTER>**.

**Subnet Mask** In **Manual IP Mode**, the Subnet Mask must be assigned through the product menu. To set the Subnet Mask in **Manual IP Mode**, do the following:

1. Navigate to the [Setup](#) menu.
2. Use **<UP>** or **<DOWN>** to select **Network Settings**, or touch the display where it says **Network Settings**.
3. If using the buttons instead of the touchscreen, press **<ENTER>**.
4. Use **<UP>** or **<DOWN>** to select **SubMask**, or touch the display where it says **SubMask**.
5. If using the buttons instead of the touchscreen, press **<ENTER>**.
6. Set the Subnet Mask (from **000.000.000.000** to **255.255.255.255**) with one of the following methods.
  - Through the touchscreen:
    - a. Touch the display where it shows the byte (set of three numbers) to be changed.
    - b. Use the number pad on the display to enter the desired number.
    - c. Repeat until the Subnet Mask is set as desired.
  - With the buttons:
    - a. Use **<LEFT>** or **<RIGHT>** to select the byte (set of three numbers) to be changed).
    - b. Use **<UP>** or **<DOWN>** to increase or decrease the value.
    - c. Repeat until the Subnet Mask is set as desired.
7. Press **<ENTER>**.



**In DHCP or Static IP Mode, the IP and SubMask menu settings have no effect on the product.**

- Pan/Tilt Orientation** To set whether the pan or tilt orientation is normal or inverted:"
1. Navigate to the [Setup](#) menu.
  2. Use **<UP>** or **<DOWN>** to select **Pan Reverse** or **Tilt Reverse**, or touch the display where it says the desired setting.
  3. If using the buttons instead of the touchscreen, press **<ENTER>**.
  4. Use **<UP>**, **<DOWN>**, **<LEFT>**, or **<RIGHT>** to select **NO** (normal orientation) or **YES** (inverted orientation), or touch the display where it says the desired option.
  5. Press **<ENTER>**.
- Display Orientation** To set which way the display faces, do the following:
1. Navigate to the [Setup](#) menu.
  2. Use **<UP>** or **<DOWN>** to select **Screen Reverse**, or touch the display where it says **Screen Reverse**.
  3. If using the buttons instead of the touchscreen, press **<ENTER>**.
  4. Use **<UP>**, **<DOWN>**, **<LEFT>**, or **<RIGHT>** to select **NO** (display is normal), **YES** (display is inverted), or **AUTO** (the display automatically detects which way the product is facing and orients itself accordingly), or touch the display where it says the desired option.
  5. Press **<ENTER>**.
- Pan/Tilt Angle Range** To set the range of motion the pan or tilt is permitted:
1. Navigate to the [Setup](#) menu.
  2. Use **<UP>** or **<DOWN>** to select **Pan Angle** or **Tilt Angle**, or touch the display where it says the desired setting.
  3. If using the buttons instead of the touchscreen, press **<ENTER>**.
  4. Use **<UP>**, **<DOWN>**, **<LEFT>**, or **<RIGHT>** to select **540** (540°), **360** or **270** (360° or 270° for pan or tilt respectively) or **180** (180°), or touch the display where it says the desired option.
  5. Press **<ENTER>**.
- Blackout on Pan/Tilt Movement** To set whether the product will black out during pan or tilt movement, follow the instructions below:
1. Navigate to the [Setup](#) menu.
  2. Use **<UP>** or **<DOWN>** to select **BL. O. P/T Move**, or touch the display where it says **BL. O. P/T Move**.
  3. If using the buttons instead of the touchscreen, press **<ENTER>**.
  4. Use **<UP>**, **<DOWN>**, **<LEFT>**, or **<RIGHT>** to select **NO** (do not black out) or **YES** (black out during movement), or touch the display where it says the desired option.
  5. Press **<ENTER>**.
- Touchscreen Calibration** If the touchscreen is not responding correctly, it may need to be calibrated. To do so:
1. Navigate to the [Setup](#) menu.
  2. Use **<UP>** or **<DOWN>** to select **Calibration**, or touch the display where it says **Calibration**.
  3. If using the buttons instead of the touchscreen, press **<ENTER>**.
  4. Use **<UP>**, **<DOWN>**, **<LEFT>**, or **<RIGHT>** to select **NO** (do not calibrate) or **YES** (calibrate), or touch the display where it says the desired option.
  5. Press **<ENTER>**.
  6. Follow the instructions, touching the points as they appear on the display.
- Touchscreen Lock** To lock or unlock the touchscreen control panel, do the following:
1. Navigate to the [Setup](#) menu.
  2. Use **<UP>** or **<DOWN>** to select **Touchscreen Lock**, or touch the display where it says **Touchscreen Lock**.
  3. If using the buttons instead of the touchscreen, press **<ENTER>**.
  4. Use **<UP>**, **<DOWN>**, **<LEFT>**, or **<RIGHT>** to select **NO** (display will respond to touch) or **YES** (display will not respond to touch), or touch the display where it says the desired option.
  5. Press **<ENTER>**.

**Lock Screen** To completely lock or unlock the control panel, follow the instructions below:

1. Navigate to the [Setup](#) menu.
2. Use **<UP>** or **<DOWN>** to select **Lock Screen**, or touch the display where it says **Lock Screen**.
3. If using the buttons instead of the touchscreen, press **<ENTER>**.
4. Use **<UP>**, **<DOWN>**, **<LEFT>**, or **<RIGHT>** to select **NO** (control panel will not lock) or **YES** (control panel will require a passcode to access), or touch the display where it says the desired option.
5. Press **<ENTER>**.

To access the control panel when it has been locked:

1. Press **<MENU>**.
2. Enter the passcode **0920** using one of the following methods:
  - Through the touchscreen: use the number pad on the screen to enter **0920**.
  - With the buttons:
    - a. Use **<DOWN>** to select the number to be changed.
    - b. Use **<UP>** to increase the value.
    - c. Repeat until **0920** has been entered.
3. Press **<ENTER>**.

**Backlight Timer** To set the amount of time after inactivity before the display backlight turns off:

1. Navigate to the [Setup](#) menu.
2. Use **<UP>** or **<DOWN>** to select **Backlight Timer**, or touch the display where it says **Backlight Timer**.
3. If using the buttons instead of the touchscreen, press **<ENTER>**.
4. Use **<UP>**, **<DOWN>**, **<LEFT>**, or **<RIGHT>** to select **30S** (after 30 seconds of inactivity), **1M** (after 1 minute of inactivity), **5M** (after 5 minutes of inactivity), or **ON** (does not turn off), or touch the display where it says the desired option.
5. Press **<ENTER>**.

**Loss of Data** In case of an input signal being lost in any way, the Rogue R1 FX-B will respond in one of two ways. The product will either hold the last signal received, or black out all LED output.

To set which way the product responds, follow the instructions below:

1. Navigate to the [Setup](#) menu.
2. Use **<UP>** or **<DOWN>** to select **Loss of Data**, or touch the display where it says **Loss of Data**.
3. If using the buttons instead of the touchscreen, press **<ENTER>**.
4. Use **<UP>**, **<DOWN>**, **<LEFT>**, or **<RIGHT>** to select **Hold** (hold last signal received) or **Close** (black out all LED output), or touch the display where it says the desired option.
5. Press **<ENTER>**.

**Color Mixing Mode** The Rogue R1 FX-B has an additive color mixing mode, and a subtractive color mixing mode. In the additive color mixing mode, a value of 000 on a color LED channel gives zero output, and a value of 255 on that channel gives full output. In the subtractive color mixing mode, a value of 000 on a color LED channel gives full output, and a value of 255 on that channel gives zero output.

To set the color mixing mode:

1. Navigate to the [Setup](#) menu.
2. Use **<UP>** or **<DOWN>** to select **C Mixing Mode**, or touch the display where it says **C Mixing Mode**.
3. If using the buttons instead of the touchscreen, press **<ENTER>**.
4. Use **<UP>**, **<DOWN>**, **<LEFT>**, or **<RIGHT>** to select **RGBW** (additive color mixing), or **CMY** (subtractive color mixing), or touch the display where it says the desired option.
5. Press **<ENTER>**.

**Dimmer Curve** To set the dimmer curve, follow the instructions below:

1. Navigate to the [Setup](#) menu.
2. Use **<UP>** or **<DOWN>** to select **Dimmer Curve**, or touch the display where it says **Dimmer Curve**.
3. If using the buttons instead of the touchscreen, press **<ENTER>**.
4. Use **<UP>**, **<DOWN>**, **<LEFT>**, or **<RIGHT>** to select **Linear**, **Square**, **I Squa**, or **SCurve**, or touch the display where it says the desired option.
5. Press **<ENTER>**.

- Dimmer Speed** To set the dimmer speed, do the following:
1. Navigate to the [Setup](#) menu.
  2. Use **<UP>** or **<DOWN>** to select **Dimmer Speed**, or touch the display where it says **Dimmer Speed**.
  3. If using the buttons instead of the touchscreen, press **<ENTER>**.
  4. Use **<UP>**, **<DOWN>**, **<LEFT>**, or **<RIGHT>** to select **Smooth** or **Fast**, or touch the display where it says the desired option.
  5. Press **<ENTER>**.
- PWM Option** To set the PWM frequency, do the following:
1. Navigate to the [Setup](#) menu.
  2. Use **<UP>** or **<DOWN>** to select **PWM Option**, or touch the display where it says **PWM Option**.
  3. If using the buttons instead of the touchscreen, press **<ENTER>**.
  4. Use **<UP>**, **<DOWN>**, **<LEFT>**, or **<RIGHT>** to select **600Hz**, **1200Hz**, **2000Hz**, **4000Hz**, **6000Hz**, or **25000Hz**, or touch the display where it says the desired option.
  5. Press **<ENTER>**.
- Color Balance** To set the maximum values of a given color in the mix, follow the instructions below:
1. Navigate to the [Setup](#) menu.
  2. Use **<UP>** or **<DOWN>** to select **Color Balance**, or touch the display where it says **Color Balance**.
  3. If using the buttons instead of the touchscreen, press **<ENTER>**.
  4. Use **<UP>** or **<DOWN>**, to select the color value to be changed, from **Red**, **Green**, **Blue**, or **White**, or touch the display where it says the desired option.
  5. If using the buttons instead of the touchscreen, press **<ENTER>**.
  6. Set the color value with one of the following methods:
    - Type the desired value using the number pad that shows on the touchscreen display.
    - or
    - Use **<UP>**, **<RIGHT>**, **<DOWN>**, or **<LEFT>** to increase or decrease the value.
  7. Press **<ENTER>**.
  8. Repeat steps 4–7 until color balance is set as desired.
- Preset Select** This option saves 3 different preset menu option configurations. To record and set these presets follow the instructions below:
1. Navigate to the [Setup](#) menu.
  2. Use **<UP>** or **<DOWN>** to select **Preset Select**, or touch the display where it says **Preset Select**.
  3. If using the buttons instead of the touchscreen, press **<ENTER>**.
  4. Use **<UP>**, **<DOWN>**, **<LEFT>**, or **<RIGHT>** to select **PRESET A**, **PRESET B** or **PRESET C**, or touch the display where it says the desired option.
  5. Press **<ENTER>**.
  6. The product will reset. Any changes made to the menu options will be saved to this preset.
    - **Default is PRESET A. If you make changes inside PRESET A, those changes are saved to PRESET A without having to do anything.**
    - **To create a new preset, highlight and select PRESET SELECT. Highlight PRESET B or PRESET C and press <ENTER>. When you make that selection, the product will reset automatically. Go back and make the changes you need to make in the menu. This will automatically save to the preset you are in.**



**Preset Sync** To sync all menu presets to other Rogue R1 FX-Bs, follow the instructions below:

1. Connect all Rogue R1 FX-B via DMX cable.
  2. Navigate to the [Setup](#) menu.
  3. Use **<UP>** or **<DOWN>** to select **Preset Sync**, or touch the display where it says **Preset Sync**
  4. If using the buttons instead of the touchscreen, press **<ENTER>**.
  5. Select **YES** or touch the display where it says the desired option.
  6. Press **<ENTER>**.
- **To sync other Rogue R1 FX-Bs, you connect those products by a DMX cable.**
  - **The product can be in any control mode except WDMX. ArtNet, DMX, sACN are all acceptable.**
  - **All menu options are transferred, including the DMX address. Only the IP address is not affected in the other products.**



**Reset Functions** To reset the pan, tilt, or all functions as if from startup:

1. Navigate to the [Setup](#) menu.
2. Use **<UP>** or **<DOWN>** to select **Reset Function**, or touch the display where it says **Reset Function**.
3. If using the buttons instead of the touchscreen, press **<ENTER>**.
4. Use **<UP>** or **<DOWN>** to select the function to reset, from **Pan**, **Tilt**, or **All**, or touch the display where it says the desired option.
5. If using the buttons instead of the touchscreen, press **<ENTER>**.
6. Use **<UP>**, **<DOWN>**, **<LEFT>**, or **<RIGHT>** to select from **NO** (do not reset) or **YES** (reset), or touch the display where it says the desired option.
7. Press **<ENTER>**.

**Factory Reset** To restore the Rogue R1 FX-B to factory default settings, do the following:

1. Navigate to the [Setup](#) menu.
2. Use **<UP>** or **<DOWN>** to select **Factory Settings**, or touch the display where it says **Factory Settings**.
3. If using the buttons instead of the touchscreen, press **<ENTER>**.
4. Use **<UP>**, **<DOWN>**, **<LEFT>**, or **<RIGHT>** to select **NO** (do not reset) or **YES** (reset to factory settings), or touch the display where it says the desired option.
5. Press **<ENTER>**.

## System Information

All information about the current status of the Rogue R1 FX-B is available through the product's **Sys Info** menu. To view this information, follow the instructions below:

1. Press **<MENU>** repeatedly until the [Home Screen](#) shows on the display. Press **<ENTER>**.
2. Use **<UP>**, **<DOWN>**, **<LEFT>**, or **<RIGHT>** to select **Sys Info**, or touch the display where it says **Sys Info**.
3. If using the buttons instead of the touchscreen, press **<ENTER>**.
4. Use **<UP>** or **<DOWN>** to select from **Fixture Information** (shows firmware version, running mode, starting address, etc.), **Error Information** (shows any errors or No Error!), or **Channel Information** (shows the current value of all signal input channels) or touch the display where it says the desired option.
5. Press **<ENTER>**.
6. Use **<UP>** or **<DOWN>** to scroll through the information.

**Offset Mode** The Offset mode provides fine adjustments for the home position of all the moving parts in the optical path as well as the pan and tilt movements. This way, when in their home position, the moving parts do not show any border or reduce the light output.

1. Starting from the Main Level screen, press and hold **<MENU>** until the passcode screen appears.
2. Enter the passcode **2323** using one of the following methods:
  - Through the touchscreen: use the number pad on the screen to enter **2323**.
  - With the buttons:
    - a. Use **<DOWN>** to select the number to be changed.
    - b. Use **<UP>** to increase the value.
    - c. Repeat until **2323** has been entered.
3. Press **<ENTER>**.

This brings you into the Zero Adjust menu screen.

**PAN** To adjust the starting point of the pan motor, follow the instructions below:

1. Use **<UP>** or **<DOWN>** to select **PAN**.
2. Press **<ENTER>**.
3. Use **<UP>** or **<DOWN>** to increase or decrease the starting value, from **000–255**.
4. Press **<ENTER>**.

**TILT** To adjust the starting point of any of the tilt motors, do the following:

1. Use **<UP>** or **<DOWN>** to select **TILT1**, **TILT2**, **TILT3**, **TILT4**, or **TILT5**.
2. Press **<ENTER>**.
3. Use **<UP>** or **<DOWN>** to increase or decrease the starting value, from **000–255**.
4. Press **<ENTER>**.

**MAC Address** To assign the fourth, fifth, or sixth digit of the MAC address, follow the instructions below:

1. Use **<UP>** or **<DOWN>** to select **MAC4**, **MAC5**, or **MAC6**.
2. Press **<ENTER>**.
3. Use **<UP>** or **<DOWN>** to increase or decrease the value, from **000–255**.
4. Press **<ENTER>**.



## 5. FIRMWARE UPDATE

The following steps apply to the Windows® 7 operating system:

- Step 1**
1. Connect the Rogue R1 FX-B to a computer with an ethernet cable.
  2. Verify the network with the Rogue R1 FX-B is connected to the computer.

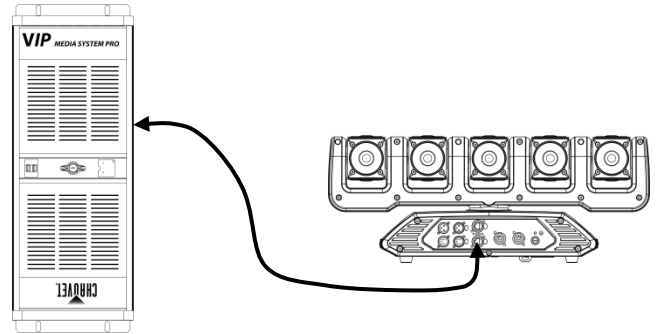

- Step 2**
1. Set the control protocol on the Rogue R1 FX-B to **ArtNet** in **Single Control** mode. (See [Single Control Protocol](#))
  2. Set the **IP Mode** to **Static**. (See [IP Mode](#))

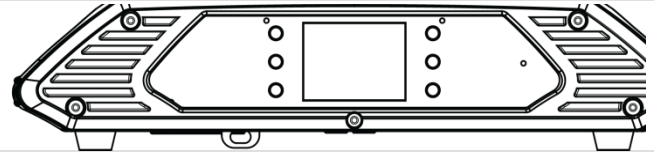

- Step 3**
- On the computer, open the Network and Sharing Center (through the Start Menu, the Control Panel, or the Network icon on the right side of the Taskbar).

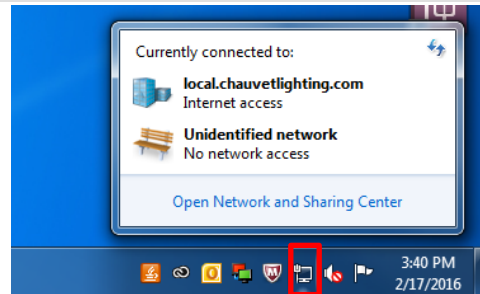

- Step 4**
- Select the network which the product is connected to by clicking the blue text that corresponds to that network on the right side of the window.

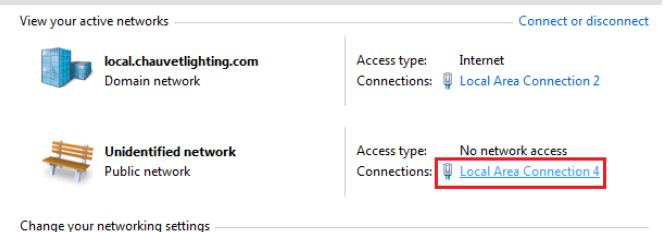

**Step 5** Click **Properties** on the **Status** window that pops up.

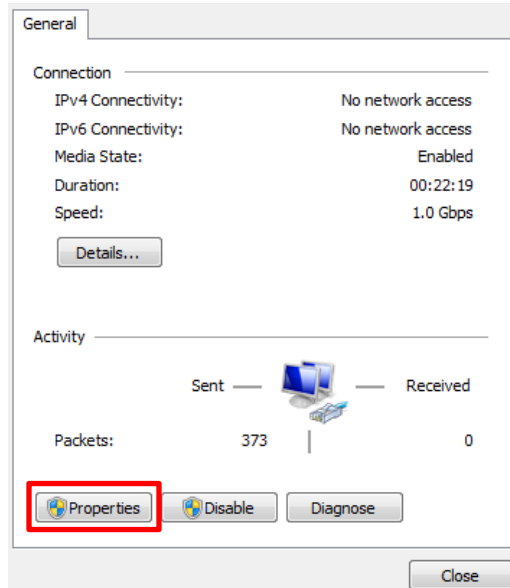

**Step 6** On the **Properties** window:

1. Click on **Internet Protocol Version 4 (TCP/IPv4)** to select it.
2. Click **Properties**.

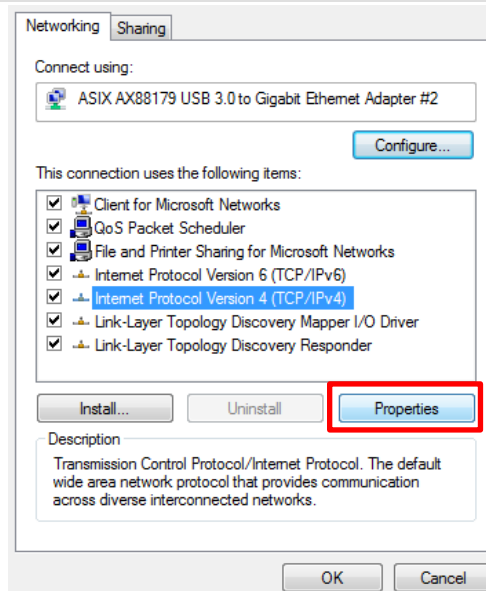

**Step 7** On the **TCP/IPv4 Properties** window:

1. Select **Use the following IP address**:
2. Type **2.255.0.0** into the **IP address** bar.
3. Press **<Tab>** on your keyboard. The **Subnet mask** bar should automatically populate as **255.0.0.0**. If not, then enter it manually.
4. Ignore the **Default gateway** bar.

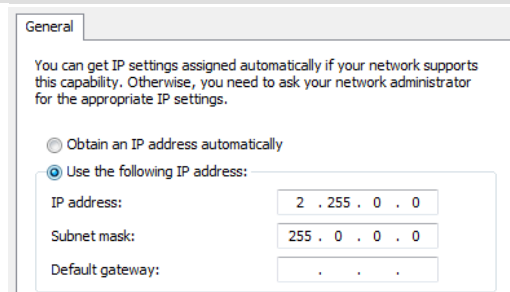

- Step 8**
1. View the Home Screen on the Rogue R1 FX-B. (see [Home Screen](#))
  2. Open the internet browser on the computer.
  3. Enter the IP address from the Rogue R1 FX-B display into the URL bar of the internet browser. (For example, if the display of the product reads **2.8.0.0**, enter **2.8.0.0** into the URL bar of the internet browser.)

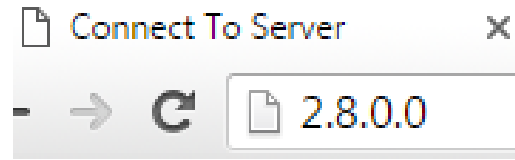

- Step 9** On the **Welcome** screen:
1. Enter **admin** as both the **User Name** and **Password**. No capital letters.
  2. Press **Log In** on the screen, or **<Enter>** on the keyboard.
- If the user name and password do not work, reset the product to factory defaults. (see [Factory Reset](#))

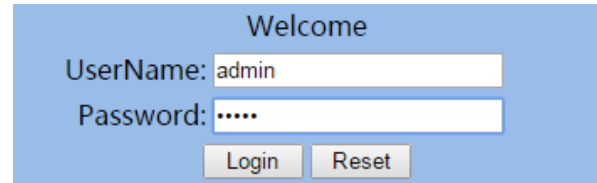

- Step 10** On the page that appears, click **Upgrade**.

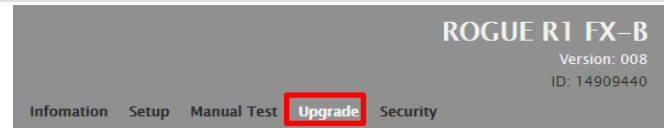

- Step 11**
1. Click **Choose File** on the Rogue R1 FX-B Upgrade page.
  2. In the File Explorer window that pops up, select the Firmware Upgrade file from the website and click **Open**.
  3. Click **Upload File**.
- A **Downloading** message will appear on the product's display. Once the product finishes installing the firmware, it will reset.  
Do NOT turn the product off during this process.

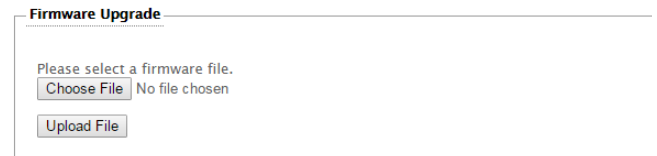

- Step 12** On the Rogue R1 FX-B:
1. Verify the firmware has been updated by navigating to **Sys Info** ([System Information](#)) and checking that the version number matches the name of the file on the computer.

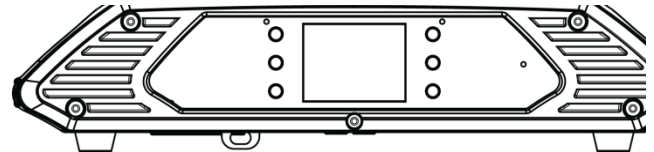

- Step 13** Disconnect the Rogue R1 FX-B from the computer. The firmware update is complete.



**The examples shown are for illustrative purposes.**

## 6. TECHNICAL INFORMATION

### Product Maintenance

To maintain optimum performance and minimize wear, you should clean this product frequently. Usage and environment are contributing factors in determining the cleaning frequency.

As a rule, clean this product at least twice a month. Dust build-up reduces light output performance and can cause overheating. This can lead to reduced light source life and increased mechanical wear.

To clean your product:

1. Unplug the product from power.
2. Wait until the product is at room temperature.
3. Use a vacuum (or dry compressed air) and a soft brush to remove dust collected on the external vents.
4. Clean all external surfaces with a mild solution of non-ammonia glass cleaner or isopropyl alcohol.
5. Apply the solution directly to a soft, lint-free cotton cloth or a lens cleaning tissue.
6. Wipe any dirt or grime to the outside edges of the lens surface.
7. Gently polish the lens surfaces until they are free of haze and lint.



**Always dry the external surfaces thoroughly and carefully after cleaning them.**



**Do not spin the cooling fans by blowing compressed air into them.**

## 7. TECHNICAL SPECIFICATIONS

<b>Dimensions and Weight</b>	<b>Length</b>	<b>Width</b>	<b>Height</b>	<b>Weight</b>		
	25.19 in (640 mm)	7.05 in (179 mm)	9.72 in (247 mm)	24.2 lb (11 kg)		
<b>Note:</b> Dimensions in inches rounded to the nearest decimal digit.						
<b>Electrical</b>	<b>Power Supply Type</b>	<b>Range</b>	<b>Voltage Selection</b>			
	Switching (internal)	100–240 VAC, 50/60 Hz	Auto-ranging			
	<b>Parameter</b>	<b>100 VAC, 60 Hz</b>	<b>120 VAC, 60 Hz</b>	<b>208 VAC, 60 Hz</b>	<b>230 VAC, 50 Hz</b>	<b>240 VAC, 60 Hz</b>
	Consumption	179 W	176 W	171 W	167 W	162 W
	Current	1.83 A	1.48 A	0.796 A	0.757 A	0.713 A
	Power linking current (products)	12 A (6 products)	12 A (8 products)	12 A (15 products)	12 A (16 products)	12 A (16 products)
	Fuse/Breaker	F 3 A, 250 V	F 3 A, 250 V	F 3 A, 250 V	F 3 A, 250 V	F 3 A, 250 V
		<b>Power I/O</b>	<b>U.S./Canada</b>		<b>Worldwide</b>	
	Power input connector	Neutrik® powerCON® A		Neutrik® powerCON® A		
	Power output connector	Neutrik® powerCON® B		Neutrik® powerCON® B		
	Power cord plug	Edison (U.S.)		Local plug		
<b>Light Source</b>	<b>Type</b>	<b>Power</b>		<b>Lifespan</b>		
	LED	15 W		50,000 hours		
	<b>Color</b>	<b>Quantity</b>		<b>Current</b>		
	Quad-color RGBW	5		4 A		
<b>Photo Optic</b>	<b>Installed Optics</b>	<b>Beam Angle</b>		<b>Field Angle</b>		
	5°	6.2°		10.1°		
	<b>Cutoff Angle</b>	<b>Illuminance @ 5 m</b>				
	12.7°	6,008 lux				
<b>DMX</b>	<b>I/O Connector</b>	<b>Channel Range</b>				
	3- and 5-pin XLR	9, 15, 17, 18, 20, 23, 25, or 47				
<b>Art-Net™</b>	<b>I/O Connector</b>	<b>Channel Range</b>				
	Neutrik® etherCON®	9, 15, 17, 18, 20, 23, 25, or 47				
<b>ArKaos Kling-Net</b>	<b>I/O Connector</b>	<b>Channel Range</b>				
	Neutrik® etherCON®	Determined per ArKaos MediaMaster software				
<b>Thermal</b>	<b>Max. External Temperature</b>	<b>Cooling System</b>				
	113 °F (45 °C)	Fan-Assisted Convection				
<b>Ordering</b>	<b>Product Name</b>	<b>Item Name</b>	<b>Item Code</b>	<b>UPC Number</b>		
	Rogue R1 FX-B	ROGUER1FXB	08011203	781462215514		



UL 1573  
CSA C22.2 No. 166  
E113093



## RETURNS

Send the product prepaid, in the original box, and with the original packing and accessories. Chauvet will not issue call tags.

Call Chauvet and request a Return Merchandise Authorization (RMA) number before shipping the product. Be prepared to provide the model number, serial number, and a brief description of the cause(s) for the return.

To submit a service request online, go to [www.chauvetprofessional.com/service-request](http://www.chauvetprofessional.com/service-request).

Clearly label the package with an RMA number. Chauvet will refuse any product returned without an RMA number.



**Write the RMA number on a properly affixed label. DO NOT write the RMA number directly on the box.**

Once you have the RMA number, provide the following information on a piece of paper and place it inside the box:

- Your name
- Your address
- Your phone number
- RMA number
- A brief description of the problem

Be sure to pack the product properly. Any shipping damage resulting from inadequate packaging will be your responsibility. FedEx packing or double-boxing are recommended.



**Chauvet reserves the right to use its own discretion to repair or replace returned product(s).**

# CONTACT Us

General Information	Technical Support
<b>Chauvet World Headquarters</b>	
Address: 5200 NW 108th Avenue Sunrise, FL 33351 Voice: (954) 577-4455 Toll free: (800) 762-1084	Voice: (844) 393-7575 Email: <a href="mailto:chauvetcs@chauvetlighting.com">chauvetcs@chauvetlighting.com</a>  Website: <a href="http://www.chauvetprofessional.com/">http://www.chauvetprofessional.com/</a>
<b>Chauvet U.K.</b>	
Address: Unit 1C Brookhill Road Industrial Estate Pinxton, Nottingham, UK NG16 6NT Voice: +44 (0)1773 511115	Email: <a href="mailto:uktech@chauvetlighting.com">uktech@chauvetlighting.com</a>  Website: <a href="http://www.chauvetlighting.co.uk">www.chauvetlighting.co.uk</a>
<b>Chauvet Benelux</b>	
Address: Stokstraat 18 9770 Kruishoutem Belgium Voice: +32 9 388 93 97	Email: <a href="mailto:Eutech@chauvetlighting.com">Eutech@chauvetlighting.com</a>  Website: <a href="http://www.chauvetlighting.eu">www.chauvetlighting.eu</a>
<b>Chauvet France</b>	
Address: 3, Rue Ampère 91380 Chilly-Mazarin France Voice: +33 1 78 85 33 59	Email: <a href="mailto:Eutech@chauvetlighting.com">Eutech@chauvetlighting.com</a>  Website: <a href="http://www.chauvetlighting.eu">www.chauvetlighting.eu</a>
<b>Chauvet Germany</b>	
Address: Bruno-Bürgel-Str. 11 28759 Bremen Germany Voice: +49 421 62 60 20	Email: <a href="mailto:Eutech@chauvetlighting.com">Eutech@chauvetlighting.com</a>  Website: <a href="http://www.chauvetlighting.eu">www.chauvetlighting.eu</a>
<b>Chauvet Mexico</b>	
Address: Av. de las Partidas 34-3B (Entrance by Calle 2) Zona Industrial Lerma Lerma, Mexico C.P. 52000 Voice: +52 (728) 690-2010	Email: <a href="mailto:servicio@chauvet.com.mx">servicio@chauvet.com.mx</a>  Website: <a href="http://www.chauvet.com.mx">www.chauvet.com.mx</a>

Visit the applicable website above to verify our contact information and instructions to request support. Outside the U.S., U.K., Ireland, Benelux, France, Germany, or Mexico, contact the dealer of record.