

MAVERICK STORM

3 BEAMWASH

User Manual



Model ID: MAVERICKSTORM3BEAMWASH-2

CHAUVET
PROFESSIONAL

Edition Notes

The Maverick Storm 3 BeamWash User Manual includes a description, safety precautions, installation, programming, operation, and maintenance instructions for the Maverick Storm 3 BeamWash as of the release date of this edition.

Trademarks

Chauvet, Chauvet Professional, the Chauvet logo, Maverick, and Maverick Storm 3 BeamWash are registered trademarks or trademarks of Chauvet & Sons, LLC (d/b/a Chauvet and Chauvet Lighting) in the United States and other countries. Other company and product names and logos referred to herein may be trademarks of their respective companies.

Copyright Notice

The works of authorship contained in this manual, including, but not limited to, all designs, text, and images are owned by Chauvet.

© Copyright 2024 Chauvet & Sons, LLC. All rights reserved.

Electronically published by Chauvet in the United States of America.

Manual Use

Chauvet authorizes its customers to download and print this manual for professional information purposes only. Chauvet expressly prohibits the usage, copy, storage, distribution, modification, or printing of this manual or its content for any other purpose without written consent from Chauvet.

Document Printing

For best results, print this document in color, on letter size paper (8.5 x 11 in), double-sided. If using A4 paper (210 x 297 mm), configure the printer to scale the content accordingly.

Intended Audience

Any person installing, operating, and/or maintaining this product should completely read through the guide that shipped with the product, as well as this manual, before installing, operating, or maintaining this product.

Disclaimer

Chauvet believes that the information contained in this manual is accurate in all respects. However, Chauvet assumes no responsibility and specifically disclaims any and all liability to any party for any loss, damage, or disruption caused by any errors or omissions in this document, whether such errors or omissions result from negligence, accident, or any other cause. Chauvet reserves the right to revise the content of this document without any obligation to notify any person or company of such revision, however, Chauvet has no obligation to make, and does not commit to make, any such revisions.

Document Revision

Go to www.chauvetprofessional.com for the latest version.

Revision	Date	Description
1	07/2024	Initial release

TABLE OF CONTENTS

- 1. Before You Begin** 1
 - What Is Included 1
 - Claims 1
 - Text Conventions 1
 - Symbols 1
 - Safety Notes..... 2
 - FCC Statement of Compliance 3
 - RF Exposure Warning for North America and Australia..... 3
 - Expected LED Lifespan..... 3
- 2. Introduction** 4
 - Description 4
 - Features 4
 - Product Overview 5
 - Product Dimensions 6
- 3. Setup** 7
 - AC Power 7
 - AC Plug 7
 - Fuse Replacement 7
 - Signal Connections 8
 - Control Personalities 8
 - DMX Linking 8
 - Art-Net™ Connection 8
 - sACN Connection..... 8
 - Remote Device Management..... 8
 - Connection Diagram 9
 - USB Software Update 9
- 4. Operation** 10
 - Control Panel Description 10
 - Battery-Powered Display..... 10
 - Home Screen 10
 - Control Panel Lock..... 10
 - Passcode 10
 - Technician Mode..... 10
 - Menu Map 11
 - Control Configuration 18
 - Control Mode..... 18
 - Control Personalities 18
 - Starting Address..... 19
 - Network Setup..... 19
 - IP Mode..... 19
 - Manual IP Address 19
 - Subnet Mask 19
 - Control Channel Assignments and Values..... 20
 - Pixel Chart..... 20
 - Single Control Values..... 21

Dual Control Movement Values	44
Dual Control Pixels Values.....	46
Color Chart.....	53
Strobe Chart.....	53
Control Chart.....	54
Settings Configuration.....	55
Pan Reverse	55
Tilt Reverse	55
Zoom Reverse.....	55
Screen Reverse	55
Pan Angle.....	55
Tilt Angle	55
Black out on Movement.....	55
Swap Pan and Tilt.....	55
Lock Screen	55
WDMX Reset	55
Display Backlight Timer.....	56
Loss of Data	56
Fan Speed.....	56
Color Mixing Mode	56
Dimmer Curve	56
Dimmer Speed	56
Pulse Width Modulation	56
Color Balance.....	56
Calibrated White.....	56
White Balance	57
Merge Channel.....	57
Preset Select.....	57
Preset Sync.....	57
USB Update	57
TV Reset Mode	57
Reset function	57
Factory Reset.....	58
Test Mode	58
Auto Test.....	58
Manual Test	58
System Information	58
Offset Mode.....	58
Web Server	59
5. Maintenance.....	60
Product Maintenance	60
Torque Measurements	60
Vacuum Test Measurements	60
Transporting on Truss or Racks.....	61
6. Technical Specifications	62
Contact Us	63
Warranty & Returns.....	63

Before You Begin

1. Before You Begin

What Is Included

- Maverick Storm 3 BeamWash
- Seetronic Powerkon IP65 power cable to bare wire
- (2) 140 D Omega brackets with mounting hardware
- Quick Reference Guide

Claims

Carefully unpack the product immediately and check the container to make sure all the parts are in the package and are in good condition.



If the box or the contents (the product and included accessories) appear damaged from shipping, or show signs of mishandling, notify the carrier immediately, not Chauvet. Failure to report damage to the carrier immediately may invalidate a claim. In addition, keep the box and contents for inspection.

For other issues, such as missing components or parts, damage not related to shipping, or concealed damage, file a claim with Chauvet within 7 days of delivery.

Text Conventions

Convention	Meaning
1–512	A range of values
50/60	A set of values of which only one can be chosen
Settings	A menu option not to be modified
<ENTER>	A key to be pressed on the product's control panel

Symbols

Symbol	Meaning
	Critical installation, configuration, or operation information. Not following these instructions may make the product not work, cause damage to the product, or cause harm to the operator.
	Important installation or configuration information. The product may not function correctly if this information is not used.
	Useful information.



Any reference to data or power connections in this manual assumes the use of Seetronic IP-rated cables.



The term “DMX” used throughout this manual refers to the USITT DMX512-A digital data transmission protocol.

Connection of the control signal: DMX line

- The product has XLR sockets for DMX input and output.
- Notice: This control circuit is isolated and belongs to the Class 2 data port.

The control circuit has a cumulative leakage current of less than 3.5 mA.

Safety Notes

Read all the following safety notes before working with this product. These notes contain important information about the installation, usage, and maintenance of this product.



This product contains no user-serviceable parts. Any reference to servicing in this User Manual will only apply to properly trained, certified technicians. Do not open the housing or attempt any repairs.



All applicable local codes and regulations apply to proper installation of this product.

- The luminaire is intended for professional use only.
- The luminaire should be positioned so that prolonged staring into the luminaire at a distance closer than 32.8 ft (10 m) is not expected.
- If the external flexible cable or cord of this luminaire is damaged, it shall be replaced by a special cord or cord exclusively available from the manufacturer or its service agent.
- The light source contained in this luminaire shall only be replaced by the manufacturer or its service agent or a similar qualified person.
- **CAUTION:**
 - This product's housing may be hot when operating. Mount this product in a location with adequate ventilation, at least 20 in (50 cm) from adjacent surfaces.
 - When transferring the product from extreme temperature environments, (e.g., cold truck to warm humid ballroom) condensation may form on the internal electronics of the product. To avoid causing a failure, allow the product to fully acclimate to the surrounding environment before connecting it to power.
 - Flashing light is known to trigger epileptic seizures. User must comply with local laws regarding notification of strobe use.
- **ALWAYS:**
 - Disconnect from power before cleaning the product or replacing the fuse.
 - When using an IP65-rated product in an outdoor environment, use IP65- (or higher) rated power and data cable.
 - Replace and secure IP-rated protective covers to all power, data, USB, or other ports when not in use.
 - Replace the fuse with the same type and rating.
 - Use a safety cable when mounting this product overhead.
 - Connect this product to a grounded and protected circuit.
- **DO NOT:**
 - Open this product. It contains no user-serviceable parts.
 - Look at the light source when the product is on.
 - Leave any flammable material within 200 cm of this product while operating or connected to power.
 - Connect this product to a dimmer or rheostat.
 - Operate this product if the housing, lenses, or cables appear damaged.
 - Submerge this product (adhere to standards for the published IP rating). Regular outdoor operation is fine.
 - Permanently install outdoors in locations with extreme environmental conditions. This includes, but is not limited to:
 - Exposure to a marine/saline environment (within 3 miles of a saltwater body of water).
 - Locations where normal temperatures exceed the temperature ranges in this manual.
 - Locations that are prone to flooding or being buried in snow.
 - Other areas where the product will be subject to extreme radiation or caustic substances.
- **ONLY** use the hanging/mounting bracket to carry this product.
- The maximum ambient temperature is 113 °F (45 °C). Do not operate this product at higher temperatures.
- The minimum startup temperature is -4°F (-20°C). Do not start the product at lower temperatures.
- To eliminate unnecessary wear and improve its lifespan, during periods of non-use completely disconnect the product from power via breaker or by unplugging it.
- In the event of a serious operating problem, stop using immediately.



If a Chauvet product requires service, contact Chauvet Technical Support.

Before You Begin

FCC Statement of Compliance

This device complies with Part 15 Part B of the FCC rules. Operation is subject to the following two conditions:

1. This device may not cause harmful interference, and
2. This device must accept any interference received, including interference that may cause undesired operation.

This equipment has been tested and found to comply with the limits for a Class B digital device, pursuant to Part 15 of the FCC Rules. These limits are designed to provide reasonable protection against harmful interference in a residential installation. This equipment generates uses and can radiate radio frequency energy and, if not installed and used in accordance with the instructions, may cause harmful interference to radio communications. However, there is no guarantee that interference will not occur in a particular installation. If this equipment does cause harmful interference to radio or television reception, which can be determined by turning the equipment off and on, the user is encouraged to try to correct the interference by one or more of the following measures:

- Reorient or relocate the receiving antenna.
- Increase the separation between the equipment and receiver.
- Connect the equipment into an outlet on a circuit different from that to which the receiver is connected.
- Consult the dealer or an experienced radio/TV technician for help.

Any changes or modifications not expressly approved by the party responsible for compliance could void the user's authority to operate the equipment.

RF Exposure Warning for North America and Australia

Warning! This equipment complies with FCC radiation exposure limits set forth for an uncontrolled environment. This equipment should be installed and operated with a minimum distance of 20 cm between the radiator and the user. This transmitter must not be co-located or operating in conjunction with any other antenna or transmitter.

Expected LED Lifespan

Over time, use and heat will gradually reduce LED brightness. Clustered LEDs produce more heat than single LEDs, contributing to shorter lifespans if always used at full intensity. The average LED lifespan is 40,000 to 50,000 hours. To extend LED lifespan, maintain proper ventilation around the product, and limit the overall intensity.

2. Introduction

Description

The Maverick Storm 3 BeamWash creates new possibilities with two zones of zoom control. Both zones independently zoom from 4.6° to 53.6°, allowing beam and wash combinations from a single fixture. A 16-lens outer zone and 12-lens inner zone combine to deliver a 19,062 lumens output from 28 x 45W RGBW LEDs. Built-in macros with foreground and background control generate stunning pixel eye candy and a unique lens design delivers color blending, tight aerial beam effects, and visual impact live or on camera. Dual mode operation enables pixel-mapped eye candy to run under ArtNet/sACN control with separate assignment of motorized functions to DMX. Housed in an advanced IP65-rated alloy body, Maverick Storm 3 BeamWash is built with the durability and versatility to perform in any venue.

Features

- Full-featured, compact IP65 BeamWash with (28) 45 w RGBW LEDs that zoom down to 3.9 degrees to produce powerful, tight aerial beams and out to 53.8degrees for wide washes and individual pixel control for stunning eye candy effects with two independent zones of zoom control along with a (256) LED ring with 12 zones of control for even more eye candy effects.
- 3.9° to 53.8°zoom range in both zoom zones
- 12 zone pixel-mappable RGB LED outer ring under a stealth filter for added effect possibilities
- Incredibly bright! Over 18,500 lumens!
- Fully pixel mappable LEDs
- Built in LED macros with foreground and background control for easy generation of pixel effects
- Unique lens design for excellent color blending and tight beam effects
- Fast, smooth pan and tilt movement
- User selectable full output 7500K calibrated white
- Selectable PWM settings for camera operation
- 6 distinct dimming modes for advanced control
- Simple and complex DMX channel profiles for programming versatility including dual mode operation.
- 5-pin DMX and EtherCON input/output connections
- RDM Enabled for remote addressing & trouble shooting
- Easy to read OLED display with simple, effective menu options
- USB-C port for convenient software uploads
- Easily accessible web server for testing and setting fixture functions
- Removable handles on the arms make moving the fixture easy.
- Failsafe Ethernet connectivity allows for data to pass even if fixture power is lost

Product Overview

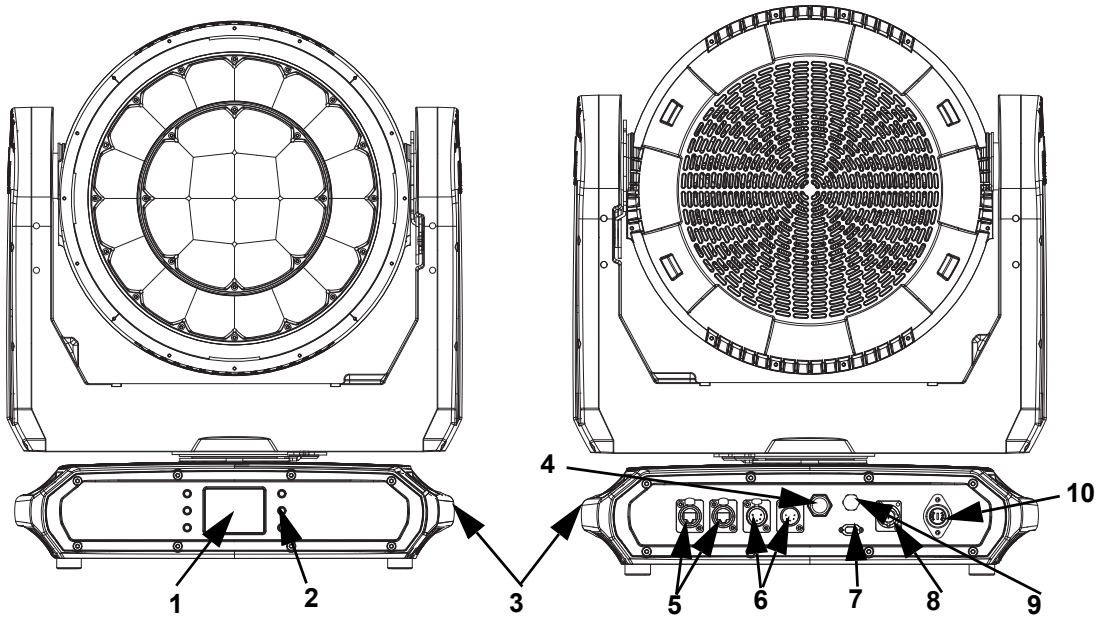

#	Name	#	Name
1	LCD display	6	DMX in/out
2	Menu buttons	7	USB port
3	Carry handle	8	Power in
4	WDMX antenna	9	Condensation port
5	Ethernet port	10	Fuse holder

Product Dimensions

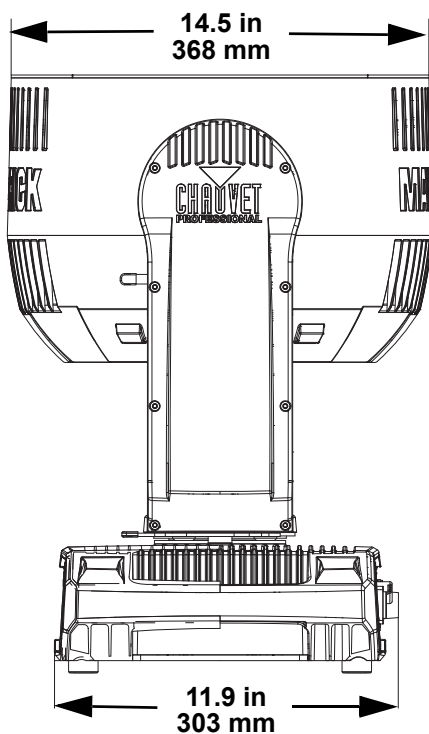
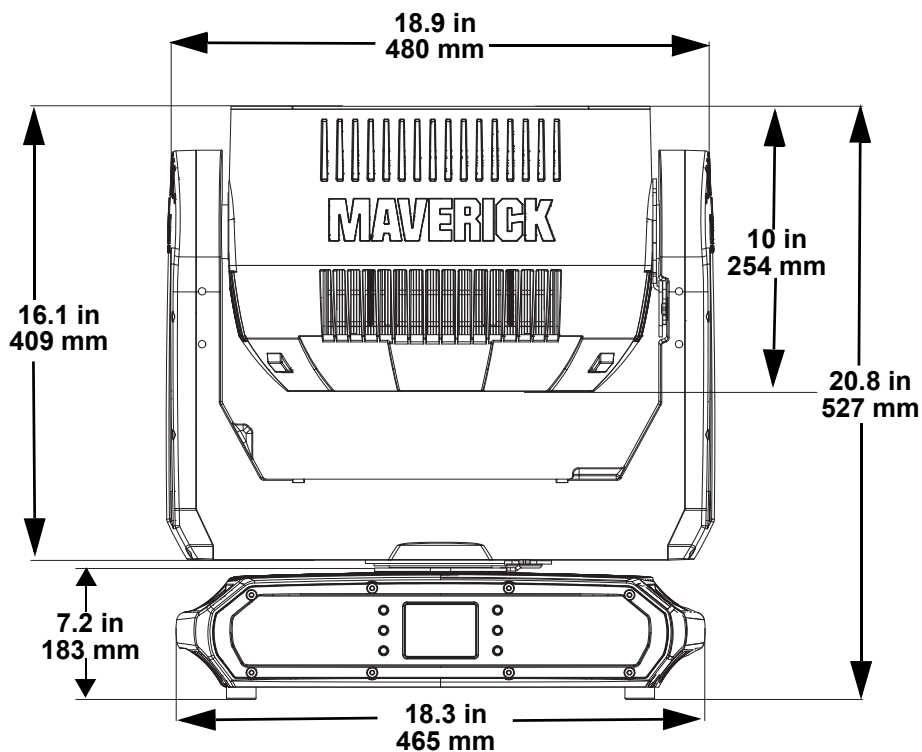

3. Setup

AC Power

The Maverick Storm 3 BeamWash has an auto-ranging power supply, and it can work with an input voltage range of 100 to 240 VAC, 50/60 Hz.

To determine the product's power requirements (circuit breaker, power outlet, and wiring), use the current value listed on the label affixed to the product's back panel, or refer to the product's specifications chart.

The listed current rating indicates the product's average current draw under normal conditions.



- **Always connect the product to a protected circuit (a circuit breaker or fuse). Make sure the product has an appropriate electrical ground to avoid the risk of electrocution or fire.**
- **To eliminate unnecessary wear and improve its lifespan, during periods of non-use completely disconnect the product from power via breaker or by unplugging it.**



Never connect the product to a rheostat (variable resistor) or dimmer circuit, even if the rheostat or dimmer channel serves only as a 0 to 100% switch.

AC Plug

The Maverick Storm 3 BeamWash comes with a power input cable terminated with a Seetronic Powerkon A connector and bare end on the other end (U.S. market). Use the table below to wire a plug.

Connection	Wire (U.S.)	Wire (Europe)	Screw Color
AC Live	Black	Brown	Yellow or Brass
AC Neutral	White	Blue	Silver
AC Ground	Green/Yellow	Green/Yellow	Green

Fuse Replacement

1. Disconnect this product from the power outlet.
2. Using a flat-head screwdriver, unscrew the fuse holder cap from the housing.
3. Remove the blown fuse and replace with another fuse of the same type and rating (T25 A, 750 V).
4. Screw the fuse holder cap back in place and reconnect power.

Signal Connections

The Maverick Storm 3 BeamWash can receive a DMX, Art-Net™, or sACN, signal. The Maverick Storm 3 BeamWash has two Amphenol XLRnet through ports and 5-pin DMX in and out ports. If using other compatible products with this product, it is possible to control each individually with a single controller.

Control Personalities

The Maverick Storm 3 BeamWash uses a 5-pin DMX data connection, WDMX, Art-Net™, Kling-Net, or sACN for its control personalities:

Single Control	Dual Control Movement	Dual Control Pixels
Basic (32-channel)	Basic (12-channel)	Basic (120-channel)
Standard (180-channel)	Standard (35-channel)	Standard (148-channel)
Advanced (336-channel)	Advanced (46-channel)	Advanced (296-channel)
Tour (416-channel)		
Basic2 (38-channel)		
Busk (20-channel)		
Basic3 (38-channel)		
Full PXL (424-channel)		

- Refer to the [Operation](#) chapter to learn how to configure the Maverick Storm 3 BeamWash to work in these personalities.
- The [Control Channel Assignments and Values](#) section provides detailed information regarding the control personalities.



For more information about DMX standards or the DMX cables needed to link this product to a DMX controller, download the DMX Primer from the Chauvet website: www.chauvetprofessional.com.

DMX Linking

The Maverick Storm 3 BeamWash can link to a DMX controller using a 5-pin DMX connection or a WDMX connection. For more information about DMX, read the DMX primer at:

https://www.chauvetprofessional.com/wp-content/uploads/2016/06/DMX_Primer.pdf.

Art-Net™ Connection

Art-Net™ is an Ethernet protocol that uses TCP/IP that transfers a large amount of DMX512 data using an Neutrik IP-rated RJ45 connection over a large network. An Art-Net™ protocol document is available from www.chauvetprofessional.com.

Art-Net™ designed by and copyright Artistic Licence Holdings Ltd.

sACN Connection

Streaming ACN (Architecture for Control Networks), also known as ANSI E1.31, is an Ethernet protocol that uses the layering and formatting of ACN to transport DMX512 data over IP or any other ACN-compatible network.

Remote Device Management

Remote Device Management (RDM) is a standard for allowing DMX-enabled devices to communicate bi-directionally along existing DMX cabling. Check the DMX controller's User Manual or with the manufacturer, as not all DMX controllers have this capability. The Maverick Storm 3 BeamWash supports RDM protocol that allows feedback to make changes to menu map options.

Connection Diagram

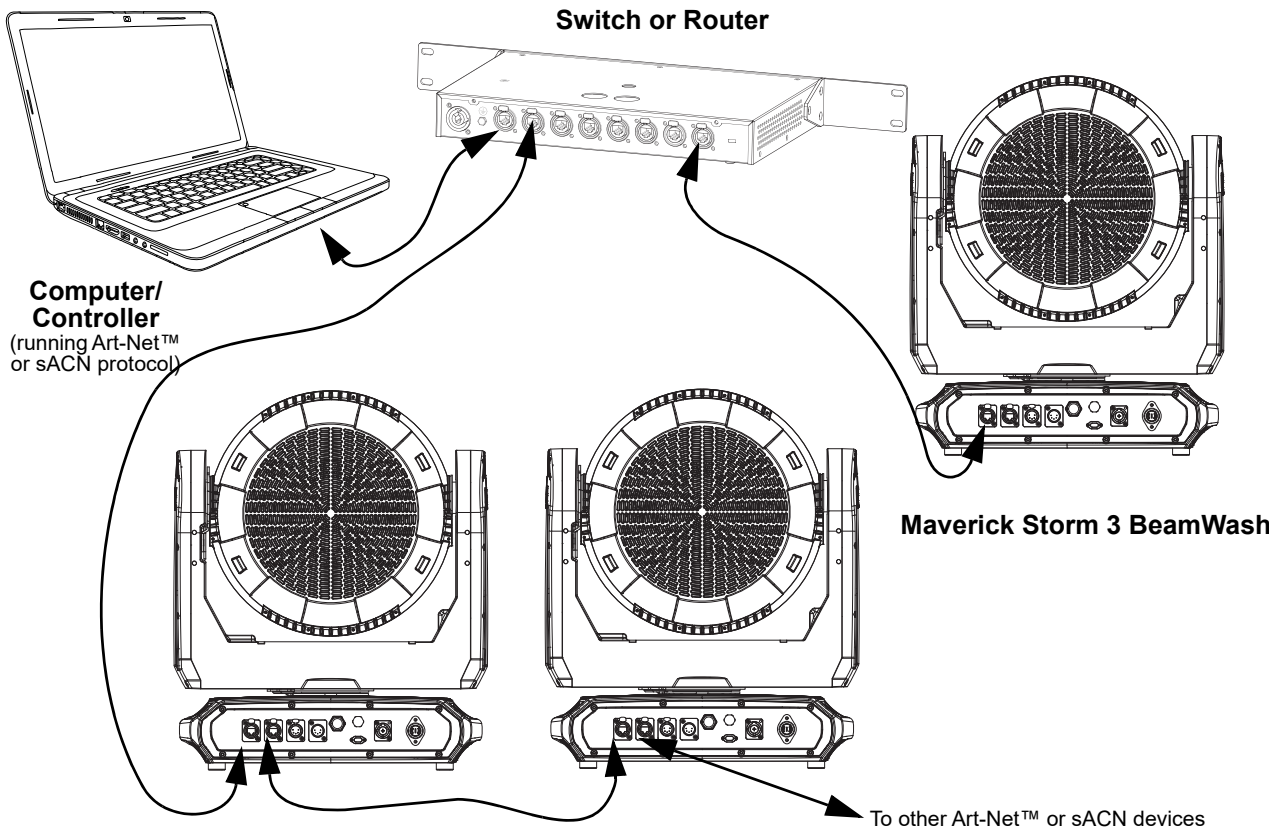

USB Software Update

The Maverick Storm 3 BeamWash allows for software updates with a USB device using the built-in USB port. To update the software using a USB flash drive, do the following:

1. Power on the product, and plug the flash drive into the USB port.
2. Once the flash drive has been detected, the message "USB UPDATE" will be displayed. Select **YES**.
3. The next screen will show the software versions available for this fixture on the USB drive. For multiple versions of the software for the same fixture, use <UP> or <DOWN> to select the desired version. Press <ENTER>.
4. The "USB UPDATE" screen will re-appear. Select **YES**.



It is possible to update multiple units with the USB if they are daisy chained via DMX.

5. The upgrade will start. **DO NOT** turn off the power or disconnect the USB while the USB LED is still blinking during the process. The screen display will read: "USB Update Wait". The update can take several minutes to complete.
 - When the USB firmware is done uploading, in some fixtures, the display will change to: "DO NOT UNPLUG, UPDATING".
6. When the update is completed, the fixture will automatically reboot.
7. Go to Fixture Information on the product's menu map and confirm the firmware revision.
8. When the boot-up process is finished, restart the product.









- Place the .chl file in the root directory of the USB drive.
- The product's USB port supports up to 32GB capacity and only works with FAT32 file format.



Turning off the power or removing the USB while the USB LED is still blinking during the update will cause partial or total firmware failure in the targeted fixture(s). If this occurs, the user will need the UPLOAD 08 device to fix this. Please contact Chauvet regarding this device.

4. Operation

Control Panel Description

Button	Name	Function
	<UP>	Navigates upwards through the menu list or increases the value when in a function
	<MENU>	Exits from the current menu or function
	<DOWN>	Navigates downwards through the menu list or decreases the value when in a function
	<LEFT>	Navigates leftwards through the menu list
	<ENTER>	Enables the currently displayed menu or sets the selected value into the function
	<RIGHT>	Navigates rightwards through the menu list

Battery-Powered Display

The Maverick Storm 3 BeamWash has a battery-powered display that enables access to the menu when the product is powered off. Press and hold <MENU> until the display activates (approximately 15 seconds).

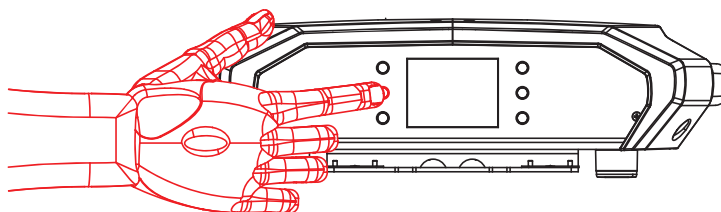

Home Screen

The Maverick Storm 3 BeamWash has a home screen that shows the current control protocols, personalities, starting addresses, IP addresses, and universes. To see the home screen, press <MENU> repeatedly until it shows on the display. From the home screen, touch any of the displayed control settings to immediately jump to that part of the menu, such as the personality, starting address, or universe, or press <ENTER> to reach the main menu.

Control Panel Lock

The setting locks or unlocks the control panel.

1. Go to the **Settings** main level.
2. Select the **Lock Screen** option.
3. Select **NO** (control panel stays unlocked) or **YES** (locks control panel).



When the control panel lock is activated, the product will prompt for the passcode in order to access the menu. Enter the passcode as described below.

Passcode

After being prompted to enter the passcode, enter the numbers **0920**.

Technician Mode

The technician mode disables the pan/tilt motors, allowing the output of the product to be aimed by hand. To enable the technician mode of the Maverick Storm 3 BeamWash, hold <UP> and <LEFT> while the product is powering on. When the product is turned off and back on, the pan and tilt will return to normal function.

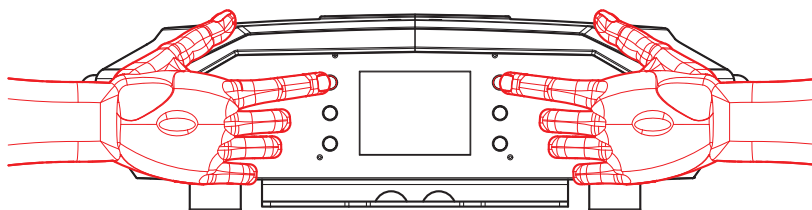

Menu Map

Refer to the Maverick Storm 3 BeamWash product page on www.chauvetprofessional.com for the latest menu map.

Programming Levels				Description	
Control Settings	Control Settings			Control Settings Main Level	
	Single Control	DMX	Personality	Basic	Sets the DMX personality: (see Control Personalities)
				Standard	
				Advanced	
				Tour	
				Basic 2	
				Busk	
				Basic 3	
				Full PXL	
		Start Address	001–512	Sets the DMX starting address	
		ArtNet	Personality	Basic	Sets the Art-Net™ personality: (see Control Personalities)
				Standard	
				Advanced	
				Tour	
				Basic 2	
	Busk				
	Basic 3				
	Full PXL				
	Start Address	001–512	Sets the Art-Net™ starting address		
	Universe	000–255	Sets the Art-Net™ universe		
	sACN	Personality	Basic	Sets the sACN personality: (see Control Personalities)	
			Standard		
			Advanced		
			Tour		
			Basic 2		
			Busk		
			Basic 3		
			Full PXL		
Start Address		001–512	Sets the sACN starting address		
Universe		001–256	Sets the sACN universe		
WDMX	Personality	Basic	Sets the WDMX personality (see Control Personalities)		
		Standard			
		Advanced			
		Tour			
		Basic 2			
		Busk			
		Basic 3			
		Full PXL			
	Start Address	001–512	Sets the WDMX address		

Programming Levels					Description	
Control Settings	Dual Control	Movement	DMX	Personality	Basic	Sets the DMX personality: (see Control Personalities)
				Standard		
				Advanced		
			Start Address	1–512	Sets the DMX starting address	
			ArtNet	Personality	Basic	Sets the Art-Net™ personality: (see Control Personalities)
					Standard	
		Advanced				
		Start Address		1–512	Sets the Art-Net™ starting address	
		Universe	0–255	Sets the Art-Net™ universe		
		sACN	Personality	Basic	Sets the sACN personality: (see Control Personalities)	
				Standard		
				Advanced		
	Start Address	1–512	Sets the sACN starting address			
	Universe	1–256	Sets the sACN universe			
	Pixels	DMX	Personality	Basic	Sets the DMX personality (see Control Personalities)	
				Standard		
				Advanced		
			Start Address	001–512	Sets the DMX starting address	
			ArtNet	Personality	Basic	Sets the Art-Net™ personality: (see Control Personalities)
					Standard	
		Advanced				
		Start Address		001–512	Sets the Art-Net™ starting address	
		Universe	000–255	Sets the Art-Net™ universe		
		sACN	Personality	Basic	Sets the sACN personality: (see Control Personalities)	
Standard						
Advanced						
Start Address	1–512		Sets the sACN starting address			
Universe	0–255	Sets the sACN universe				
Kling-Net	Personality	Basic	Sets the Kling-Net personality: (see Control Personalities)			
		Standard				

Main Level	Programming Levels		Description	
Test Mode	Auto Test		Auto test all functions	
	Manual Test	Pan	000-255	Manually control and test all settings through the control panel
		Tilt		
		P/T Speed		
		Red1		
		Green1		
		Blue1		
		CTC1		
		Color1		
		Pattern1		
		LED Macro1		
		LED Ma. Speed1		
		LED Ma. Fade1		
		Background1		
		Background1 Dim.		
		Dimmer1		
		Shutter1		
		Red2		
		Green2		
		Blue2		
		White2		
		CTC2		
		Color2		
		Pattern2		
		LED Macro2		
		LED Ma. Speed2		
		LED Ma. Fade2		
		Background2		
		Background2 Dim		
		Dimmer2		
Shutter2				
Control				
Zoom1				
Zoom2				

Main Level	Programming Levels		Description	
Setup	Network Setting	IP Mode	Manual	Manually set IP address
			DHCP	Network sets IP address
			Static	Product sets IP address
		IP	---'---'---	Sets IP address in Manual mode
		SubMask	---'---'---	Sets Subnet Mask in Manual mode
	Pan Reverse		NO	Normal pan
			YES	Reversed pan
	Tilt Reverse		NO	Normal tilt
			YES	Reversed tilt
	Zoom Reverse		NO	Normal zoom
			YES	Reversed zoom
	Screen Reverse		NO	Normal display
			YES	Inverted display
			AUTO	Automatic display orientation
	Pan Angle		540	540° pan range
			360	360° pan range
			180	180° pan range
	Tilt Angle		260	260° tilt range
			180	180° tilt range
			90	90° tilt range
	BL. O. P/T Move		NO	Do not black out while pan/tilt
			YES	Blackout while pan/tilt
	Swap XY		NO	Do not swap pan and tilt
			YES	Pan controls tilt, tilt controls pan
	Lock Screen		NO	Lock the buttons and touch screen
			YES	Passcode: 0920
	WDMX Reset		NO	Do not reset WDMX
			YES	Reset WDMX
	Backlight Timer		30S	Display turns off after 30 seconds
			1M	Display turns off after 1 minute
			5M	Display turns off after 5 minutes
			ON	Display stays on
Loss of Data		Hold	Holds last signal received	
		Close	Blacks out fixture	
Fans		Auto	Fan speed according to product temperature	
		Full	Fan speed set on high	
		ECO	Quiet mode	
C Mixing Mode		RGBW	RGBW mode	
		CMY	CMY mode (R=C, G=M, B=Y)	
Dimmer Curve		Linear	Set the dimmer curve	
		Square		
		I Squa		
		SCurve		
Dimmer Speed		Smooth	Set the dimmer speed	
		Fast		
PWM Option		600Hz	Define Pulse Width Modulation setting	
		1200Hz		
		2000Hz		
		4000Hz		
		15000Hz		

Operation



Main Level	Programming Levels		Description	
Setup (cont.)	Color Balance	Red	100–255	Sets red LED maximum value
		Green		Sets green LED maximum value
		Blue		Sets blue LED maximum value
		White		Sets white LED maximum value
	Calibrated White	ON		Calibrated white balance
		OFF		Uses maximum white values
		Custom		Uses custom white balance
	White Balance	Red	000–255	Sets red LED maximum value
		Green		Sets green LED maximum value
		Blue		Sets blue LED maximum value
		White		Sets white LED maximum value
	Merge Channel	NO		Merge zoom function
		YES		
	Preset Select	PRESET A		Recorded preset menu options
		PRESET B		
		PRESET C		
	Preset Sync	NO		Allows recorded preset menu options to be transferred to other Maverick Storm 3 BeamWash products in the DMX daisy chain
YES				
USB Update	NO		Update firmware via USB-C	
	YES			
TV Reset Mode	NO		enable/disable TV mode	
	Yes			
Reset Function	Pan/Tilt	NO	Reset individual functions or all functions from start-up	
		YES		
	Zoom	NO		
		YES		
	All	NO		
		YES		
Factory Settings	NO		Reset to factory default settings	
	YES			

Main Level	Programming Levels		Description	
Sys Info	Fixture Information	Ver	V_ _ _ _ _ _ _	Shows firmware version
		Running Mode	_ _ _ _	Shows current running mode
		Address	_ _ _ _	Shows current starting address
		Temperature	_ _ _ _	Shows current product temperature in °C
		Fixture Hours	_ _ _ _ _	Shows number of hours product has been powered on
		Ip	_ _ . _ _ . _ _ . _ _	Shows current IP address
		SubMask	_ _ _ . _ _ _ . _ _ _	Shows current Subnet Mask
		MAC	_ _ : _ _ : _ _ : _ _ : _ _ : _ _	Shows current MAC address
	LED Hours	_ _ _ _ _	Shows number of hours LEDs have been powered on	
	Fan Information	Head Fan1 Speed	_ _ _ _ _	Shows speed of head fans in rpm
		Head Fan2 Speed	_ _ _ _ _	
		Head Fan3 Speed	_ _ _ _ _	
		Head Fan4 Speed	_ _ _ _ _	
		Head Fan5 Speed	_ _ _ _ _	
		Head Fan6 Speed	_ _ _ _ _	
DEFROST XFAN2		_ _ _ _ _		
XFAN3 Speed		_ _ _ _ _		
Base Fan1 Speed		_ _ _ _ _		
Base Fan2 Speed		_ _ _ _ _		
Base Fan3 Speed		_ _ _ _ _		
Base Fan4 Speed		_ _ _ _ _		
Error Information	No Error!*		Shows any errors, or No Error!	

Main Level	Programming Levels		Description
<p>Sys Info (cont.)</p>	<p>Channel Information</p>	<p>Frequency</p> <p>Pan</p> <p>Pan Fine</p> <p>Tilt</p> <p>Tilt Fine</p> <p>P/T Speed</p> <p>CTC</p> <p>Color</p> <p>Pattern</p> <p>LED Macro</p> <p>LED Ma. Speed</p> <p>LED Ma. Fade</p> <p>Background</p> <p>Background Dim.</p> <p>Big. Dim. Fine</p> <p>Dimmer</p> <p>Dimmer Fine</p> <p>Bg. Dim. Fine</p> <p>Dimmer</p> <p>Dimmer Fine</p> <p>Shutter</p> <p>Zoom1</p> <p>Zoom2</p> <p>Control</p> <p>Red</p> <p>Red Fine</p> <p>Green</p> <p>Green Fine</p> <p>Blue</p> <p>Blue Fine</p> <p>White</p> <p>White Fine</p> <p>Dimmer (all, 1–28)</p> <p>Dimmer Fine (all, 1–28)</p> <p>Red (all, 1–28)</p> <p>Red Fine (all, 1–28)</p> <p>Green (all, 1–28)</p> <p>Green Fine (all, 1–28)</p> <p>Blue (all, 1–28)</p> <p>Blue Fine (all, 1–28)</p> <p>White (all, 1–28)</p> <p>White Fine (all, 1–28)</p>	<p>---</p> <p>Shows all current values from input signals, 000–255</p>

Control Configuration

Use control configurations to operate the product with a DMX, WDMX, Art-Net™, Kling-Net, and sACN control signals.

Control Mode

The Maverick Storm 3 BeamWash works with wired DMX, WDMX, Art-Net™, Kling-Net, and sACN control signals. To select which single control protocol to use:

1. Go to the **Control Settings** main level.
2. Select the **Single Control** option
3. Select the desired protocol, from **DMX**, **ArtNet**, **sACN**, or **WDMX**.

To select which dual control protocol to use:

1. Go to the **Control Settings** main level.
2. Select the **Dual Control** option
 1. Select either **Movement** (select from **DMX**, **ArtNet**, or **sACN**) or **Pixels** (select from **DMX**, **ArtNet**, or **KlingNet**).



In Dual Control mode, the Movement protocol and the Pixels protocol cannot be the same.



- See the [WDMX Reset](#) section for further setup of WDMX.
- See the [Network Setup](#) section for further setup of ethernet protocols (Art-Net™ or sACN).

Control Personalities

To set the control personality:

1. Select the **Personality** option.
2. Select the desired personality, from:

Single Control	Dual Control Movement	Dual Control Pixels
Basic (32-channel)	Basic (12-channel)	Basic (120-channel)
Standard (180-channel)	Standard (35-channel)	Standard (148-channel)
Advanced (336-channel)	Advanced (46-channel)	Advanced (296-channel)
Tour (416-channel)		
Basic2 (38-channel)		
Busk (20-channel)		
Basic3 (38-channel)		
Full PXL (424-channel)		



- See the [Starting Address](#) section for the highest selectable starting address for each personality.
- **Make sure that the starting addresses on the various products do not overlap due to the new personality setting.**

Operation

Starting Address

Each product will respond to a unique starting address from the controller. All products with the same starting address will respond in unison.

To set the starting address in Single Control mode:

1. Go to the **Address Setting** level.
2. Select the starting address (**001–512**).

Control Mode	Personality	Channels	Highest Address
Single Control	Basic	32	481
	Standard	180	333
	Advanced	336	177
	Tour	416	97
	Basic2	38	475
	Busk	20	493
	Basic 3	38	475
	Full PXL	424	89
Dual Control Movement	Basic	12	501
	Standard	35	478
	Advanced	46	467
Dual Control Pixels	Basic	120	393
	Standard	148	365
	Advanced	296	217

Network Setup

The Network Setup settings control the IP address, subnet mask, and universe of the product.

IP Mode

To choose how the IP address is set:

1. Go to the **Network Setting** level.
2. Select the **IP Mode** option.
3. Select the desired IP mode, from **Manual** (to set a custom IP address), **DHCP** (the IP address is assigned by the connected network), or **Static** (the product uses a default, preset IP address).

Manual IP Address

To set the IP address when the **IP Mode** is set to **Manual**:

1. Go to the **Network Setting** level.
2. Select the **Ip** option.
3. Set the 4 values of the IP address from **000–255**.

Subnet Mask

To set the subnet mask:

1. Go to the **Network Setting** level.
2. Select the **SubMask** option.
3. Set the 4 values of the subnet mask from **000–255**.

Control Channel Assignments and Values

Pixel Chart

Main

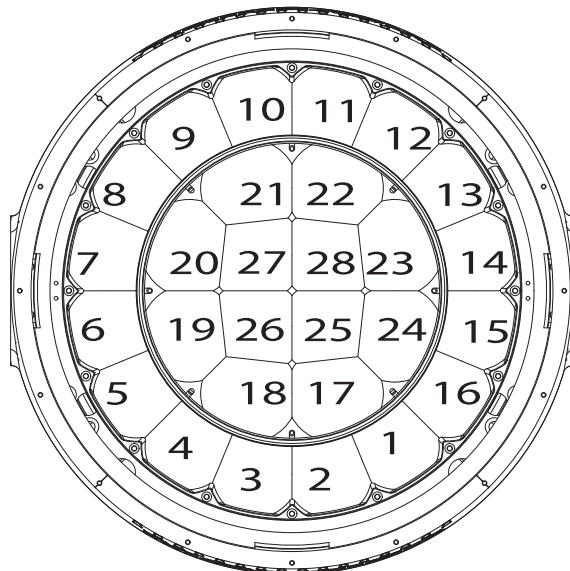

Ring Chart

Ring

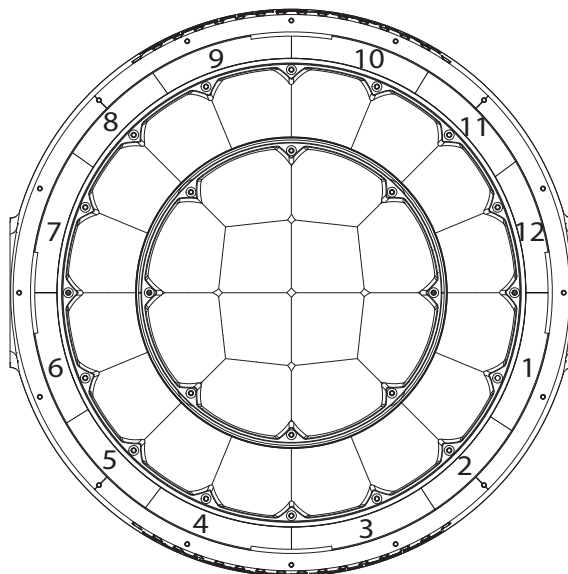

Operation

Single Control Values

BK: Busk (20 channels)

Channel	Function	Value	Percent/Setting
1	Pan	000 ⇔ 255	0–100%
2	Tilt	000 ⇔ 255	0–100%
3	Pan/tilt speed	000 ⇔ 255	0–100%
4	Dimmer (main)	000 ⇔ 255	0–100%
5	Strobe (main)	000 ⇔ 255	See Strobe Chart
6	Red/cyan	000 ⇔ 255	0–100%
7	Green/magenta	000 ⇔ 255	0–100%
8	Blue/yellow	000 ⇔ 255	0–100%
9	White	000 ⇔ 255	0–100%
10	CTC (ring)	000 ⇔ 255	0–100%
11	Auto program (ring)	000 ⇔ 005	No function
		006 ⇔ 215	Auto programs 1-42
		216 ⇔ 255	No function
12	Auto program speed (ring)	000 ⇔ 127	Clockwise, fast to slow
		128	Stop
		129 ⇔ 215	Counterclockwise, slow to fast
13	Dimmer (ring)	000 ⇔ 255	0–100%
14	Strobe (ring)	000 ⇔ 255	See Strobe Chart
15	Color macros (main)	000 ⇔ 255	See Color Chart
16	Auto program (main)	000 ⇔ 015	No function
		016 ⇔ 255	Auto programs
17	Auto program speed (main)	000 ⇔ 127	Clockwise, fast to slow
		128	Stop
		129 ⇔ 215	Counterclockwise, slow to fast
18	Zoom 1	000 ⇔ 255	Wide to narrow
19	Zoom 2	000 ⇔ 255	Wide to narrow
20	Control	000 ⇔ 255	See Control Chart

B: Basic (32 channels), **B2:** Basic 2 (38 channels), **B3:** Basic 3 (38 channels)

B	B2	B3	Function	Value	Percent/Setting
1	1	1	Pan	000 ⇔ 255	0–100%
2	2	2	Pan fine	000 ⇔ 255	0–100%
3	3	3	Tilt	000 ⇔ 255	0–100%
4	4	4	Tilt fine	000 ⇔ 255	0–100%
5	5	5	Pan/tilt speed	000 ⇔ 255	0–100%
6	6	6	CTC (ring)	000 ⇔ 255	0–100%
7	7		CTC (main)	000 ⇔ 255	0–100%
8	8	7	Color macros (ring)	000 ⇔ 255	See Color Chart
9	9	8	Color macros (main)	000 ⇔ 255	See Color Chart
10	10	9	Pattern (ring)	000 ⇔ 004	No function
				005 ⇔ 255	Color macros
11	11	–	Pattern (main)	000	No function
				001 ⇔ 255	Color macros
12	12	10	Auto program (ring)	000 ⇔ 005	No function
				006 ⇔ 215	Auto programs 1-42
				216 ⇔ 255	No function
13	13	11	Auto program speed (ring)	000 ⇔ 127	Clockwise, fast to slow
				128	Stop
				129 ⇔ 215	Counterclockwise, slow to fast
15	15	–	Auto program (main)	000 ⇔ 015	No function
				016 ⇔ 255	Auto programs
16	16	–	Auto program speed (main)	000 ⇔ 127	Clockwise, fast to slow
				128	Stop
				129 ⇔ 215	Counterclockwise, slow to fast
14	14	12	Auto program delay (ring)	000 ⇔ 255	0–100%
17	17	–	Auto program delay (main)	000 ⇔ 255	0–100%
18	18	13	Background color (ring)	000 ⇔ 255	See Color Chart
19	19	14	Background color dimmer (ring)	000 ⇔ 255	0–100%
–	–	15	Background color dimmer fine (ring)	000 ⇔ 255	0–100%
20	20	–	Background color (main)	000 ⇔ 255	See Color Chart
21	21	–	Background color dimmer (main)	000 ⇔ 255	–100%
22	22	16	Dimmer (ring)	000 ⇔ 255	0–100%
–	23	17	Dimmer fine (ring)	000 ⇔ 255	0–100%
23	24	18	Dimmer (main)	000 ⇔ 255	0–100%
–	25	19	Dimmer fine (main)	000 ⇔ 255	0–100%
24	26	20	Strobe (ring)	000 ⇔ 255	See Strobe Chart
25	27	21	Strobe (main)	000 ⇔ 255	See Strobe Chart
26	28	22	Zoom 1	000 ⇔ 255	Wide to narrow
27	29	23	Zoom 2	000 ⇔ 255	Wide to narrow
28	30	24	Control	000 ⇔ 255	See Control Chart
29	31	–	Red/cyan	000 ⇔ 255	0–100%
–	32	–	Red/cyan fine	000 ⇔ 255	0–100%
30	33	–	Green/magenta	000 ⇔ 255	0–100%

Operation

B	B2	B3	Function	Value	Percent/Setting
-	34	-	Green/magenta fine	000 ⇔ 255	0–100%
31	35	-	Blue/yellow	000 ⇔ 255	0–100%
-	36	-	Blue/yellow fine	000 ⇔ 255	0–100%
32	37	-	White	000 ⇔ 255	0–100%
-	38	-	White fine	000 ⇔ 255	0–100%
-	-	25	Red/cyan (ring)	000 ⇔ 255	0–100%
-	-	26	Red/cyan fine (ring)	000 ⇔ 255	0–100%
-	-	27	Green/magenta (ring)	000 ⇔ 255	0–100%
-	-	28	Green/magenta fine (ring)	000 ⇔ 255	0–100%
-	-	29	Blue/yellow (ring)	000 ⇔ 255	0–100%
-	-	30	Blue/yellow fine (ring)	000 ⇔ 255	0–100%
-	-	31	Red/cyan (main)	000 ⇔ 255	0–100%
-	-	32	Red/cyan fine (main)	000 ⇔ 255	0–100%
-	-	33	Green/magenta (main)	000 ⇔ 255	0–100%
-	-	34	Green/magenta fine (main)	000 ⇔ 255	0–100%
-	-	35	Blue/yellow (main)	000 ⇔ 255	0–100%
-	-	36	Blue/yellow fine (main)	000 ⇔ 255	0–100%
-	-	37	White (main)	000 ⇔ 255	0–100%
-	-	38	White fine (main)	000 ⇔ 255	0–100%

S: Standard (180 channels), A: Advanced (336 channels), T: Tour (416 channels),

S	A	T	Function	Value	Percent/Setting
1	1	1	Pan	000 ⇔ 255	0–100%
2	2	2	Pan fine	000 ⇔ 255	0–100%
3	3	3	Tilt	000 ⇔ 255	0–100%
4	4	4	Tilt fine	000 ⇔ 255	0–100%
5	5	5	Pan/tilt speed	000 ⇔ 255	0–100%
6	6	6	CTC (ring)	000 ⇔ 255	0–100%
7	7	7	CTC (main)	000 ⇔ 255	0–100%
8	8	8	Color macros (ring)	000 ⇔ 255	See Color Chart
9	9	9	Color macros (main)	000 ⇔ 255	See Color Chart
10	10	10	Pattern (ring)	000 ⇔ 004	No function
				005 ⇔ 255	Color macros
11	11	11	Pattern (main)	000	No function
				001 ⇔ 255	Color macros
12	12	12	Auto program (ring)	000 ⇔ 005	No function
				006 ⇔ 215	Auto programs 1-42
				216 ⇔ 255	No function
13	13	13	Auto program speed (ring)	000 ⇔ 127	Clockwise, fast to slow
				128	Stop
				129 ⇔ 215	Counterclockwise, slow to fast
14	14	14	Auto program delay (ring)	000 ⇔ 255	0–100%
15	15	15	Auto program (main)	000 ⇔ 015	No function
				016 ⇔ 255	Auto programs
16	16	16	Auto program speed (main)	000 ⇔ 127	Clockwise, fast to slow
				128	Stop
				129 ⇔ 215	Counterclockwise, slow to fast
17	17	17	Auto program delay (main)	000 ⇔ 255	0–100%
18	18	18	Background color (ring)	000 ⇔ 255	See Color Chart
19	19	19	Background color dimmer (ring)	000 ⇔ 255	0–100%
–	20	20	Background color dimmer fine (ring)	000 ⇔ 255	0–100%
20	21	21	Background color (main)	000 ⇔ 255	See Color Chart
21	22	22	Background color dimmer (main)	000 ⇔ 255	0–100%
–	23	23	Background color dimmer fine (main)	000 ⇔ 255	0–100%
22	24	24	Dimmer (ring)	000 ⇔ 255	0–100%
–	25	25	Dimmer fine (ring)	000 ⇔ 255	0–100%
23	26	26	Dimmer (main)	000 ⇔ 255	0–100%
–	27	27	Dimmer fine (main)	000 ⇔ 255	0–100%
24	28	28	Strobe (ring)	000 ⇔ 255	See Strobe Chart
25	29	29	Strobe (main)	000 ⇔ 255	See Strobe Chart
26	30	30	Zoom 1	000 ⇔ 255	Wide to narrow
27	31	31	Zoom 2	000 ⇔ 255	Wide to narrow
28	32	32	Control	000 ⇔ 255	See Control Chart
29	33	33	Red/cyan (master)	000 ⇔ 255	0–100% default to <000>
–	34	34	Red/cyan fine (master)	000 ⇔ 255	0–100% default to <000>

Operation

S	A	T	Function	Value	Percent/Setting
30	35	35	Green/magenta (master)	000 ⇄ 255	0–100% default to <000>
–	36	36	Green/magenta fine (master)	000 ⇄ 255	0–100% default to <000>
31	37	37	Blue/yellow (master)	000 ⇄ 255	0–100% default to <000>
–	38	38	Blue/yellow fine (master)	000 ⇄ 255	0–100% default to <000>
32	39	39	White (master)	000 ⇄ 255	0–100% default to <000>
–	40	40	White fine (master)	000 ⇄ 255	0–100% default to <000>
–	–	41	Dimmer 1 (ring)	000 ⇄ 255	0–100%
–	–	42	Dimmer 1 fine (ring)	000 ⇄ 255	0–100%
33	41	43	Red/cyan 1 (ring)	000 ⇄ 255	0–100%
–	42	44	Red/cyan 1 fine (ring)	000 ⇄ 255	0–100%
34	43	45	Green/magenta 1 (ring)	000 ⇄ 255	0–100%
–	44	46	Green/magenta 1 fine (ring)	000 ⇄ 255	0–100%
35	45	47	Blue/yellow 1 (ring)	000 ⇄ 255	0–100%
–	46	48	Blue/yellow 1 fine (ring)	000 ⇄ 255	0–100%
–	–	49	Dimmer 2 (ring)	000 ⇄ 255	0–100%
–	–	50	Dimmer 2 fine (ring)	000 ⇄ 255	0–100%
36	47	51	Red/cyan 2 (ring)	000 ⇄ 255	0–100%
–	48	52	Red/cyan 2 fine (ring)	000 ⇄ 255	0–100%
37	49	53	Green/magenta 2 (ring)	000 ⇄ 255	0–100%
–	50	54	Green/magenta 2 fine (ring)	000 ⇄ 255	0–100%
38	51	55	Blue/yellow 2 (ring)	000 ⇄ 255	0–100%
–	52	56	Blue/yellow 2 fine (ring)	000 ⇄ 255	0–100%
–	–	57	Dimmer 3 (ring)	000 ⇄ 255	0–100%
–	–	58	Dimmer 3 fine (ring)	000 ⇄ 255	0–100%
39	53	59	Red/cyan 3 (ring)	000 ⇄ 255	0–100%
–	54	60	Red/cyan 3 fine (ring)	000 ⇄ 255	0–100%
40	55	61	Green/magenta 3 (ring)	000 ⇄ 255	0–100%
–	56	62	Green/magenta 3 fine (ring)	000 ⇄ 255	0–100%
41	57	63	Blue/yellow 3 (ring)	000 ⇄ 255	0–100%
–	58	64	Blue/yellow 3 fine (ring)	000 ⇄ 255	0–100%
–	–	65	Dimmer 4 (ring)	000 ⇄ 255	0–100%
–	–	66	Dimmer 4 fine (ring)	000 ⇄ 255	0–100%
42	59	67	Red/cyan 4 (ring)	000 ⇄ 255	0–100%
–	60	68	Red/cyan 4 fine (ring)	000 ⇄ 255	0–100%
43	61	69	Green/magenta 4 (ring)	000 ⇄ 255	0–100%
–	62	70	Green/magenta 4 fine (ring)	000 ⇄ 255	0–100%
44	63	71	Blue/yellow 4 (ring)	000 ⇄ 255	0–100%
–	64	72	Blue/yellow 4 fine (ring)	000 ⇄ 255	0–100%
–	–	73	Dimmer 5 (ring)	000 ⇄ 255	0–100%
–	–	74	Dimmer 5 fine (ring)	000 ⇄ 255	0–100%
45	65	75	Red/cyan 5 (ring)	000 ⇄ 255	0–100%
–	66	76	Red/cyan 5 fine (ring)	000 ⇄ 255	0–100%
46	67	77	Green/magenta 5 (ring)	000 ⇄ 255	0–100%
–	68	78	Green/magenta 5 fine (ring)	000 ⇄ 255	0–100%
47	69	79	Blue/yellow 5 (ring)	000 ⇄ 255	0–100%
–	70	80	Blue/yellow 5 fine (ring)	000 ⇄ 255	0–100%

S	A	T	Function	Value	Percent/Setting
-	-	81	Dimmer 6 (ring)	000 ⇔ 255	0–100%
-	-	82	Dimmer 6 fine (ring)	000 ⇔ 255	0–100%
48	71	83	Red/cyan 6 (ring)	000 ⇔ 255	0–100%
-	72	84	Red/cyan 6 fine (ring)	000 ⇔ 255	0–100%
49	73	85	Green/magenta 6 (ring)	000 ⇔ 255	0–100%
-	74	86	Green/magenta 6 fine (ring)	000 ⇔ 255	0–100%
50	75	87	Blue/yellow 6 (ring)	000 ⇔ 255	0–100%
-	76	88	Blue/yellow 6 fine (ring)	000 ⇔ 255	0–100%
-	-	89	Dimmer 7 (ring)	000 ⇔ 255	0–100%
-	-	90	Dimmer 7 fine (ring)	000 ⇔ 255	0–100%
51	77	91	Red/cyan 7 (ring)	000 ⇔ 255	0–100%
-	78	92	Red/cyan 7 fine (ring)	000 ⇔ 255	0–100%
52	79	93	Green/magenta 7 (ring)	000 ⇔ 255	0–100%
-	80	94	Green/magenta 7 fine (ring)	000 ⇔ 255	0–100%
53	81	95	Blue/yellow 7 (ring)	000 ⇔ 255	0–100%
-	82	96	Blue/yellow 7 fine (ring)	000 ⇔ 255	0–100%
-	-	97	Dimmer 8 (ring)	000 ⇔ 255	0–100%
-	-	98	Dimmer 8 fine (ring)	000 ⇔ 255	0–100%
54	83	99	Red/cyan 8 (ring)	000 ⇔ 255	0–100%
-	84	100	Red/cyan 8 fine (ring)	000 ⇔ 255	0–100%
55	85	101	Green/magenta 8 (ring)	000 ⇔ 255	0–100%
-	86	102	Green/magenta 8 fine (ring)	000 ⇔ 255	0–100%
56	87	103	Blue/yellow 8 (ring)	000 ⇔ 255	0–100%
-	88	104	Blue/yellow 8 fine (ring)	000 ⇔ 255	0–100%
—	-	105	Dimmer 9 (ring)	000 ⇔ 255	0–100%
-	-	106	Dimmer 9 fine (ring)	000 ⇔ 255	0–100%
57	89	107	Red/cyan 9 (ring)	000 ⇔ 255	0–100%
-	90	108	Red/cyan 9 fine (ring)	000 ⇔ 255	0–100%
58	91	109	Green/magenta 9 (ring)	000 ⇔ 255	0–100%
-	92	110	Green/magenta 9 fine (ring)	000 ⇔ 255	0–100%
59	93	111	Blue/yellow 9 (ring)	000 ⇔ 255	0–100%
-	94	112	Blue/yellow 9 fine (ring)	000 ⇔ 255	0–100%
-	-	113	Dimmer 10 (ring)	000 ⇔ 255	0–100%
-	-	114	Dimmer 10 fine (ring)	000 ⇔ 255	0–100%
60	95	115	Red/cyan 10 (ring)	000 ⇔ 255	0–100%
-	96	116	Red/cyan 10 fine (ring)	000 ⇔ 255	0–100%
61	97	117	Green/magenta 10 (ring)	000 ⇔ 255	0–100%
-	98	118	Green/magenta 10 fine (ring)	000 ⇔ 255	0–100%
62	99	119	Blue/yellow 10 (ring)	000 ⇔ 255	0–100%
-	100	120	Blue/yellow 10 fine (ring)	000 ⇔ 255	0–100%
-	-	121	Dimmer 11 (ring)	000 ⇔ 255	0–100%
-	-	122	Dimmer 11 fine (ring)	000 ⇔ 255	0–100%
63	101	123	Red/cyan 11 (ring)	000 ⇔ 255	0–100%
-	102	124	Red/cyan 11 fine (ring)	000 ⇔ 255	0–100%
64	103	125	Green/magenta 11 (ring)	000 ⇔ 255	0–100%
-	104	126	Green/magenta 11 fine (ring)	000 ⇔ 255	0–100%

Operation

S	A	T	Function	Value	Percent/Setting
65	105	127	Blue/yellow 11 (ring)	000 ⇔ 255	0–100%
–	106	128	Blue/yellow 11 fine (ring)	000 ⇔ 255	0–100%
–	–	129	Dimmer 12 (ring)	000 ⇔ 255	0–100%
–	–	130	Dimmer 12 fine (ring)	000 ⇔ 255	0–100%
66	107	131	Red/cyan 12 (ring)	000 ⇔ 255	0–100%
–	108	132	Red/cyan 12 fine (ring)	000 ⇔ 255	0–100%
67	109	133	Green/magenta 12 (ring)	000 ⇔ 255	0–100%
–	110	134	Green/magenta 12 fine (ring)	000 ⇔ 255	0–100%
68	111	135	Blue/yellow 12 (ring)	000 ⇔ 255	0–100%
–	112	136	Blue/yellow 12 fine (ring)	000 ⇔ 255	0–100%
–	–	137	Dimmer 1 (main)	000 ⇔ 255	0–100%
–	–	138	Dimmer 1 fine (main)	000 ⇔ 255	0–100%
69	113	139	Red/cyan 1 (main)	000 ⇔ 255	0–100%
–	114	140	Red/cyan 1 fine (main)	000 ⇔ 255	0–100%
70	115	141	Green/magenta 1 (main)	000 ⇔ 255	0–100%
–	116	142	Green/magenta 1 fine (main)	000 ⇔ 255	0–100%
71	117	143	Blue/yellow 1 (main)	000 ⇔ 255	0–100%
–	118	144	Blue/yellow 1 fine (main)	000 ⇔ 255	0–100%
72	119	145	White 1 (main)	000 ⇔ 255	0–100%
–	120	146	White 1 fine (main)	000 ⇔ 255	0–100%
–	–	147	Dimmer 2 (main)	000 ⇔ 255	0–100%
–	–	148	Dimmer 2 fine (main)	000 ⇔ 255	0–100%
73	121	149	Red/cyan 2 (main)	000 ⇔ 255	0–100%
–	122	150	Red/cyan 2 fine (main)	000 ⇔ 255	0–100%
74	123	151	Green/magenta 2 (main)	000 ⇔ 255	0–100%
–	124	152	Green/magenta 2 fine (main)	000 ⇔ 255	0–100%
75	125	153	Blue/yellow 2 (main)	000 ⇔ 255	0–100%
–	126	154	Blue/yellow 2 fine (main)	000 ⇔ 255	0–100%
76	127	155	White 2 (main)	000 ⇔ 255	0–100%
–	128	156	White 2 fine (main)	000 ⇔ 255	0–100%
–	–	157	Dimmer 3 (main)	000 ⇔ 255	0–100%
–	–	158	Dimmer 3 fine (main)	000 ⇔ 255	0–100%
77	129	159	Red/cyan 3 (main)	000 ⇔ 255	0–100%
–	130	160	Red/cyan 3 fine (main)	000 ⇔ 255	0–100%
78	131	161	Green/magenta 3 (main)	000 ⇔ 255	0–100%
–	132	162	Green/magenta 3 fine (main)	000 ⇔ 255	0–100%
79	133	163	Blue/yellow 3 (main)	000 ⇔ 255	0–100%
–	134	164	Blue/yellow 3 fine (main)	000 ⇔ 255	0–100%
80	135	165	White 3 (main)	000 ⇔ 255	0–100%
–	136	166	White 3 fine (main)	000 ⇔ 255	0–100%
–	–	167	Dimmer 4 (main)	000 ⇔ 255	0–100%
–	–	168	Dimmer 4 fine (main)	000 ⇔ 255	0–100%
81	137	169	Red/cyan 4 (main)	000 ⇔ 255	0–100%
–	138	170	Red/cyan 4 fine (main)	000 ⇔ 255	0–100%
82	139	171	Green/magenta 4 (main)	000 ⇔ 255	0–100%
–	140	172	Green/magenta 4 fine (main)	000 ⇔ 255	0–100%

S	A	T	Function	Value	Percent/Setting
83	141	173	Blue/yellow 4 (main)	000 ⇔ 255	0–100%
–	142	174	Blue/yellow 4 fine (main)	000 ⇔ 255	0–100%
84	143	175	White 4 (main)	000 ⇔ 255	0–100%
–	144	176	White 4 fine (main)	000 ⇔ 255	0–100%
–	–	177	Dimmer 5 (main)	000 ⇔ 255	0–100%
–	–	178	Dimmer 5 fine (main)	000 ⇔ 255	0–100%
85	145	179	Red/cyan 5 (main)	000 ⇔ 255	0–100%
–	146	180	Red/cyan 5 fine (main)	000 ⇔ 255	0–100%
86	147	181	Green/magenta 5 (main)	000 ⇔ 255	0–100%
–	148	182	Green/magenta 5 fine (main)	000 ⇔ 255	0–100%
87	149	183	Blue/yellow 5 (main)	000 ⇔ 255	0–100%
–	150	184	Blue/yellow 5 fine (main)	000 ⇔ 255	0–100%
88	151	185	White 5 (main)	000 ⇔ 255	0–100%
–	152	186	White 5 fine (main)	000 ⇔ 255	0–100%
–	–	187	Dimmer 6 (main)	000 ⇔ 255	0–100%
–	–	188	Dimmer 6 fine (main)	000 ⇔ 255	0–100%
89	153	189	Red/cyan 6 (main)	000 ⇔ 255	0–100%
–	154	190	Red/cyan 6 fine (main)	000 ⇔ 255	0–100%
90	155	191	Green/magenta 6 (main)	000 ⇔ 255	0–100%
–	156	192	Green/magenta 6 fine (main)	000 ⇔ 255	0–100%
91	157	193	Blue/yellow 6 (main)	000 ⇔ 255	0–100%
–	158	194	Blue/yellow 6 fine (main)	000 ⇔ 255	0–100%
92	159	195	White 6 (main)	000 ⇔ 255	0–100%
–	160	196	White 6 fine (main)	000 ⇔ 255	0–100%
–	–	197	Dimmer 7 (main)	000 ⇔ 255	0–100%
–	–	198	Dimmer 7 fine (main)	000 ⇔ 255	0–100%
93	161	199	Red/cyan 7 (main)	000 ⇔ 255	0–100%
–	162	200	Red/cyan 7 fine (main)	000 ⇔ 255	0–100%
94	163	201	Green/magenta 7 (main)	000 ⇔ 255	0–100%
–	164	202	Green/magenta 7 fine (main)	000 ⇔ 255	0–100%
95	165	203	Blue/yellow 7 (main)	000 ⇔ 255	0–100%
–	166	204	Blue/yellow 7 fine (main)	000 ⇔ 255	0–100%
96	167	205	White 7 (main)	000 ⇔ 255	0–100%
–	168	206	White 7 fine (main)	000 ⇔ 255	0–100%
–	–	207	Dimmer 8 (main)	000 ⇔ 255	0–100%
–	–	208	Dimmer 8 fine (main)	000 ⇔ 255	0–100%
97	169	209	Red/cyan 8 (main)	000 ⇔ 255	0–100%
–	170	210	Red/cyan 8 fine (main)	000 ⇔ 255	0–100%
98	171	211	Green/magenta 8 (main)	000 ⇔ 255	0–100%
–	172	212	Green/magenta 8 fine (main)	000 ⇔ 255	0–100%
99	173	213	Blue/yellow 8 (main)	000 ⇔ 255	0–100%
–	174	214	Blue/yellow 8 fine (main)	000 ⇔ 255	0–100%
100	175	215	White 8 (main)	000 ⇔ 255	0–100%
–	176	216	White 8 fine (main)	000 ⇔ 255	0–100%
–	–	217	Dimmer 9 (main)	000 ⇔ 255	0–100%
–	–	218	Dimmer 9 fine (main)	000 ⇔ 255	0–100%

Operation

S	A	T	Function	Value	Percent/Setting
101	177	219	Red/cyan 9 (main)	000 ⇔ 255	0–100%
–	178	220	Red/cyan 9 fine (main)	000 ⇔ 255	0–100%
102	179	221	Green/magenta 9 (main)	000 ⇔ 255	0–100%
–	180	222	Green/magenta 9 fine (main)	000 ⇔ 255	0–100%
103	181	223	Blue/yellow 9 (main)	000 ⇔ 255	0–100%
–	182	224	Blue/yellow 9 fine (main)	000 ⇔ 255	0–100%
104	183	225	White 9 (main)	000 ⇔ 255	0–100%
–	184	226	White 9 fine (main)	000 ⇔ 255	0–100%
–	–	227	Dimmer 10 (main)	000 ⇔ 255	0–100%
–	–	228	Dimmer 10 fine (main)	000 ⇔ 255	0–100%
105	185	229	Red/cyan 10 (main)	000 ⇔ 255	0–100%
–	186	230	Red/cyan 10 fine (main)	000 ⇔ 255	0–100%
106	187	231	Green/magenta 10 (main)	000 ⇔ 255	0–100%
–	188	232	Green/magenta 10 fine (main)	000 ⇔ 255	0–100%
107	189	233	Blue/yellow 10 (main)	000 ⇔ 255	0–100%
–	190	234	Blue/yellow 10 fine (main)	000 ⇔ 255	0–100%
108	191	235	White 10 (main)	000 ⇔ 255	0–100%
–	192	236	White 10 fine (main)	000 ⇔ 255	0–100%
–	–	237	Dimmer 11 (main)	000 ⇔ 255	0–100%
–	–	238	Dimmer 11 fine (main)	000 ⇔ 255	0–100%
109	193	239	Red/cyan 11 (main)	000 ⇔ 255	0–100%
–	194	240	Red/cyan 11 fine (main)	000 ⇔ 255	0–100%
110	195	241	Green/magenta 11 (main)	000 ⇔ 255	0–100%
–	196	242	Green/magenta 11 fine (main)	000 ⇔ 255	0–100%
111	197	243	Blue/yellow 11 (main)	000 ⇔ 255	0–100%
–	198	244	Blue/yellow 11 fine (main)	000 ⇔ 255	0–100%
112	199	245	White 11 (main)	000 ⇔ 255	0–100%
–	200	246	White 11 fine (main)	000 ⇔ 255	0–100%
–	–	247	Dimmer 12 (main)	000 ⇔ 255	0–100%
–	–	248	Dimmer 12 fine (main)	000 ⇔ 255	0–100%
113	201	249	Red/cyan 12 (main)	000 ⇔ 255	0–100%
–	202	250	Red/cyan 12 fine (main)	000 ⇔ 255	0–100%
114	203	251	Green/magenta 12 (main)	000 ⇔ 255	0–100%
–	204	252	Green/magenta 12 fine (main)	000 ⇔ 255	0–100%
115	205	253	Blue/yellow 12 (main)	000 ⇔ 255	0–100%
–	206	254	Blue/yellow 12 fine (main)	000 ⇔ 255	0–100%
116	207	255	White 12 (main)	000 ⇔ 255	0–100%
–	208	256	White 12 fine (main)	000 ⇔ 255	0–100%
–	–	257	Dimmer 13 (main)	000 ⇔ 255	0–100%
–	–	258	Dimmer 13 fine (main)	000 ⇔ 255	0–100%
117	209	259	Red/cyan 13 (main)	000 ⇔ 255	0–100%
–	210	260	Red/cyan 13 fine (main)	000 ⇔ 255	0–100%
118	211	261	Green/magenta 13 (main)	000 ⇔ 255	0–100%
–	212	262	Green/magenta 13 fine (main)	000 ⇔ 255	0–100%
119	213	263	Blue/yellow 13 (main)	000 ⇔ 255	0–100%
–	214	264	Blue/yellow 13 fine (main)	000 ⇔ 255	0–100%

S	A	T	Function	Value	Percent/Setting
120	215	265	White 13 (main)	000 ⇔ 255	0–100%
–	216	266	White 13 fine (main)	000 ⇔ 255	0–100%
–	–	267	Dimmer 14 (main)	000 ⇔ 255	0–100%
–	–	268	Dimmer 14 fine (main)	000 ⇔ 255	0–100%
121	217	269	Red/cyan 14 (main)	000 ⇔ 255	0–100%
–	218	270	Red/cyan 14 fine (main)	000 ⇔ 255	0–100%
122	219	271	Green/magenta 14 (main)	000 ⇔ 255	0–100%
–	220	272	Green/magenta 14 fine (main)	000 ⇔ 255	0–100%
123	221	273	Blue/yellow 14 (main)	000 ⇔ 255	0–100%
–	222	274	Blue/yellow 14 fine (main)	000 ⇔ 255	0–100%
124	223	275	White 14 (main)	000 ⇔ 255	0–100%
–	224	276	White 14 fine (main)	000 ⇔ 255	0–100%
–	–	277	Dimmer 15 (main)	000 ⇔ 255	0–100%
–	–	278	Dimmer 15 fine (main)	000 ⇔ 255	0–100%
125	225	279	Red/cyan 15 (main)	000 ⇔ 255	0–100%
–	226	280	Red/cyan 15 fine (main)	000 ⇔ 255	0–100%
126	227	281	Green/magenta 15 (main)	000 ⇔ 255	0–100%
–	228	282	Green/magenta 15 fine (main)	000 ⇔ 255	0–100%
127	229	283	Blue/yellow 15 (main)	000 ⇔ 255	0–100%
–	230	284	Blue/yellow 15 fine (main)	000 ⇔ 255	0–100%
128	231	285	White 15 (main)	000 ⇔ 255	0–100%
–	232	286	White 15 fine (main)	000 ⇔ 255	0–100%
–	–	287	Dimmer 16 (main)	000 ⇔ 255	0–100%
–	–	288	Dimmer 16 fine (main)	000 ⇔ 255	0–100%
129	233	289	Red/cyan 16 (main)	000 ⇔ 255	0–100%
–	234	290	Red/cyan 16 fine (main)	000 ⇔ 255	0–100%
130	235	291	Green/magenta 16 (main)	000 ⇔ 255	0–100%
–	236	292	Green/magenta 16 fine (main)	000 ⇔ 255	0–100%
131	237	293	Blue/yellow 16 (main)	000 ⇔ 255	0–100%
–	238	294	Blue/yellow 16 fine (main)	000 ⇔ 255	0–100%
132	239	295	White 16 (main)	000 ⇔ 255	0–100%
–	240	296	White 16 fine (main)	000 ⇔ 255	0–100%
–	–	297	Dimmer 17 (main)	000 ⇔ 255	0–100%
–	–	298	Dimmer 17 fine (main)	000 ⇔ 255	0–100%
133	241	299	Red/cyan 17 (main)	000 ⇔ 255	0–100%
–	242	300	Red/cyan 17 fine (main)	000 ⇔ 255	0–100%
134	243	301	Green/magenta 17 (main)	000 ⇔ 255	0–100%
–	244	302	Green/magenta 17 fine (main)	000 ⇔ 255	0–100%
135	245	303	Blue/yellow 17 (main)	000 ⇔ 255	0–100%
–	246	304	Blue/yellow 17 fine (main)	000 ⇔ 255	0–100%
136	247	305	White 17 (main)	000 ⇔ 255	0–100%
–	248	306	White 17 fine (main)	000 ⇔ 255	0–100%
–	–	307	Dimmer 18 (main)	000 ⇔ 255	0–100%
–	–	308	Dimmer 18 fine (main)	000 ⇔ 255	0–100%
137	249	309	Red/cyan 18 (main)	000 ⇔ 255	0–100%
–	250	310	Red/cyan 18 fine (main)	000 ⇔ 255	0–100%

Operation

S	A	T	Function	Value	Percent/Setting
138	251	311	Green/magenta 18 (main)	000 ⇔ 255	0–100%
–	252	312	Green/magenta 18 fine (main)	000 ⇔ 255	0–100%
139	253	313	Blue/yellow 18 (main)	000 ⇔ 255	0–100%
–	254	314	Blue/yellow 18 fine (main)	000 ⇔ 255	0–100%
140	255	315	White 18 (main)	000 ⇔ 255	0–100%
–	256	316	White 18 fine (main)	000 ⇔ 255	0–100%
–	–	317	Dimmer 19 (main)	000 ⇔ 255	0–100%
–	–	318	Dimmer 19 fine (main)	000 ⇔ 255	0–100%
141	257	319	Red/cyan 19 (main)	000 ⇔ 255	0–100%
–	258	320	Red/cyan 19 fine (main)	000 ⇔ 255	0–100%
142	259	321	Green/magenta 19 (main)	000 ⇔ 255	0–100%
–	260	322	Green/magenta 19 fine (main)	000 ⇔ 255	0–100%
143	261	323	Blue/yellow 19 (main)	000 ⇔ 255	0–100%
–	262	324	Blue/yellow 19 fine (main)	000 ⇔ 255	0–100%
144	263	325	White 19 (main)	000 ⇔ 255	0–100%
–	264	326	White 19 fine (main)	000 ⇔ 255	0–100%
–	–	327	Dimmer 20(main)	000 ⇔ 255	0–100%
–	–	328	Dimmer 20 fine (main)	000 ⇔ 255	0–100%
145	265	329	Red/cyan 20 (main)	000 ⇔ 255	0–100%
–	266	330	Red/cyan 20 fine (main)	000 ⇔ 255	0–100%
146	267	331	Green/magenta 20 (main)	000 ⇔ 255	0–100%
–	268	332	Green/magenta 20 fine (main)	000 ⇔ 255	0–100%
147	269	333	Blue/yellow 20 (main)	000 ⇔ 255	0–100%
–	270	334	Blue/yellow 20 fine (main)	000 ⇔ 255	0–100%
148	271	335	White 20 (main)	000 ⇔ 255	0–100%
–	272	336	White 20 fine (main)	000 ⇔ 255	0–100%
–	–	337	Dimmer 21 (main)	000 ⇔ 255	0–100%
–	–	338	Dimmer 21 fine (main)	000 ⇔ 255	0–100%
149	273	339	Red/cyan 21 (main)	000 ⇔ 255	0–100%
–	274	340	Red/cyan 21 fine (main)	000 ⇔ 255	0–100%
150	275	341	Green/magenta 21 (main)	000 ⇔ 255	0–100%
–	276	342	Green/magenta 21 fine (main)	000 ⇔ 255	0–100%
151	277	343	Blue/yellow 21 (main)	000 ⇔ 255	0–100%
–	278	344	Blue/yellow 21 fine (main)	000 ⇔ 255	0–100%
152	279	345	White 21 (main)	000 ⇔ 255	0–100%
–	280	346	White 21 fine (main)	000 ⇔ 255	0–100%
–	–	347	Dimmer 22 (main)	000 ⇔ 255	0–100%
–	–	348	Dimmer 22 fine (main)	000 ⇔ 255	0–100%
153	281	349	Red/cyan 22 (main)	000 ⇔ 255	0–100%
–	282	350	Red/cyan 22 fine (main)	000 ⇔ 255	0–100%
154	283	351	Green/magenta 22 (main)	000 ⇔ 255	0–100%
–	284	352	Green/magenta 22 fine (main)	000 ⇔ 255	0–100%
155	285	353	Blue/yellow 22 (main)	000 ⇔ 255	0–100%
–	286	354	Blue/yellow 22 fine (main)	000 ⇔ 255	0–100%
156	287	355	White 22 (main)	000 ⇔ 255	0–100%
–	288	356	White 22 fine (main)	000 ⇔ 255	0–100%

S	A	T	Function	Value	Percent/Setting
-	-	357	Dimmer 23 (main)	000 ⇔ 255	0–100%
-	-	358	Dimmer 23 fine (main)	000 ⇔ 255	0–100%
157	289	359	Red/cyan 23 (main)	000 ⇔ 255	0–100%
-	290	360	Red/cyan 23 fine (main)	000 ⇔ 255	0–100%
158	291	361	Green/magenta 23 (main)	000 ⇔ 255	0–100%
-	292	362	Green/magenta 23 fine (main)	000 ⇔ 255	0–100%
159	293	363	Blue/yellow 23 (main)	000 ⇔ 255	0–100%
-	294	364	Blue/yellow 23 fine (main)	000 ⇔ 255	0–100%
160	295	365	White 23 (main)	000 ⇔ 255	0–100%
-	296	366	White 23 fine (main)	000 ⇔ 255	0–100%
-	-	337	Dimmer 24 (main)	000 ⇔ 255	0–100%
-	-	368	Dimmer 24 fine (main)	000 ⇔ 255	0–100%
161	297	369	Red/cyan 24 (main)	000 ⇔ 255	0–100%
-	298	370	Red/cyan 24 fine (main)	000 ⇔ 255	0–100%
162	299	371	Green/magenta 24 (main)	000 ⇔ 255	0–100%
-	300	372	Green/magenta 24 fine (main)	000 ⇔ 255	0–100%
163	301	373	Blue/yellow 24 (main)	000 ⇔ 255	0–100%
-	302	374	Blue/yellow 24 fine (main)	000 ⇔ 255	0–100%
164	303	375	White 24 (main)	000 ⇔ 255	0–100%
-	304	376	White 24 fine (main)	000 ⇔ 255	0–100%
-	-	377	Dimmer 25 (main)	000 ⇔ 255	0–100%
-	-	378	Dimmer 25 fine (main)	000 ⇔ 255	0–100%
165	305	379	Red/cyan 25 (main)	000 ⇔ 255	0–100%
-	306	380	Red/cyan 25 fine (main)	000 ⇔ 255	0–100%
166	307	381	Green/magenta 25 (main)	000 ⇔ 255	0–100%
-	308	382	Green/magenta 25 fine (main)	000 ⇔ 255	0–100%
167	309	383	Blue/yellow 25 (main)	000 ⇔ 255	0–100%
-	310	384	Blue/yellow 25 fine (main)	000 ⇔ 255	0–100%
168	311	385	White 25 (main)	000 ⇔ 255	0–100%
-	312	386	White 25 fine (main)	000 ⇔ 255	0–100%
-	-	387	Dimmer 26 (main)	000 ⇔ 255	0–100%
-	-	388	Dimmer 26 fine (main)	000 ⇔ 255	0–100%
169	313	389	Red/cyan 26 (main)	000 ⇔ 255	0–100%
-	314	390	Red/cyan 26 fine (main)	000 ⇔ 255	0–100%
170	315	391	Green/magenta 26 (main)	000 ⇔ 255	0–100%
-	316	392	Green/magenta 26 fine (main)	000 ⇔ 255	0–100%
171	317	393	Blue/yellow 26 (main)	000 ⇔ 255	0–100%
-	318	394	Blue/yellow 26 fine (main)	000 ⇔ 255	0–100%
172	319	395	White 26 (main)	000 ⇔ 255	0–100%
-	320	396	White 26 fine (main)	000 ⇔ 255	0–100%
-	-	397	Dimmer 27 (main)	000 ⇔ 255	0–100%
-	-	398	Dimmer 27 fine (main)	000 ⇔ 255	0–100%
173	321	399	Red/cyan 27 (main)	000 ⇔ 255	0–100%
-	322	400	Red/cyan 27 fine (main)	000 ⇔ 255	0–100%
174	323	401	Green/magenta 27 (main)	000 ⇔ 255	0–100%
-	324	402	Green/magenta 27 fine (main)	000 ⇔ 255	0–100%

Operation

S	A	T	Function	Value	Percent/Setting
175	325	403	Blue/yellow 27 (main)	000 ⇔ 255	0–100%
–	326	404	Blue/yellow 27 fine (main)	000 ⇔ 255	0–100%
176	327	405	White 27 (main)	000 ⇔ 255	0–100%
–	328	406	White 27 fine (main)	000 ⇔ 255	0–100%
–	–	407	Dimmer 28 (main)	000 ⇔ 255	0–100%
–	–	408	Dimmer 28 fine (main)	000 ⇔ 255	0–100%
177	329	409	Red/cyan 28 (main)	000 ⇔ 255	0–100%
–	330	410	Red/cyan 28 fine (main)	000 ⇔ 255	0–100%
178	331	411	Green/magenta 28 (main)	000 ⇔ 255	0–100%
–	332	412	Green/magenta 28 fine (main)	000 ⇔ 255	0–100%
179	333	413	Blue/yellow 28 (main)	000 ⇔ 255	0–100%
–	334	414	Blue/yellow 28 fine (main)	000 ⇔ 255	0–100%
180	335	415	White 28 (main)	000 ⇔ 255	0–100%
–	336	416	White 28 fine (main)	000 ⇔ 255	0–100%

PXL: Full Pixel (424 channels)

Channel	Function	Value	Percent/Setting
1	Pan	000 ⇄ 255	0–100%
2	Pan fine	000 ⇄ 255	0–100%
3	Tilt	000 ⇄ 255	0–100%
4	Tilt fine	000 ⇄ 255	0–100%
5	Pan/tilt speed	000 ⇄ 255	0–100%
6	Zoom 1	000 ⇄ 255	Wide to narrow
7	Zoom 2	000 ⇄ 255	Wide to narrow
8	Dimmer 1	000 ⇄ 255	0–100%
9	Dimmer 1 fine	000 ⇄ 255	0–100%
10	Strobe 1	000 ⇄ 255	See Strobe Chart
11	Red/cyan 1 (ring)	000 ⇄ 255	0–100%
12	Red/cyan 1 fine (ring)	000 ⇄ 255	0–100%
13	Green/magenta 1 (ring)	000 ⇄ 255	0–100%
14	Green/magenta 1 fine (ring)	000 ⇄ 255	0–100%
15	Blue/yellow 1 (ring)	000 ⇄ 255	0–100%
16	Blue/yellow 1 fine (ring)	000 ⇄ 255	0–100%
17	Dimmer 2 (ring)	000 ⇄ 255	0–100%
18	Dimmer 2 fine (ring)	000 ⇄ 255	0–100%
19	Strobe 2 (ring)	000 ⇄ 255	See Strobe Chart
20	Red/cyan 2 (ring)	000 ⇄ 255	0–100%
21	Red/cyan 2 fine (ring)	000 ⇄ 255	0–100%
22	Green/magenta 2 (ring)	000 ⇄ 255	0–100%
23	Green/magenta 2 fine (ring)	000 ⇄ 255	0–100%
24	Blue/yellow 2 (ring)	000 ⇄ 255	0–100%
25	Blue/yellow 2 fine (ring)	000 ⇄ 255	0–100%
26	Dimmer 3 (ring)	000 ⇄ 255	0–100%
27	Dimmer 3 fine (ring)	000 ⇄ 255	0–100%
28	Strobe 3 (ring)	000 ⇄ 255	See Strobe Chart
29	Red/cyan 3 (ring)	000 ⇄ 255	0–100%
30	Red/cyan 3 fine (ring)	000 ⇄ 255	0–100%
31	Green/magenta 3 (ring)	000 ⇄ 255	0–100%
32	Green/magenta 3 fine (ring)	000 ⇄ 255	0–100%
33	Blue/yellow 3 (ring)	000 ⇄ 255	0–100%
34	Blue/yellow 3 fine (ring)	000 ⇄ 255	0–100%
35	Dimmer 4 (ring)	000 ⇄ 255	0–100%
36	Dimmer 4 fine (ring)	000 ⇄ 255	0–100%
37	Strobe 4 (ring)	000 ⇄ 255	See Strobe Chart
38	Red/cyan 4 (ring)	000 ⇄ 255	0–100%
39	Red/cyan 4 fine (ring)	000 ⇄ 255	0–100%
40	Green/magenta 4 (ring)	000 ⇄ 255	0–100%
41	Green/magenta 4 fine (ring)	000 ⇄ 255	0–100%
42	Blue/yellow 4 (ring)	000 ⇄ 255	0–100%
43	Blue/yellow 4 fine (ring)	000 ⇄ 255	0–100%
44	Dimmer 5 (ring)	000 ⇄ 255	0–100%
45	Dimmer 5 fine (ring)	000 ⇄ 255	0–100%

Operation

Channel	Function	Value	Percent/Setting
46	Strobe 5 (ring)	000 ⇔ 255	See Strobe Chart
47	Red/cyan 5 (ring)	000 ⇔ 255	0–100%
48	Red/cyan 5 fine (ring)	000 ⇔ 255	0–100%
49	Green/magenta 5 (ring)	000 ⇔ 255	0–100%
50	Green/magenta 5 fine (ring)	000 ⇔ 255	0–100%
51	Blue/yellow 5 (ring)	000 ⇔ 255	0–100%
52	Blue/yellow 5 fine (ring)	000 ⇔ 255	0–100%
53	Dimmer 6 (ring)	000 ⇔ 255	0–100%
54	Dimmer 6 fine (ring)	000 ⇔ 255	0–100%
55	Strobe 6 (ring)	000 ⇔ 255	See Strobe Chart
56	Red/cyan 6 (ring)	000 ⇔ 255	0–100%
57	Red/cyan 6 fine (ring)	000 ⇔ 255	0–100%
58	Green/magenta 6 (ring)	000 ⇔ 255	0–100%
59	Green/magenta 6 fine (ring)	000 ⇔ 255	0–100%
60	Blue/yellow 6 (ring)	000 ⇔ 255	0–100%
61	Blue/yellow 6 fine (ring)	000 ⇔ 255	0–100%
62	Dimmer 7 (ring)	000 ⇔ 255	0–100%
63	Dimmer 7 fine (ring)	000 ⇔ 255	0–100%
64	Strobe 7 (ring)	000 ⇔ 255	See Strobe Chart
65	Red/cyan 7 (ring)	000 ⇔ 255	0–100%
66	Red/cyan 7 fine (ring)	000 ⇔ 255	0–100%
67	Green/magenta 7 (ring)	000 ⇔ 255	0–100%
68	Green/magenta 7 fine (ring)	000 ⇔ 255	0–100%
69	Blue/yellow 7 (ring)	000 ⇔ 255	0–100%
70	Blue/yellow 7 fine (ring)	000 ⇔ 255	0–100%
71	Dimmer 8 (ring)	000 ⇔ 255	0–100%
72	Dimmer 8 fine (ring)	000 ⇔ 255	0–100%
73	Strobe 8 (ring)	000 ⇔ 255	See Strobe Chart
74	Red/cyan 8 (ring)	000 ⇔ 255	0–100%
75	Red/cyan 8 fine (ring)	000 ⇔ 255	0–100%
76	Green/magenta 8 (ring)	000 ⇔ 255	0–100%
77	Green/magenta 8 fine (ring)	000 ⇔ 255	0–100%
78	Blue/yellow 8 (ring)	000 ⇔ 255	0–100%
79	Blue/yellow 8 fine (ring)	000 ⇔ 255	0–100%
80	Dimmer 9 (ring)	000 ⇔ 255	0–100%
81	Dimmer 9 fine (ring)	000 ⇔ 255	0–100%
82	Strobe 9 (ring)	000 ⇔ 255	See Strobe Chart
83	Red/cyan 9 (ring)	000 ⇔ 255	0–100%
84	Red/cyan 9 fine (ring)	000 ⇔ 255	0–100%
85	Green/magenta 9 (ring)	000 ⇔ 255	0–100%
86	Green/magenta 9 fine (ring)	000 ⇔ 255	0–100%
87	Blue/yellow 9 (ring)	000 ⇔ 255	0–100%
88	Blue/yellow 9 fine (ring)	000 ⇔ 255	0–100%
89	Dimmer 10 (ring)	000 ⇔ 255	0–100%
90	Dimmer 10 fine (ring)	000 ⇔ 255	0–100%
91	Strobe 10 (ring)	000 ⇔ 255	See Strobe Chart

Channel	Function	Value	Percent/Setting
92	Red/cyan 10 (ring)	000 ⇔ 255	0–100%
93	Red/cyan 10 fine (ring)	000 ⇔ 255	0–100%
94	Green/magenta 10 (ring)	000 ⇔ 255	0–100%
95	Green/magenta 10 fine (ring)	000 ⇔ 255	0–100%
96	Blue/yellow 10 (ring)	000 ⇔ 255	0–100%
97	Blue/yellow 10 fine (ring)	000 ⇔ 255	0–100%
98	Dimmer 11 (ring)	000 ⇔ 255	0–100%
99	Dimmer 11 fine (ring)	000 ⇔ 255	0–100%
100	Strobe 11 (ring)	000 ⇔ 255	See Strobe Chart
101	Red/cyan 11 (ring)	000 ⇔ 255	0–100%
102	Red/cyan 11 fine (ring)	000 ⇔ 255	0–100%
103	Green/magenta 11 (ring)	000 ⇔ 255	0–100%
104	Green/magenta 11 fine (ring)	000 ⇔ 255	0–100%
105	Blue/yellow 11 (ring)	000 ⇔ 255	0–100%
106	Blue/yellow 11 fine (ring)	000 ⇔ 255	0–100%
107	Dimmer 12 (ring)	000 ⇔ 255	0–100%
108	Dimmer 12 fine (ring)	000 ⇔ 255	0–100%
109	Strobe 12 (ring)	000 ⇔ 255	See Strobe Chart
110	Red/cyan 12 (ring)	000 ⇔ 255	0–100%
111	Red/cyan 12 fine (ring)	000 ⇔ 255	0–100%
112	Green/magenta 12 (ring)	000 ⇔ 255	0–100%
113	Green/magenta 12 fine (ring)	000 ⇔ 255	0–100%
114	Blue/yellow 12 (ring)	000 ⇔ 255	0–100%
115	Blue/yellow 12 fine (ring)	000 ⇔ 255	0–100%
116	Dimmer 1 (main)	000 ⇔ 255	0–100%
117	Dimmer 1 fine (main)	000 ⇔ 255	0–100%
118	Strobe 1 (main)	000 ⇔ 255	See Strobe Chart
119	Red/cyan 1 (main)	000 ⇔ 255	0–100%
120	Red/cyan 1 fine (main)	000 ⇔ 255	0–100%
121	Green/magenta 1 (main)	000 ⇔ 255	0–100%
122	Green/magenta 1 fine (main)	000 ⇔ 255	0–100%
123	Blue/yellow 1 (main)	000 ⇔ 255	0–100%
124	Blue/yellow 1 fine (main)	000 ⇔ 255	0–100%
125	White 1 (main)	000 ⇔ 255	0–100%
126	White 1 fine (main)	000 ⇔ 255	0–100%
127	Dimmer 2 (main)	000 ⇔ 255	0–100%
128	Dimmer 2 fine (main)	000 ⇔ 255	0–100%
129	Strobe 2 (main)	000 ⇔ 255	See Strobe Chart
130	Red/cyan 2 (main)	000 ⇔ 255	0–100%
131	Red/cyan 2 fine (main)	000 ⇔ 255	0–100%
132	Green/magenta 2 (main)	000 ⇔ 255	0–100%
133	Green/magenta 2 fine (main)	000 ⇔ 255	0–100%
134	Blue/yellow 2 (main)	000 ⇔ 255	0–100%
135	Blue/yellow 2 fine (main)	000 ⇔ 255	0–100%
136	White 2 (main)	000 ⇔ 255	0–100%
137	White 2 fine (main)	000 ⇔ 255	0–100%

Operation

Channel	Function	Value	Percent/Setting
138	Dimmer 3 (main)	000 ⇔ 255	0–100%
139	Dimmer 3 fine (main)	000 ⇔ 255	0–100%
140	Strobe 3 (main)	000 ⇔ 255	See Strobe Chart
141	Red/cyan 3 (main)	000 ⇔ 255	0–100%
142	Red/cyan 3 fine (main)	000 ⇔ 255	0–100%
143	Green/magenta 3 (main)	000 ⇔ 255	0–100%
144	Green/magenta 3 fine (main)	000 ⇔ 255	0–100%
145	Blue/yellow 3 (main)	000 ⇔ 255	0–100%
146	Blue/yellow 3 fine (main)	000 ⇔ 255	0–100%
147	White 3 (main)	000 ⇔ 255	0–100%
148	White 3 fine (main)	000 ⇔ 255	0–100%
149	Dimmer 4 (main)	000 ⇔ 255	0–100%
150	Dimmer 4 fine (main)	000 ⇔ 255	0–100%
151	Strobe 4 (main)	000 ⇔ 255	See Strobe Chart
152	Red/cyan 4 (main)	000 ⇔ 255	0–100%
153	Red/cyan 4 fine (main)	000 ⇔ 255	0–100%
154	Green/magenta 4 (main)	000 ⇔ 255	0–100%
155	Green/magenta 4 fine (main)	000 ⇔ 255	0–100%
156	Blue/yellow 4 (main)	000 ⇔ 255	0–100%
157	Blue/yellow 4 fine (main)	000 ⇔ 255	0–100%
158	White 4 (main)	000 ⇔ 255	0–100%
159	White 4 fine (main)	000 ⇔ 255	0–100%
160	Dimmer 5 (main)	000 ⇔ 255	0–100%
161	Dimmer 5 fine (main)	000 ⇔ 255	0–100%
162	Strobe 5 (main)	000 ⇔ 255	See Strobe Chart
163	Red/cyan 5 (main)	000 ⇔ 255	0–100%
164	Red/cyan 5 fine (main)	000 ⇔ 255	0–100%
165	Green/magenta 5 (main)	000 ⇔ 255	0–100%
166	Green/magenta 5 fine (main)	000 ⇔ 255	0–100%
167	Blue/yellow 5 (main)	000 ⇔ 255	0–100%
168	Blue/yellow 5 fine (main)	000 ⇔ 255	0–100%
169	White 5 (main)	000 ⇔ 255	0–100%
170	White 5 fine (main)	000 ⇔ 255	0–100%
171	Dimmer 6 (main)	000 ⇔ 255	0–100%
172	Dimmer 6 fine (main)	000 ⇔ 255	0–100%
173	Strobe 6 (main)	000 ⇔ 255	See Strobe Chart
174	Red/cyan 6 (main)	000 ⇔ 255	0–100%
175	Red/cyan 6 fine (main)	000 ⇔ 255	0–100%
176	Green/magenta 6 (main)	000 ⇔ 255	0–100%
177	Green/magenta 6 fine (main)	000 ⇔ 255	0–100%
178	Blue/yellow 6 (main)	000 ⇔ 255	0–100%
179	Blue/yellow 6 fine (main)	000 ⇔ 255	0–100%
180	White 6 (main)	000 ⇔ 255	0–100%
181	White 6 fine (main)	000 ⇔ 255	0–100%
182	Dimmer 7 (main)	000 ⇔ 255	0–100%
183	Dimmer 7 fine (main)	000 ⇔ 255	0–100%

Channel	Function	Value	Percent/Setting
184	Strobe 7 (main)	000 ⇔ 255	See Strobe Chart
185	Red/cyan 7 (main)	000 ⇔ 255	0–100%
186	Red/cyan 7 fine (main)	000 ⇔ 255	0–100%
187	Green/magenta 7 (main)	000 ⇔ 255	0–100%
188	Green/magenta 7 fine (main)	000 ⇔ 255	0–100%
189	Blue/yellow 7 (main)	000 ⇔ 255	0–100%
190	Blue/yellow 7 fine (main)	000 ⇔ 255	0–100%
191	White 7 (main)	000 ⇔ 255	0–100%
192	White 7 fine (main)	000 ⇔ 255	0–100%
193	Dimmer 8 (main)	000 ⇔ 255	0–100%
194	Dimmer 8 fine (main)	000 ⇔ 255	0–100%
195	Strobe 8 (main)	000 ⇔ 255	See Strobe Chart
196	Red/cyan 8 (main)	000 ⇔ 255	0–100%
197	Red/cyan 8 fine (main)	000 ⇔ 255	0–100%
198	Green/magenta 8 (main)	000 ⇔ 255	0–100%
199	Green/magenta 8 fine (main)	000 ⇔ 255	0–100%
200	Blue/yellow 8 (main)	000 ⇔ 255	0–100%
201	Blue/yellow 8 fine (main)	000 ⇔ 255	0–100%
202	White 8 (main)	000 ⇔ 255	0–100%
203	White 8 fine (main)	000 ⇔ 255	0–100%
204	Dimmer 9 (main)	000 ⇔ 255	0–100%
205	Dimmer 9 fine (main)	000 ⇔ 255	0–100%
206	Strobe 9 (main)	000 ⇔ 255	See Strobe Chart
207	Red/cyan 9 (main)	000 ⇔ 255	0–100%
208	Red/cyan 9 fine (main)	000 ⇔ 255	0–100%
209	Green/magenta 9 (main)	000 ⇔ 255	0–100%
210	Green/magenta 9 fine (main)	000 ⇔ 255	0–100%
211	Blue/yellow 9 (main)	000 ⇔ 255	0–100%
212	Blue/yellow 9 fine (main)	000 ⇔ 255	0–100%
213	White 9 (main)	000 ⇔ 255	0–100%
214	White 9 fine (main)	000 ⇔ 255	0–100%
215	Dimmer 10 (main)	000 ⇔ 255	0–100%
216	Dimmer 10 fine (main)	000 ⇔ 255	0–100%
217	Strobe 10 (main)	000 ⇔ 255	See Strobe Chart
218	Red/cyan 10 (main)	000 ⇔ 255	0–100%
219	Red/cyan 10 fine (main)	000 ⇔ 255	0–100%
220	Green/magenta 10 (main)	000 ⇔ 255	0–100%
221	Green/magenta 10 fine (main)	000 ⇔ 255	0–100%
222	Blue/yellow 10 (main)	000 ⇔ 255	0–100%
223	Blue/yellow 10 fine (main)	000 ⇔ 255	0–100%
224	White 10 (main)	000 ⇔ 255	0–100%
225	White 10 fine (main)	000 ⇔ 255	0–100%
226	Dimmer 11 (main)	000 ⇔ 255	0–100%
227	Dimmer 11 fine (main)	000 ⇔ 255	0–100%
228	Strobe 11 (main)	000 ⇔ 255	See Strobe Chart
229	Red/cyan 11 (main)	000 ⇔ 255	0–100%

Operation

Channel	Function	Value	Percent/Setting
230	Red/cyan 11 fine (main)	000 ⇔ 255	0–100%
231	Green/magenta 11 (main)	000 ⇔ 255	0–100%
232	Green/magenta 11 fine (main)	000 ⇔ 255	0–100%
233	Blue/yellow 11 (main)	000 ⇔ 255	0–100%
234	Blue/yellow 11 fine (main)	000 ⇔ 255	0–100%
235	White 11 (main)	000 ⇔ 255	0–100%
236	White 11 fine (main)	000 ⇔ 255	0–100%
237	Dimmer 12 (main)	000 ⇔ 255	0–100%
238	Dimmer 12 fine (main)	000 ⇔ 255	0–100%
239	Strobe 12 (main)	000 ⇔ 255	See Strobe Chart
240	Red/cyan 12 (main)	000 ⇔ 255	0–100%
241	Red/cyan 12 fine (main)	000 ⇔ 255	0–100%
242	Green/magenta 12 (main)	000 ⇔ 255	0–100%
243	Green/magenta 12 fine (main)	000 ⇔ 255	0–100%
244	Blue/yellow 12 (main)	000 ⇔ 255	0–100%
245	Blue/yellow 12 fine (main)	000 ⇔ 255	0–100%
246	White 12 (main)	000 ⇔ 255	0–100%
247	White 12 fine (main)	000 ⇔ 255	0–100%
248	Dimmer 13 (main)	000 ⇔ 255	0–100%
249	Dimmer 13 fine (main)	000 ⇔ 255	0–100%
250	Strobe 13 (main)	000 ⇔ 255	See Strobe Chart
251	Red/cyan 13 (main)	000 ⇔ 255	0–100%
252	Red/cyan 13 fine (main)	000 ⇔ 255	0–100%
253	Green/magenta 13 (main)	000 ⇔ 255	0–100%
254	Green/magenta 13 fine (main)	000 ⇔ 255	0–100%
255	Blue/yellow 13 (main)	000 ⇔ 255	0–100%
256	Blue/yellow 13 fine (main)	000 ⇔ 255	0–100%
257	White 13 (main)	000 ⇔ 255	0–100%
258	White 13 fine (main)	000 ⇔ 255	0–100%
259	Dimmer 14 (main)	000 ⇔ 255	0–100%
260	Dimmer 14 fine (main)	000 ⇔ 255	0–100%
261	Strobe 14 (main)	000 ⇔ 255	See Strobe Chart
262	Red/cyan 14 (main)	000 ⇔ 255	0–100%
263	Red/cyan 14 fine (main)	000 ⇔ 255	0–100%
264	Green/magenta 14 (main)	000 ⇔ 255	0–100%
265	Green/magenta 14 fine (main)	000 ⇔ 255	0–100%
266	Blue/yellow 14 (main)	000 ⇔ 255	0–100%
267	Blue/yellow 14 fine (main)	000 ⇔ 255	0–100%
268	White 14 (main)	000 ⇔ 255	0–100%
269	White 14 fine (main)	000 ⇔ 255	0–100%
270	Dimmer 15 (main)	000 ⇔ 255	0–100%
271	Dimmer 15 fine (main)	000 ⇔ 255	0–100%
272	Strobe 15 (main)	000 ⇔ 255	See Strobe Chart
273	Red/cyan 15 (main)	000 ⇔ 255	0–100%
274	Red/cyan 15 fine (main)	000 ⇔ 255	0–100%
275	Green/magenta 15 (main)	000 ⇔ 255	0–100%

Channel	Function	Value	Percent/Setting
276	Green/magenta 15 fine (main)	000 ⇔ 255	0–100%
277	Blue/yellow 15 (main)	000 ⇔ 255	0–100%
278	Blue/yellow 15 fine (main)	000 ⇔ 255	0–100%
279	White 15 (main)	000 ⇔ 255	0–100%
280	White 15 fine (main)	000 ⇔ 255	0–100%
281	Dimmer 16 (main)	000 ⇔ 255	0–100%
282	Dimmer 16 fine (main)	000 ⇔ 255	0–100%
283	Strobe 16 (main)	000 ⇔ 255	See Strobe Chart
284	Red/cyan 16 (main)	000 ⇔ 255	0–100%
285	Red/cyan 16 fine (main)	000 ⇔ 255	0–100%
286	Green/magenta 16 (main)	000 ⇔ 255	0–100%
287	Green/magenta 16 fine (main)	000 ⇔ 255	0–100%
288	Blue/yellow 16 (main)	000 ⇔ 255	0–100%
289	Blue/yellow 16 fine (main)	000 ⇔ 255	0–100%
290	White 16 (main)	000 ⇔ 255	0–100%
291	White 16 fine (main)	000 ⇔ 255	0–100%
292	Dimmer 17 (main)	000 ⇔ 255	0–100%
293	Dimmer 17 fine (main)	000 ⇔ 255	0–100%
294	Strobe 17 (main)	000 ⇔ 255	See Strobe Chart
295	Red/cyan 17 (main)	000 ⇔ 255	0–100%
296	Red/cyan 17 fine (main)	000 ⇔ 255	0–100%
297	Green/magenta 17 (main)	000 ⇔ 255	0–100%
298	Green/magenta 17 fine (main)	000 ⇔ 255	0–100%
299	Blue/yellow 17 (main)	000 ⇔ 255	0–100%
300	Blue/yellow 17 fine (main)	000 ⇔ 255	0–100%
301	White 17 (main)	000 ⇔ 255	0–100%
302	White 17 fine (main)	000 ⇔ 255	0–100%
303	Dimmer 18 (main)	000 ⇔ 255	0–100%
304	Dimmer 18 fine (main)	000 ⇔ 255	0–100%
305	Strobe 18 (main)	000 ⇔ 255	See Strobe Chart
306	Red/cyan 18 (main)	000 ⇔ 255	0–100%
307	Red/cyan 18 fine (main)	000 ⇔ 255	0–100%
308	Green/magenta 18 (main)	000 ⇔ 255	0–100%
309	Green/magenta 18 fine (main)	000 ⇔ 255	0–100%
310	Blue/yellow 18 (main)	000 ⇔ 255	0–100%
311	Blue/yellow 18 fine (main)	000 ⇔ 255	0–100%
312	White 18 (main)	000 ⇔ 255	0–100%
313	White 18 fine (main)	000 ⇔ 255	0–100%
314	Dimmer 19 (main)	000 ⇔ 255	0–100%
315	Dimmer 19 fine (main)	000 ⇔ 255	0–100%
316	Strobe 19 (main)	000 ⇔ 255	See Strobe Chart
317	Red/cyan 19 (main)	000 ⇔ 255	0–100%
318	Red/cyan 19 fine (main)	000 ⇔ 255	0–100%
319	Green/magenta 19 (main)	000 ⇔ 255	0–100%
320	Green/magenta 19 fine (main)	000 ⇔ 255	0–100%
321	Blue/yellow 19 (main)	000 ⇔ 255	0–100%

Operation

Channel	Function	Value	Percent/Setting
322	Blue/yellow 19 fine (main)	000 ⇔ 255	0–100%
323	White 19 (main)	000 ⇔ 255	0–100%
324	White 19 fine (main)	000 ⇔ 255	0–100%
325	Dimmer 20(main)	000 ⇔ 255	0–100%
326	Dimmer 20 fine (main)	000 ⇔ 255	0–100%
327	Strobe 20 (main)	000 ⇔ 255	See Strobe Chart
328	Red/cyan 20 (main)	000 ⇔ 255	0–100%
329	Red/cyan 20 fine (main)	000 ⇔ 255	0–100%
330	Green/magenta 20 (main)	000 ⇔ 255	0–100%
331	Green/magenta 20 fine (main)	000 ⇔ 255	0–100%
332	Blue/yellow 20 (main)	000 ⇔ 255	0–100%
333	Blue/yellow 20 fine (main)	000 ⇔ 255	0–100%
334	White 20 (main)	000 ⇔ 255	0–100%
335	White 20 fine (main)	000 ⇔ 255	0–100%
336	Dimmer 21 (main)	000 ⇔ 255	0–100%
337	Dimmer 21 fine (main)	000 ⇔ 255	0–100%
338	Strobe 21 (main)	000 ⇔ 255	See Strobe Chart
339	Red/cyan 21 (main)	000 ⇔ 255	0–100%
340	Red/cyan 21 fine (main)	000 ⇔ 255	0–100%
341	Green/magenta 21 (main)	000 ⇔ 255	0–100%
342	Green/magenta 21 fine (main)	000 ⇔ 255	0–100%
343	Blue/yellow 21 (main)	000 ⇔ 255	0–100%
344	Blue/yellow 21 fine (main)	000 ⇔ 255	0–100%
345	White 21 (main)	000 ⇔ 255	0–100%
346	White 21 fine (main)	000 ⇔ 255	0–100%
347	Dimmer 22 (main)	000 ⇔ 255	0–100%
348	Dimmer 22 fine (main)	000 ⇔ 255	0–100%
349	Strobe 22 (main)	000 ⇔ 255	See Strobe Chart
350	Red/cyan 22 (main)	000 ⇔ 255	0–100%
351	Red/cyan 22 fine (main)	000 ⇔ 255	0–100%
352	Green/magenta 22 (main)	000 ⇔ 255	0–100%
353	Green/magenta 22 fine (main)	000 ⇔ 255	0–100%
354	Blue/yellow 22 (main)	000 ⇔ 255	0–100%
355	Blue/yellow 22 fine (main)	000 ⇔ 255	0–100%
356	White 22 (main)	000 ⇔ 255	0–100%
357	White 22 fine (main)	000 ⇔ 255	0–100%
358	Dimmer 23 (main)	000 ⇔ 255	0–100%
359	Dimmer 23 fine (main)	000 ⇔ 255	0–100%
360	Strobe 23 (main)	000 ⇔ 255	See Strobe Chart
361	Red/cyan 23 (main)	000 ⇔ 255	0–100%
362	Red/cyan 23 fine (main)	000 ⇔ 255	0–100%
363	Green/magenta 23 (main)	000 ⇔ 255	0–100%
364	Green/magenta 23 fine (main)	000 ⇔ 255	0–100%
365	Blue/yellow 23 (main)	000 ⇔ 255	0–100%
366	Blue/yellow 23 fine (main)	000 ⇔ 255	0–100%
367	White 23 (main)	000 ⇔ 255	0–100%

Channel	Function	Value	Percent/Setting
368	White 23 fine (main)	000 ⇔ 255	0–100%
369	Dimmer 24 (main)	000 ⇔ 255	0–100%
370	Dimmer 24 fine (main)	000 ⇔ 255	0–100%
371	Strobe 24 (main)	000 ⇔ 255	See Strobe Chart
372	Red/cyan 24 (main)	000 ⇔ 255	0–100%
373	Red/cyan 24 fine (main)	000 ⇔ 255	0–100%
374	Green/magenta 24 (main)	000 ⇔ 255	0–100%
375	Green/magenta 24 fine (main)	000 ⇔ 255	0–100%
376	Blue/yellow 24 (main)	000 ⇔ 255	0–100%
377	Blue/yellow 24 fine (main)	000 ⇔ 255	0–100%
378	White 24 (main)	000 ⇔ 255	0–100%
379	White 24 fine (main)	000 ⇔ 255	0–100%
380	Dimmer 25 (main)	000 ⇔ 255	0–100%
381	Dimmer 25 fine (main)	000 ⇔ 255	0–100%
382	Strobe 25 (main)	000 ⇔ 255	See Strobe Chart
383	Red/cyan 25 (main)	000 ⇔ 255	0–100%
384	Red/cyan 25 fine (main)	000 ⇔ 255	0–100%
385	Green/magenta 25 (main)	000 ⇔ 255	0–100%
386	Green/magenta 25 fine (main)	000 ⇔ 255	0–100%
387	Blue/yellow 25 (main)	000 ⇔ 255	0–100%
388	Blue/yellow 25 fine (main)	000 ⇔ 255	0–100%
389	White 25 (main)	000 ⇔ 255	0–100%
390	White 25 fine (main)	000 ⇔ 255	0–100%
391	Dimmer 26 (main)	000 ⇔ 255	0–100%
392	Dimmer 26 fine (main)	000 ⇔ 255	0–100%
393	Strobe 26 (main)	000 ⇔ 255	See Strobe Chart
394	Red/cyan 26 (main)	000 ⇔ 255	0–100%
395	Red/cyan 26 fine (main)	000 ⇔ 255	0–100%
396	Green/magenta 26 (main)	000 ⇔ 255	0–100%
397	Green/magenta 26 fine (main)	000 ⇔ 255	0–100%
398	Blue/yellow 26 (main)	000 ⇔ 255	0–100%
399	Blue/yellow 26 fine (main)	000 ⇔ 255	0–100%
400	White 26 (main)	000 ⇔ 255	0–100%
401	White 26 fine (main)	000 ⇔ 255	0–100%
402	Dimmer 27 (main)	000 ⇔ 255	0–100%
403	Dimmer 27 fine (main)	000 ⇔ 255	0–100%
404	Strobe 27 (main)	000 ⇔ 255	See Strobe Chart
405	Red/cyan 27 (main)	000 ⇔ 255	0–100%
406	Red/cyan 27 fine (main)	000 ⇔ 255	0–100%
407	Green/magenta 27 (main)	000 ⇔ 255	0–100%
408	Green/magenta 27 fine (main)	000 ⇔ 255	0–100%
409	Blue/yellow 27 (main)	000 ⇔ 255	0–100%
410	Blue/yellow 27 fine (main)	000 ⇔ 255	0–100%
411	White 27 (main)	000 ⇔ 255	0–100%
412	White 27 fine (main)	000 ⇔ 255	0–100%
413	Dimmer 28 (main)	000 ⇔ 255	0–100%

Operation

Channel	Function	Value	Percent/Setting
414	Dimmer 28 fine (main)	000 ↔ 255	0–100%
415	Strobe 28 (main)	000 ↔ 255	See Strobe Chart
416	Red/cyan 28 (main)	000 ↔ 255	0–100%
417	Red/cyan 28 fine (main)	000 ↔ 255	0–100%
418	Green/magenta 28 (main)	000 ↔ 255	0–100%
419	Green/magenta 28 fine (main)	000 ↔ 255	0–100%
420	Blue/yellow 28 (main)	000 ↔ 255	0–100%
421	Blue/yellow 28 fine (main)	000 ↔ 255	0–100%
422	White 28 (main)	000 ↔ 255	0–100%
423	White 28 fine (main)	000 ↔ 255	0–100%
424	Control	000 ↔ 255	See Control Chart

Dual Control Movement Values

B: Basic (12 channels), S: Standard (35 channels), A: Advanced (46 channels)

B	S	A	Function	Value	Percent/Setting
1	1	1	Pan	000 ⇔ 255	0–100%
2	2	2	Pan fine	000 ⇔ 255	0–100%
3	3	3	Tilt	000 ⇔ 255	0–100%
4	4	4	Tilt fine	000 ⇔ 255	0–100%
5	5	5	Pan/tilt speed	000 ⇔ 255	0–100%
–	6	6	CTC (ring)	000 ⇔ 255	0–100%
–	7	7	CTC (main)	000 ⇔ 255	0–100%
–	8	8	Color macros (ring)	000 ⇔ 255	See Color Chart
–	9	9	Color macros (main)	000 ⇔ 255	See Color Chart
–	10	10	Pattern (ring)	000 ⇔ 004 005 ⇔ 255	No function Color macros
–	11	11	Pattern (main)	000 001 ⇔ 255	No function Color macros
–	12	12	Auto program (ring)	000 ⇔ 005 006 ⇔ 215 216 ⇔ 255	No function Auto programs 1-42 No function
–	13	13	Auto program speed (ring)	000 ⇔ 127 128 129 ⇔ 215	Clockwise, fast to slow Stop Counterclockwise, slow to fast
–	14	14	Auto program delay (ring)	000 ⇔ 255	0–100%
–	15	15	Auto program (main)	000 ⇔ 015 016 ⇔ 255	No function Auto programs
–	16	16	Auto program speed (main)	000 ⇔ 127 128 129 ⇔ 215	Clockwise, fast to slow Stop Counterclockwise, slow to fast
–	17	17	Auto program delay (main)	000 ⇔ 255	0–100%
–	18	18	Background color (ring)	000 ⇔ 255	See Color Chart
–	19	19	Background color dimmer (ring)	000 ⇔ 255	0–100%
–	–	20	Background color dimmer fine (ring)	000 ⇔ 255	0–100%
–	20	21	Background color (main)	000 ⇔ 255	See Color Chart
–	21	22	Background color dimmer (main)	000 ⇔ 255	0–100%
–	–	23	Background color dimmer fine (main)	000 ⇔ 255	0–100%
6	22	24	Dimmer (ring)	000 ⇔ 255	0–100%
–	–	25	Dimmer fine (ring)	000 ⇔ 255	0–100%
7	23	26	Dimmer (main)	000 ⇔ 255	0–100%
–	–	27	Dimmer fine (main)	000 ⇔ 255	0–100%
8	24	28	Strobe (ring)	000 ⇔ 255	See Strobe Chart
9	25	29	Strobe (main)	000 ⇔ 255	See Strobe Chart
10	26	30	Zoom 1	000 ⇔ 255	Wide to narrow
11	27	31	Zoom 2	000 ⇔ 255	Wide to narrow
12	28	32	Control	000 ⇔ 255	See Control Chart

Operation

B	S	A	Function	Value	Percent/Setting
-	29	33	Red/cyan (ring)	000 ⇔ 255	0–100%
-	-	34	Red/cyan fine (ring)	000 ⇔ 255	0–100%
-	30	35	Red/cyan (main)	000 ⇔ 255	0–100%
-	-	36	Red/cyan fine (main)	000 ⇔ 255	0–100%
-	31	37	Green/magenta (ring)	000 ⇔ 255	0–100%
-	-	38	Green/magenta fine (ring)	000 ⇔ 255	0–100%
-	32	39	Green/magenta (main)	000 ⇔ 255	0–100%
-	-	40	Green/magenta fine (main)	000 ⇔ 255	0–100%
-	33	41	Blue/yellow (ring)	000 ⇔ 255	0–100%
-	-	42	Blue/yellow fine (ring)	000 ⇔ 255	0–100%
-	34	43	Blue/yellow (main)	000 ⇔ 255	0–100%
-	-	44	Blue/yellow fine (main)	000 ⇔ 255	0–100%
-	35	45	White (main)	000 ⇔ 255	0–100%
-	-	46	White fine (main)	000 ⇔ 255	0–100%

Dual Control Pixels Values

B: Basic (120 channels), S: Standard (148 channels), A: Advanced (296 channels)

B	S	A	Function	Value	Percent/Setting
1	1	1	Red/cyan 1 (ring)	000 ⇔ 255	0–100%
–	–	2	Red/cyan 1 fine (ring)	000 ⇔ 255	0–100%
2	2	3	Green/magenta 1 (ring)	000 ⇔ 255	0–100%
–	–	4	Green/magenta 1 fine (ring)	000 ⇔ 255	0–100%
3	3	5	Blue/yellow 1 (ring)	000 ⇔ 255	0–100%
–	–	6	Blue/yellow 1 fine (ring)	000 ⇔ 255	0–100%
4	4	7	Red/cyan 2 (ring)	000 ⇔ 255	0–100%
–	–	8	Red/cyan 2 fine (ring)	000 ⇔ 255	0–100%
5	5	9	Green/magenta 2 (ring)	000 ⇔ 255	0–100%
–	–	10	Green/magenta 2 fine (ring)	000 ⇔ 255	0–100%
6	6	11	Blue/yellow 2 (ring)	000 ⇔ 255	0–100%
–	–	12	Blue/yellow 2 fine (ring)	000 ⇔ 255	0–100%
7	7	13	Red/cyan 3 (ring)	000 ⇔ 255	0–100%
–	–	14	Red/cyan 3 fine (ring)	000 ⇔ 255	0–100%
8	8	15	Green/magenta 3 (ring)	000 ⇔ 255	0–100%
–	–	16	Green/magenta 3 fine (ring)	000 ⇔ 255	0–100%
9	9	17	Blue/yellow 3 (ring)	000 ⇔ 255	0–100%
–	–	18	Blue/yellow 3 fine (ring)	000 ⇔ 255	0–100%
10	10	19	Red/cyan 4 (ring)	000 ⇔ 255	0–100%
–	–	20	Red/cyan 4 fine (ring)	000 ⇔ 255	0–100%
11	11	21	Green/magenta 4 (ring)	000 ⇔ 255	0–100%
–	–	22	Green/magenta 4 fine (ring)	000 ⇔ 255	0–100%
12	12	23	Blue/yellow 4 (ring)	000 ⇔ 255	0–100%
–	–	24	Blue/yellow 4 fine (ring)	000 ⇔ 255	0–100%
13	13	25	Red/cyan 5 (ring)	000 ⇔ 255	0–100%
–	–	26	Red/cyan 5 fine (ring)	000 ⇔ 255	0–100%
14	14	27	Green/magenta 5 (ring)	000 ⇔ 255	0–100%
–	–	28	Green/magenta 5 fine (ring)	000 ⇔ 255	0–100%
15	15	29	Blue/yellow 5 (ring)	000 ⇔ 255	0–100%
–	–	30	Blue/yellow 5 fine (ring)	000 ⇔ 255	0–100%
16	16	31	Red/cyan 6 (ring)	000 ⇔ 255	0–100%
–	–	32	Red/cyan 6 fine (ring)	000 ⇔ 255	0–100%
17	17	33	Green/magenta 6 (ring)	000 ⇔ 255	0–100%
–	–	34	Green/magenta 6 fine (ring)	000 ⇔ 255	0–100%
18	18	35	Blue/yellow 6 (ring)	000 ⇔ 255	0–100%
–	–	36	Blue/yellow 6 fine (ring)	000 ⇔ 255	0–100%
19	19	37	Red/cyan 7 (ring)	000 ⇔ 255	0–100%
–	–	38	Red/cyan 7 fine (ring)	000 ⇔ 255	0–100%
20	20	39	Green/magenta 7 (ring)	000 ⇔ 255	0–100%
–	–	40	Green/magenta 7 fine (ring)	000 ⇔ 255	0–100%
21	21	41	Blue/yellow 7 (ring)	000 ⇔ 255	0–100%
–	–	42	Blue/yellow 7 fine (ring)	000 ⇔ 255	0–100%
22	22	43	Red/cyan 8 (ring)	000 ⇔ 255	0–100%
–	–	44	Red/cyan 8 fine (ring)	000 ⇔ 255	0–100%

Operation

B	S	A	Function	Value	Percent/Setting
23	23	45	Green/magenta 8 (ring)	000 ⇔ 255	0–100%
–	–	46	Green/magenta 8 fine (ring)	000 ⇔ 255	0–100%
24	24	47	Blue/yellow 8 (ring)	000 ⇔ 255	0–100%
–	–	48	Blue/yellow 8 fine (ring)	000 ⇔ 255	0–100%
25	25	49	Red/cyan 9 (ring)	000 ⇔ 255	0–100%
–	–	50	Red/cyan 9 fine (ring)	000 ⇔ 255	0–100%
26	26	51	Green/magenta 9 (ring)	000 ⇔ 255	0–100%
–	–	52	Green/magenta 9 fine (ring)	000 ⇔ 255	0–100%
27	27	53	Blue/yellow 9 (ring)	000 ⇔ 255	0–100%
–	–	54	Blue/yellow 9 fine (ring)	000 ⇔ 255	0–100%
28	28	55	Red/cyan 10 (ring)	000 ⇔ 255	0–100%
–	–	56	Red/cyan 10 fine (ring)	000 ⇔ 255	0–100%
29	29	57	Green/magenta 10 (ring)	000 ⇔ 255	0–100%
–	–	58	Green/magenta 10 fine (ring)	000 ⇔ 255	0–100%
30	30	59	Blue/yellow 10 (ring)	000 ⇔ 255	0–100%
–	–	60	Blue/yellow 10 fine (ring)	000 ⇔ 255	0–100%
31	31	61	Red/cyan 11 (ring)	000 ⇔ 255	0–100%
–	–	62	Red/cyan 11 fine (ring)	000 ⇔ 255	0–100%
32	32	63	Green/magenta 11 (ring)	000 ⇔ 255	0–100%
–	–	64	Green/magenta 11 fine (ring)	000 ⇔ 255	0–100%
33	33	65	Blue/yellow 11 (ring)	000 ⇔ 255	0–100%
–	–	66	Blue/yellow 11 fine (ring)	000 ⇔ 255	0–100%
34	34	67	Red/cyan 12 (ring)	000 ⇔ 255	0–100%
–	–	68	Red/cyan 12 fine (ring)	000 ⇔ 255	0–100%
35	35	69	Green/magenta 12 (ring)	000 ⇔ 255	0–100%
–	–	70	Green/magenta 12 fine (ring)	000 ⇔ 255	0–100%
36	36	71	Blue/yellow 12 (ring)	000 ⇔ 255	0–100%
–	–	72	Blue/yellow 12 fine (ring)	000 ⇔ 255	0–100%
37	37	73	Red/cyan 1 (main)	000 ⇔ 255	0–100%
–	–	74	Red/cyan 1 fine (main)	000 ⇔ 255	0–100%
38	38	75	Green/magenta 1 (main)	000 ⇔ 255	0–100%
–	–	76	Green/magenta 1 fine (main)	000 ⇔ 255	0–100%
39	39	77	Blue/yellow 1 (main)	000 ⇔ 255	0–100%
–	–	78	Blue/yellow 1 fine (main)	000 ⇔ 255	0–100%
–	40	79	White 1 (main)	000 ⇔ 255	0–100%
–	–	80	White 1 fine (main)	000 ⇔ 255	0–100%
40	41	81	Red/cyan 2 (main)	000 ⇔ 255	0–100%
–	–	82	Red/cyan 2 fine (main)	000 ⇔ 255	0–100%
41	42	83	Green/magenta 2 (main)	000 ⇔ 255	0–100%
–	–	84	Green/magenta 2 fine (main)	000 ⇔ 255	0–100%
42	43	85	Blue/yellow 2 (main)	000 ⇔ 255	0–100%
–	–	86	Blue/yellow 2 fine (main)	000 ⇔ 255	0–100%
–	44	87	White 2 (main)	000 ⇔ 255	0–100%
–	–	88	White 2 fine (main)	000 ⇔ 255	0–100%
43	45	89	Red/cyan 3 (main)	000 ⇔ 255	0–100%
–	–	90	Red/cyan 3 fine (main)	000 ⇔ 255	0–100%

B	S	A	Function	Value	Percent/Setting
44	46	91	Green/magenta 3 (main)	000 ⇔ 255	0–100%
–	–	92	Green/magenta 3 fine (main)	000 ⇔ 255	0–100%
45	47	93	Blue/yellow 3 (main)	000 ⇔ 255	0–100%
–	–	94	Blue/yellow 3 fine (main)	000 ⇔ 255	0–100%
–	48	95	White 3 (main)	000 ⇔ 255	0–100%
–	–	96	White 3 fine (main)	000 ⇔ 255	0–100%
46	49	97	Red/cyan 4 (main)	000 ⇔ 255	0–100%
–	–	98	Red/cyan 4 fine (main)	000 ⇔ 255	0–100%
47	50	99	Green/magenta 4 (main)	000 ⇔ 255	0–100%
–	–	100	Green/magenta 4 fine (main)	000 ⇔ 255	0–100%
48	51	101	Blue/yellow 4 (main)	000 ⇔ 255	0–100%
–	–	102	Blue/yellow 4 fine (main)	000 ⇔ 255	0–100%
–	52	103	White 4 (main)	000 ⇔ 255	0–100%
–	–	104	White 4 fine (main)	000 ⇔ 255	0–100%
49	53	105	Red/cyan 5 (main)	000 ⇔ 255	0–100%
–	–	106	Red/cyan 5 fine (main)	000 ⇔ 255	0–100%
50	54	107	Green/magenta 5 (main)	000 ⇔ 255	0–100%
–	–	108	Green/magenta 5 fine (main)	000 ⇔ 255	0–100%
51	55	109	Blue/yellow 5 (main)	000 ⇔ 255	0–100%
–	–	110	Blue/yellow 5 fine (main)	000 ⇔ 255	0–100%
–	56	111	White 5 (main)	000 ⇔ 255	0–100%
–	–	112	White 5 fine (main)	000 ⇔ 255	0–100%
52	57	113	Red/cyan 6 (main)	000 ⇔ 255	0–100%
–	–	114	Red/cyan 6 fine (main)	000 ⇔ 255	0–100%
53	58	115	Green/magenta 6 (main)	000 ⇔ 255	0–100%
–	–	116	Green/magenta 6 fine (main)	000 ⇔ 255	0–100%
54	59	117	Blue/yellow 6 (main)	000 ⇔ 255	0–100%
–	–	118	Blue/yellow 6 fine (main)	000 ⇔ 255	0–100%
–	60	119	White 6 (main)	000 ⇔ 255	0–100%
–	–	120	White 6 fine (main)	000 ⇔ 255	0–100%
55	61	121	Red/cyan 7 (main)	000 ⇔ 255	0–100%
–	–	122	Red/cyan 7 fine (main)	000 ⇔ 255	0–100%
56	62	123	Green/magenta 7 (main)	000 ⇔ 255	0–100%
–	–	124	Green/magenta 7 fine (main)	000 ⇔ 255	0–100%
57	63	125	Blue/yellow 7 (main)	000 ⇔ 255	0–100%
–	–	126	Blue/yellow 7 fine (main)	000 ⇔ 255	0–100%
–	64	127	White 7 (main)	000 ⇔ 255	0–100%
–	–	128	White 7 fine (main)	000 ⇔ 255	0–100%
58	65	129	Red/cyan 8 (main)	000 ⇔ 255	0–100%
–	–	130	Red/cyan 8 fine (main)	000 ⇔ 255	0–100%
59	66	131	Green/magenta 8 (main)	000 ⇔ 255	0–100%
–	–	132	Green/magenta 8 fine (main)	000 ⇔ 255	0–100%
60	67	133	Blue/yellow 8 (main)	000 ⇔ 255	0–100%
–	–	134	Blue/yellow 8 fine (main)	000 ⇔ 255	0–100%
–	68	135	White 8 (main)	000 ⇔ 255	0–100%
–	–	136	White 8 fine (main)	000 ⇔ 255	0–100%

Operation

B	S	A	Function	Value	Percent/Setting
61	69	137	Red/cyan 9 (main)	000 ⇔ 255	0–100%
–	–	138	Red/cyan 9 fine (main)	000 ⇔ 255	0–100%
62	70	139	Green/magenta 9 (main)	000 ⇔ 255	0–100%
–	–	140	Green/magenta 9 fine (main)	000 ⇔ 255	0–100%
63	71	141	Blue/yellow 9 (main)	000 ⇔ 255	0–100%
–	–	142	Blue/yellow 9 fine (main)	000 ⇔ 255	0–100%
–	72	143	White 9 (main)	000 ⇔ 255	0–100%
–	–	144	White 9 fine (main)	000 ⇔ 255	0–100%
64	73	145	Red/cyan 10 (main)	000 ⇔ 255	0–100%
–	–	146	Red/cyan 10 fine (main)	000 ⇔ 255	0–100%
65	74	147	Green/magenta 10 (main)	000 ⇔ 255	0–100%
–	–	148	Green/magenta 10 fine (main)	000 ⇔ 255	0–100%
66	75	149	Blue/yellow 10 (main)	000 ⇔ 255	0–100%
–	–	150	Blue/yellow 10 fine (main)	000 ⇔ 255	0–100%
–	76	151	White 10 (main)	000 ⇔ 255	0–100%
–	–	152	White 10 fine (main)	000 ⇔ 255	0–100%
67	77	153	Red/cyan 11 (main)	000 ⇔ 255	0–100%
–	–	154	Red/cyan 11 fine (main)	000 ⇔ 255	0–100%
68	78	155	Green/magenta 11 (main)	000 ⇔ 255	0–100%
–	–	156	Green/magenta 11 fine (main)	000 ⇔ 255	0–100%
69	79	157	Blue/yellow 11 (main)	000 ⇔ 255	0–100%
–	–	158	Blue/yellow 11 fine (main)	000 ⇔ 255	0–100%
–	80	159	White 11 (main)	000 ⇔ 255	0–100%
–	–	160	White 11 fine (main)	000 ⇔ 255	0–100%
70	81	161	Red/cyan 12 (main)	000 ⇔ 255	0–100%
–	–	162	Red/cyan 12 fine (main)	000 ⇔ 255	0–100%
71	82	163	Green/magenta 12 (main)	000 ⇔ 255	0–100%
–	–	164	Green/magenta 12 fine (main)	000 ⇔ 255	0–100%
72	83	165	Blue/yellow 12 (main)	000 ⇔ 255	0–100%
–	–	166	Blue/yellow 12 fine (main)	000 ⇔ 255	0–100%
–	84	167	White 12 (main)	000 ⇔ 255	0–100%
–	–	168	White 12 fine (main)	000 ⇔ 255	0–100%
73	85	169	Red/cyan 13 (main)	000 ⇔ 255	0–100%
–	–	170	Red/cyan 13 fine (main)	000 ⇔ 255	0–100%
74	86	171	Green/magenta 13 (main)	000 ⇔ 255	0–100%
–	–	172	Green/magenta 13 fine (main)	000 ⇔ 255	0–100%
75	87	173	Blue/yellow 13 (main)	000 ⇔ 255	0–100%
–	–	174	Blue/yellow 13 fine (main)	000 ⇔ 255	0–100%
–	88	175	White 13 (main)	000 ⇔ 255	0–100%
–	–	176	White 13 fine (main)	000 ⇔ 255	0–100%
76	89	177	Red/cyan 14 (main)	000 ⇔ 255	0–100%
–	–	178	Red/cyan 14 fine (main)	000 ⇔ 255	0–100%
77	90	179	Green/magenta 14 (main)	000 ⇔ 255	0–100%
–	–	180	Green/magenta 14 fine (main)	000 ⇔ 255	0–100%
78	91	181	Blue/yellow 14 (main)	000 ⇔ 255	0–100%
–	–	182	Blue/yellow 14 fine (main)	000 ⇔ 255	0–100%

B	S	A	Function	Value	Percent/Setting
-	92	183	White 14 (main)	000 ⇔ 255	0–100%
-	-	184	White 14 fine (main)	000 ⇔ 255	0–100%
79	93	185	Red/cyan 15 (main)	000 ⇔ 255	0–100%
-	-	186	Red/cyan 15 fine (main)	000 ⇔ 255	0–100%
80	94	187	Green/magenta 15 (main)	000 ⇔ 255	0–100%
-	-	188	Green/magenta 15 fine (main)	000 ⇔ 255	0–100%
81	95	189	Blue/yellow 15 (main)	000 ⇔ 255	0–100%
-	-	190	Blue/yellow 15 fine (main)	000 ⇔ 255	0–100%
-	96	191	White 15 (main)	000 ⇔ 255	0–100%
-	-	192	White 15 fine (main)	000 ⇔ 255	0–100%
82	97	193	Red/cyan 16 (main)	000 ⇔ 255	0–100%
-	-	194	Red/cyan 16 fine (main)	000 ⇔ 255	0–100%
83	98	195	Green/magenta 16 (main)	000 ⇔ 255	0–100%
-	-	196	Green/magenta 16 fine (main)	000 ⇔ 255	0–100%
84	99	197	Blue/yellow 16 (main)	000 ⇔ 255	0–100%
-	-	198	Blue/yellow 16 fine (main)	000 ⇔ 255	0–100%
-	100	199	White 16 (main)	000 ⇔ 255	0–100%
-	-	200	White 16 fine (main)	000 ⇔ 255	0–100%
85	101	201	Red/cyan 17 (main)	000 ⇔ 255	0–100%
-	-	202	Red/cyan 17 fine (main)	000 ⇔ 255	0–100%
86	102	203	Green/magenta 17 (main)	000 ⇔ 255	0–100%
-	-	204	Green/magenta 17 fine (main)	000 ⇔ 255	0–100%
87	103	205	Blue/yellow 17 (main)	000 ⇔ 255	0–100%
-	-	206	Blue/yellow 17 fine (main)	000 ⇔ 255	0–100%
-	104	207	White 17 (main)	000 ⇔ 255	0–100%
-	-	208	White 17 fine (main)	000 ⇔ 255	0–100%
88	105	209	Red/cyan 18 (main)	000 ⇔ 255	0–100%
-	-	210	Red/cyan 18 fine (main)	000 ⇔ 255	0–100%
89	106	211	Green/magenta 18 (main)	000 ⇔ 255	0–100%
-	-	212	Green/magenta 18 fine (main)	000 ⇔ 255	0–100%
90	107	213	Blue/yellow 18 (main)	000 ⇔ 255	0–100%
-	-	214	Blue/yellow 18 fine (main)	000 ⇔ 255	0–100%
-	108	215	White 18 (main)	000 ⇔ 255	0–100%
-	-	216	White 18 fine (main)	000 ⇔ 255	0–100%
91	109	217	Red/cyan 19 (main)	000 ⇔ 255	0–100%
-	-	218	Red/cyan 19 fine (main)	000 ⇔ 255	0–100%
92	110	219	Green/magenta 19 (main)	000 ⇔ 255	0–100%
-	-	220	Green/magenta 19 fine (main)	000 ⇔ 255	0–100%
93	111	221	Blue/yellow 19 (main)	000 ⇔ 255	0–100%
-	-	222	Blue/yellow 19 fine (main)	000 ⇔ 255	0–100%
-	112	223	White 19 (main)	000 ⇔ 255	0–100%
-	-	224	White 19 fine (main)	000 ⇔ 255	0–100%
94	113	225	Red/cyan 20 (main)	000 ⇔ 255	0–100%
-	-	226	Red/cyan 20 fine (main)	000 ⇔ 255	0–100%
95	114	227	Green/magenta 20 (main)	000 ⇔ 255	0–100%
-	-	228	Green/magenta 20 fine (main)	000 ⇔ 255	0–100%

Operation

B	S	A	Function	Value	Percent/Setting
96	115	229	Blue/yellow 20 (main)	000 ⇔ 255	0–100%
–	–	230	Blue/yellow 20 fine (main)	000 ⇔ 255	0–100%
–	116	231	White 20 (main)	000 ⇔ 255	0–100%
–	–	232	White 20 fine (main)	000 ⇔ 255	0–100%
97	117	233	Red/cyan 21 (main)	000 ⇔ 255	0–100%
–	–	234	Red/cyan 21 fine (main)	000 ⇔ 255	0–100%
98	118	235	Green/magenta 21 (main)	000 ⇔ 255	0–100%
–	–	236	Green/magenta 21 fine (main)	000 ⇔ 255	0–100%
99	119	237	Blue/yellow 21 (main)	000 ⇔ 255	0–100%
–	–	238	Blue/yellow 21 fine (main)	000 ⇔ 255	0–100%
–	120	239	White 21 (main)	000 ⇔ 255	0–100%
–	–	240	White 21 fine (main)	000 ⇔ 255	0–100%
100	121	241	Red/cyan 22 (main)	000 ⇔ 255	0–100%
–	–	242	Red/cyan 22 fine (main)	000 ⇔ 255	0–100%
101	122	243	Green/magenta 22 (main)	000 ⇔ 255	0–100%
–	–	244	Green/magenta 22 fine (main)	000 ⇔ 255	0–100%
102	123	245	Blue/yellow 22 (main)	000 ⇔ 255	0–100%
–	–	246	Blue/yellow 22 fine (main)	000 ⇔ 255	0–100%
–	124	247	White 22 (main)	000 ⇔ 255	0–100%
–	–	248	White 22 fine (main)	000 ⇔ 255	0–100%
103	125	249	Red/cyan 23 (main)	000 ⇔ 255	0–100%
–	–	250	Red/cyan 23 fine (main)	000 ⇔ 255	0–100%
104	126	251	Green/magenta 23 (main)	000 ⇔ 255	0–100%
–	–	252	Green/magenta 23 fine (main)	000 ⇔ 255	0–100%
105	127	253	Blue/yellow 23 (main)	000 ⇔ 255	0–100%
–	–	254	Blue/yellow 23 fine (main)	000 ⇔ 255	0–100%
–	128	255	White 23 (main)	000 ⇔ 255	0–100%
–	–	256	White 23 fine (main)	000 ⇔ 255	0–100%
106	129	257	Red/cyan 24 (main)	000 ⇔ 255	0–100%
–	–	258	Red/cyan 24 fine (main)	000 ⇔ 255	0–100%
107	130	259	Green/magenta 24 (main)	000 ⇔ 255	0–100%
–	–	260	Green/magenta 24 fine (main)	000 ⇔ 255	0–100%
108	131	261	Blue/yellow 24 (main)	000 ⇔ 255	0–100%
–	–	262	Blue/yellow 24 fine (main)	000 ⇔ 255	0–100%
–	132	263	White 24 (main)	000 ⇔ 255	0–100%
–	–	264	White 24 fine (main)	000 ⇔ 255	0–100%
109	133	265	Red/cyan 25 (main)	000 ⇔ 255	0–100%
–	–	266	Red/cyan 25 fine (main)	000 ⇔ 255	0–100%
110	134	267	Green/magenta 25 (main)	000 ⇔ 255	0–100%
–	–	268	Green/magenta 25 fine (main)	000 ⇔ 255	0–100%
111	135	269	Blue/yellow 25 (main)	000 ⇔ 255	0–100%
–	–	270	Blue/yellow 25 fine (main)	000 ⇔ 255	0–100%
–	136	271	White 25 (main)	000 ⇔ 255	0–100%
–	–	272	White 25 fine (main)	000 ⇔ 255	0–100%
112	137	273	Red/cyan 26 (main)	000 ⇔ 255	0–100%
–	–	274	Red/cyan 26 fine (main)	000 ⇔ 255	0–100%

B	S	A	Function	Value	Percent/Setting
113	138	275	Green/magenta 26 (main)	000 ⇔ 255	0–100%
–	–	276	Green/magenta 26 fine (main)	000 ⇔ 255	0–100%
114	139	277	Blue/yellow 26 (main)	000 ⇔ 255	0–100%
–	–	278	Blue/yellow 26 fine (main)	000 ⇔ 255	0–100%
–	140	279	White 26 (main)	000 ⇔ 255	0–100%
–	–	280	White 26 fine (main)	000 ⇔ 255	0–100%
115	141	281	Red/cyan 27 (main)	000 ⇔ 255	0–100%
–	–	282	Red/cyan 27 fine (main)	000 ⇔ 255	0–100%
116	142	283	Green/magenta 27 (main)	000 ⇔ 255	0–100%
–	–	284	Green/magenta 27 fine (main)	000 ⇔ 255	0–100%
117	143	285	Blue/yellow 27 (main)	000 ⇔ 255	0–100%
–	–	286	Blue/yellow 27 fine (main)	000 ⇔ 255	0–100%
–	144	287	White 27 (main)	000 ⇔ 255	0–100%
–	–	288	White 27 fine (main)	000 ⇔ 255	0–100%
118	145	289	Red/cyan 28 (main)	000 ⇔ 255	0–100%
–	–	290	Red/cyan 28 fine (main)	000 ⇔ 255	0–100%
119	146	291	Green/magenta 28 (main)	000 ⇔ 255	0–100%
–	–	292	Green/magenta 28 fine (main)	000 ⇔ 255	0–100%
120	147	293	Blue/yellow 28 (main)	000 ⇔ 255	0–100%
–	–	294	Blue/yellow 28 fine (main)	000 ⇔ 255	0–100%
–	148	295	White 28 (main)	000 ⇔ 255	0–100%
–	–	296	White 28 fine (main)	000 ⇔ 255	0–100%

Operation

Color Chart

DMX Value	Function	Red Value	Green Value	Blue Value	White Value
000	No function	N/A	N/A	N/A	N/A
001 ⇔ 002	2700K	R: 255	G: 175	B: 0	W: 50
003 ⇔ 004	3200K	R: 243	G: 211	B: 0	W: 55
005 ⇔ 006	4000K	R: 177	G: 177	B: 0	W: 100
007 ⇔ 008	4200K	R: 251	G: 255	B: 8	W: 145
009 ⇔ 010	5600K	R: 109	G: 146	B: 0	W: 210
011 ⇔ 012	6500K	R: 106	G: 157	B: 12	W: 211
013 ⇔ 014	7500K	R: 66	G: 127	B: 11	W: 255
015	Blue	R: 0	G: 0	B: 255	W: 0
016 ⇔ 051	Blue to cyan	R: 0	G: +	B: 255	W: 0
052	Cyan	R: 0	G: 255	B: 255	W: 0
053 ⇔ 088	Cyan to green	R: 0	G: 255	B: -	W: 0
089	Green	R: 0	G: 255	B: 0	W: 0
090 ⇔ 125	Green to yellow	R: +	G: 255	B: 0	W: 0
126	Yellow	R: 255	G: 255	B: 0	W: 0
127 ⇔ 162	Yellow to red	R: 255	G: -	B: 0	W: 0
163	Red	R: 255	G: 0	B: 0	W: 0
164 ⇔ 200	Red to magenta	R: 255	G: 0	B: +	W: 0
201	Magenta	R: 255	G: 0	B: 255	W: 0
202 ⇔ 238	Magenta to blue	R: -	G: 0	B: 255	W: 0
239	Blue	R: 0	G: 0	B: 255	W: 0
240 ⇔ 247	Color fade, fast to slow	N/A	N/A	N/A	N/A
248 ⇔ 255	Color snap, fast to slow	N/A	N/A	N/A	N/A

Strobe Chart

DMX Value	Function	DMX Value	Function
000 ⇔ 019	Off	145 ⇔ 149	On
020 ⇔ 024	On	150 ⇔ 164	Random 0–100% strobe, fast to slow
025 ⇔ 064	Strobe, fast to slow	165 ⇔ 169	On
065 ⇔ 069	On	170 ⇔ 184	Pulse strobe 1, fast to slow
070 ⇔ 084	100–0% strobe , fast to slow	185 ⇔ 189	On
085 ⇔ 089	On	190 ⇔ 204	Random pulse strobe, fast to slow
090 ⇔ 104	0–100% strobe, fast to slow	205 ⇔ 209	On
105 ⇔ 109	On	210 ⇔ 224	100–0–100% strobe, fast to slow
110 ⇔ 124	Random strobe, fast to slow	225 ⇔ 229	On
125 ⇔ 129	On	230 ⇔ 244	Pulse strobe 2, fast to slow
130 ⇔ 144	Random 100–0% strobe, fast to slow	245 ⇔ 255	On

Control Chart

DMX Value	Function	DMX Value	Function
000 ⇔ 009	No function	115 ⇔ 119	Preset color HTP off
010 ⇔ 014	Blackout on pan/tilt	120 ⇔ 124	Fan mode ECO
015 ⇔ 019	Reserved for future use	125 ⇔ 129	Fan mode full
020 ⇔ 024	RGBW color mixing	130 ⇔ 134	Fan mode auto
025 ⇔ 029	CMY color mixing	135 ⇔ 139	Dimmer mode fast
030 ⇔ 034	Combine main and ring	140 ⇔ 144	Dimmer mode smooth
035 ⇔ 039	Disable combine main and ring	145 ⇔ 149	Dimmer curve linear
040 ⇔ 044	Defrost fan on	150 ⇔ 154	Dimmer curve square
045 ⇔ 049	Defrost fan off	155 ⇔ 159	Dimmer curve inverse square
050 ⇔ 054	Reset pan	160 ⇔ 164	Dimmer curve S-curve
055 ⇔ 059	Reset tilt	165 ⇔ 169	WHITE mode
060 ⇔ 064	Zoom reset	170 ⇔ 174	FULL mode
065 ⇔ 066	TV reset mode	175 ⇔ 179	Single-color calibration off
067 ⇔ 069	Normal reset mode	180 ⇔ 184	Single-color calibration on
070 ⇔ 074	Reset all	185 ⇔ 186	PWM 600 Hz
075 ⇔ 079	Reserved	187 ⇔ 188	PWM 1200 Hz
080 ⇔ 084	Reserved	189 ⇔ 190	PWM 2000 Hz
085 ⇔ 089	Reverse pan	191 ⇔ 192	PWM 4000 Hz
090 ⇔ 094	Reverse tilt	193 ⇔ 194	PWM 6000 Hz
095 ⇔ 099	Disable reverse pan	195 ⇔ 196	PWM 15000 Hz
100 ⇔ 104	Disable reverse tilt	197 ⇔ 239	No function
105 ⇔ 109	Disable reverse pan/tilt	240 ⇔ 247	Calibration on
110 ⇔ 114	Preset color HTP on	248 ⇔ 255	Calibration off



Preset Color HTP

When preset color HTP is on, manual color controls may be used at the same time as preset color controls.

When preset color HTP is off, preset color controls will override all manual color controls.

Operation

Settings Configuration

Pan Reverse

To set the orientation of the pan:

1. Go to the **Setup** main level.
2. Select the **Pan Reverse** option.
3. Select from **NO** (normal pan motion), or **YES** (reversed pan motion).

Tilt Reverse

To set the orientation of the tilt:

1. Go to the **Setup** main level.
2. Select the **Tilt Reverse** option.
3. Select from **NO** (normal tilt motion), or **YES** (reversed tilt motion).

Zoom Reverse

To set the orientation of the zoom:

1. Go to the **Setup** main level.
2. Select the **Zoom Reverse** option.
3. Select from **NO** (normal zoom), or **YES** (reversed zoom).

Screen Reverse

To set the orientation of the display:

1. Go to the **Setup** main level.
2. Select the **Screen Reverse** option.
3. Select from **NO** (right-side up), **YES** (upside-down), or **AUTO** (automatic orientation).

Pan Angle

To set the maximum angle of the pan:

1. Go to the **Setup** main level.
2. Select the **Pan Angle** option.
3. Select from **540** (540°), **360** (360°), or **180** (180°).

Tilt Angle

To set the maximum angle of the tilt:

1. Go to the **Setup** main level.
2. Select the **Tilt Angle** option.
3. Select from **260** (260°), **180** (180°), or **90** (90°).

Black out on Movement

To set the product to black out while the pan/tilt, color wheel, or gobo wheels are moving:

1. Go to the **Setup** main level.
2. Select the **BL. O. P/T Move** option.
3. Select from **NO** or **YES**.

Swap Pan and Tilt

To swap the controls for the pan and tilt:

1. Go to the **Setup** main level.
2. Select the **Swap XY** option.
3. Select from **NO** (pan controls pan, tilt controls tilt) or **YES** (pan controls tilt, tilt controls pan).

Lock Screen

To lock the buttons and touch screen:

1. Go to the **Setup** main level.
2. Select the **Lock Screen** option.
3. Select from **NO** or **YES**.

WDMX Reset

To reset the WDMX connection:

1. Go to the **Setup** main level.
2. Select the **WDMX Reset** option.
3. Select from **NO** or **YES**.

Display Backlight Timer

To set how long before an inactive display will turn off:

1. Go to the **Setup** main level.
2. Select the **Backlight Timer** option.
3. Select the length of the backlight timer, from **30S** (30 seconds), **1M** (1 minute), **5M** (5 minutes), or **ON** (always on).

Loss of Data

To select how the product will respond to a loss of the control signal:

1. Go to the **Setup** main level.
2. Select the **Loss of Data** option.
3. Select from **Hold** (holds last signal received) or **Close** (blacks out fixture).

Fan Speed

To set the speed of the fans:

1. Go to the **Setup** main level.
2. Select the **Fans** option.
3. Select from **Auto** (fan speed set according to product temperature), **Full** (maximum speed), or **ECO** (quiet fans mode).

Color Mixing Mode

To set the color mixing mode:

1. Go to the **Setup** main level.
2. Select the **C Mixing Mode** option.
3. Select **RGBW** (additive mode: red, green, blue, and white), or **CMY** (subtractive mode: red controls cyan, green controls magenta, blue controls yellow).

Dimmer Curve

To set the dimmer curve:

1. Go to the **Setup** main level.
2. Select the **Dimmer Curve** option.
3. Select the **Linear**, **Square**, **I Squa**, or **SCurve**.

Dimmer Speed

To set the dimmer speed:

1. Go to the **Setup** main level.
2. Select the **Dimmer Speed** option.
3. Select **Smooth** or **Fast**.

Pulse Width Modulation

To adjust the frequency of the pulse width modulation:

1. Go to the **Setup** main level.
2. Select the **PWM Options** option.
3. Select **600Hz**, **1200Hz**, **2000Hz**, **4000Hz**, **6000Hz**, or **15000Hz**.

Color Balance

To set the maximum values of a given color in the mix:

1. Go to the **Setup** main level.
2. Select the **Color Balance** option.
3. Select from **Red**, **Green**, **Blue**, or **White** options.
4. Select a value from **100–255**

Calibrated White

To set the white mode:

1. Go to the **Setup** main level.
2. Select the **Calibrated White** option.
3. Select from **ON** (uses the factory-calibrated white balance), **OFF** (uses the maximum white values), or **Custom** (uses the custom white values defined under [White Balance](#))

Operation

White Balance

To set the custom white balance:

1. Go to the **Setup** main level.
2. Select the **White Balance** option.
3. Select from **Red, Green, Blue, or White**.
4. Select a value from **000–255**.

Merge Channel

To merge the zoom functions:

1. Go to the **Setup** main level.
2. Select the **Merge Channel** option.
1. Select from **NO** or **YES**.

Preset Select

This option saves three different preset menu option configurations. To record and set these presets, follow the instructions below:

1. Go to the **Setup** main level.
2. Select the **Preset Select** option.
3. Select from **PRESET A, PRESET B, or PRESET C**.
4. The product will reset. Any changes made to the menu options will be saved to this preset.
 - Default is **PRESET A**. Once changes are made inside **PRESET A**, those changes are saved to **PRESET A** without having to do anything.
 - To create a new preset, highlight and select **PRESET SELECT**. Highlight **PRESET B** or **PRESET C** and press **<ENTER>**. The product will reset automatically. Go back and make the necessary changes in the menu. This will automatically save to the present preset.



Preset Sync

To sync all menu presets to other Maverick Storm 3 BeamWashes:

1. Go to the **Setup** main level.
2. Select the **Preset Sync** option.
3. Select **NO** or **YES**.
 - To sync other Maverick Storm 3 BeamWashes, connect those products via DMX cable.
 - The product can be in any control mode except WDMX. ArtNet, DMX, sACN are all acceptable.
 - All menu options are transferred, including the DMX address. Only the IP address is not affected in the other products.



Only connect Maverick Storm 3 BeamWash.

USB Update

To enable or disable software update using USB:

1. Go to the **Setup** main level.
2. Select the **USB Update** option.
3. Select **NO** (disables software update through USB) or **YES** (enables software update through USB).



See the [USB Software Update](#) section for the detailed instructions on how to update the Maverick Storm 3 BeamWash software using a USB-C connection.

TV Reset Mode

To enable or disable the TV Mode:

1. Go to the **Setup** main level.
2. Select the **TV Reset Mode** option.
3. Select from **NO** or **YES**.

Reset function

To reset all functions as if from startup:

1. Go to the **Setup** main level.
2. Select the **Reset Function** option.
3. Select from **Pan/ Tilt, Zoom, or All**.
4. Select from **NO** or **YES**.

Factory Reset

To reset the product to factory settings:

1. Go to the **Settings** main level.
2. Select the **Factory Settings** option.
3. Select **NO** (to cancel) or **YES** (to reset the product configuration).

Test Mode

Auto Test

To have the Maverick Storm 3 BeamWash automatically test all functions one after the other:

1. Go to the **Test Mode** main level.
2. Select the **Auto Test** option.

Manual Test

To manually test an individual function of the Maverick Storm 3 BeamWash:

1. Go to the **Test Mode** main level.
2. Select the **Manual Test** option.
3. Select a function to test, from **Pan, Tilt, P/T Speed, Red1, Green1, Blue1, CTC1, Color1, Pattern1, LED Macro1, LED Ma. Speed1, LED Ma. Fade1, Background1, Background1 Dim., Dimmer1, Shutter1, Red2, Green2, Blue2, White2, CTC2, Color2, Pattern2, LED Macro2, LED Ma. Speed2, LED Ma. Fade2, Background2, Background2 Dim, Dimmer2, Shutter2, Control, Zoom1, or Zoom2.**
4. Increase or decrease the value of the selected function from **000–255** to test it.

System Information

The information section of the menu displays statistics and the current status of the product's various functions. To view this information:

1. Go to the **Sys Info** main level.
2. Select from the **Fixture Information, Fan Information, Error Information, or Channel Information** options.
3. Use **<UP>** and **<DOWN>** to view all information.

Offset Mode

The Offset mode provides fine adjustments for the home position of every moving part in the optical path as well as the pan and tilt movements. To adjust these options and prevent borders showing or reduction of the light output:

1. From the main level screen, press and hold **<MENU>** until the passcode screen appears.
2. Enter the passcode: **0920** and press **<ENTER>**.
3. Select the "zero" position to adjust, from **PAN, TILT, ZOOM1, ZOOM2, MAC4, MAC5, MAC6, RDM4, RDM5, RDM6.**
4. Adjust the "zero" position for the selected function from **000–255.**

Operation

Web Server

The Maverick Storm 3 BeamWash Web Server can be accessed by any computer on the same network as the product. It allows network access to system information, settings such as control setup, manual testing of all functions, firmware updates, and the ability to change the Web Server password.

1. Connect the product to power, and set the [Control Mode](#) to **ArtNet** and the [IP Mode](#) to **Static**.
2. Connect the product to a Windows computer with a network cable.
3. On the computer, set the first value of the IP address of the new network to match the first value of the IP address of the product. The IP address of the product is displayed on the [Home Screen](#).
4. Enter the IP address of the product into the URL bar of a web browser on the computer.
5. Enter both the User Name and Password as **admin** to log in.

Information

The Information page on the Web Server displays the current settings and the system information of the Maverick Storm 3 BeamWash.

Setup

The Setup page on the Web Server provides options for control, similar to the **Setup** menu on the product. Click **Save Settings** to send the new configuration to the product.

Manual Test

The Manual Test page on the Web Server allows all output functions of the product to be controlled through the browser. To set all functions back to default, click **Reset**.

Firmware Update

The Upgrade page on the Web Server allows the product to be updated with the latest firmware. Go to <https://www.chauvetprofessional.com> to download firmware updates.

Security

The Security page on the Web Server gives the option to change the password to the connected product's web server. Enter the old password (**admin**, by default) and the new password twice, then click **Save Settings** to change the password.

5. Maintenance

Product Maintenance

Dust build-up reduces light output performance and can cause overheating. This can lead to reduction of the light source's life and/or mechanical wear. To maintain optimum performance and minimize wear, clean all lighting products at least twice a month. However, be aware that usage and environmental conditions could be contributing factors to increase the cleaning frequency.

To clean the product, follow the instructions below:

1. Unplug the product from power.
2. Wait until the product is at room temperature.
3. Use a vacuum (or dry compressed air) and a soft brush to remove dust collected on the external surface/vents.
4. Clean all transparent surfaces with a mild soap solution, ammonia-free glass cleaner, or isopropyl alcohol.
5. Apply the solution directly to a soft, lint free cotton cloth or a lens cleaning tissue.
6. Softly drag any dirt or grime to the outside of the transparent surface.
7. Gently polish the transparent surfaces until they are free of haze and lint.



Always dry the transparent surfaces carefully after cleaning them.



Do not spin the cooling fans with compressed air. Damage may occur.

Torque Measurements

To maintain the IP rating when reassembling the product, use the given torque measurements for each of the following screws and bolts:

Fixture Parts	Torque Rating (Kgf.cm)	Torque Rating (lgb.in)
Screws inside feet	15.3	13.3
Base screws around outside (not the feet)	53	46
Base screws in middle	89.7	77.8
Omega bracket holder	12.2	10.6
Front and rear base cover	25.5	22.1
Screws around power and data ports	3.6	3
Fuse	10.7	9.2
Center of yoke plate	25.5	22.1
Arm cover screws	25.5	22.1
Allen Key screws holding in front lens cover	15.2	13.2
Allen Key screws next to heat pipes on the back	20.3	17.7
Allen Key screws head covers	25.5	22.1

Vacuum Test Measurements

To ensure that the product has been reassembled correctly, use the IP Tester from Chauvet Professional to check the following data has the given measurements for the given method:

Parameters	Values
Method	Positive
Test pressure	2.18 kPa
Test duration	60 seconds
PASS state leak pressure	<0.02 kPa

Transporting on Truss or Racks

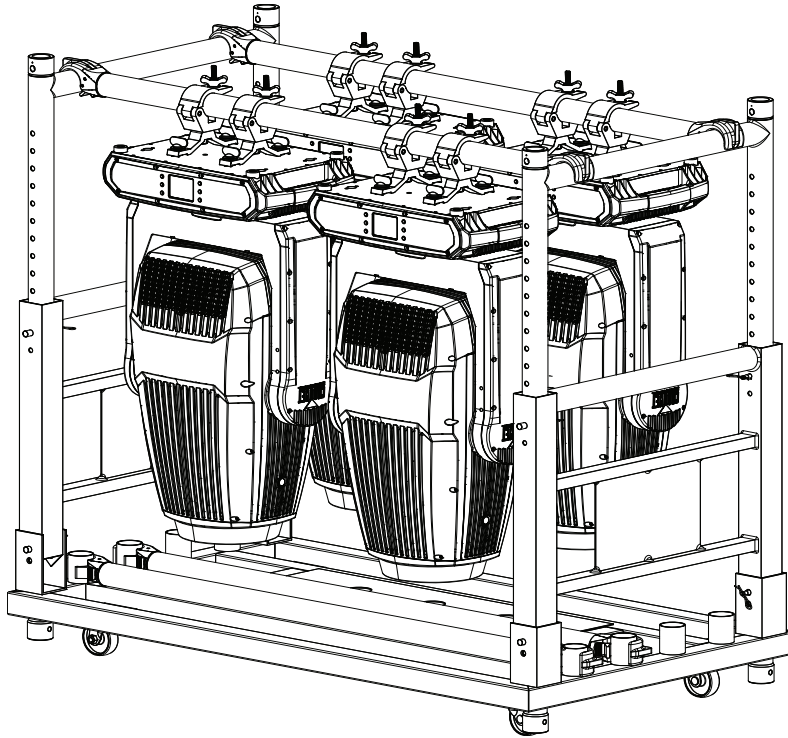

When transporting fixtures in pre-rigged truss and transportation racks, mount fixtures in the vertical position with the lenses facing down and the pan and tilt locks engaged. This is to prevent undue stress on the tilt locks and limit the amount of off-axis bounce on internal components.



The products depicted in this graphic are displayed for illustrative purposes only.

6. Technical Specifications

Dimensions and Weight

Length	Width	Height	Weight
18.98 in (482 mm)	11.93 in (303 mm)	23.74 in (603 mm)	82.45 lb (37.4 kg)

Note: Dimensions in inches are rounded.

Power

Power Supply Type	Range	Voltage Selection
Switching (internal)	100 to 240 VAC, 50/60 Hz	Auto-ranging

Parameter	100 V, 60 Hz	120 V, 60 Hz	208 V, 60 Hz	230 V, 50 Hz	240 V, 60 Hz
Consumption	1511 W	1478 W	1443 W	1442 W	1423 W
Operating Current	15.12 A	12.25 A	7.0 A	6.31 A	6 A
Fuse/Breaker	T25 A, 750 V	T25 A, 750 V	T25 A, 750 V	T25 A, 750 V	T25 A, 750 V

Power I/O	U.S./Worldwide	UK/Europe
Power Input Connector	Seetronic Powerkon IP65	Seetronic Powerkon IP65
Power Cable Plug	Bare wire	Bare wire

Light Source

	Type	Color	Quantity	Power	Current	Lifespan
Main	LED	Quad-color RGBW	28	45 W	3 A	50,000 hours
Outer Ring	LED	Tri-color RGB	256	0.2 W	20 mA	50,000 hours

Photometrics

Beam Angle	Field Angle	Cutoff Angle	Zoom Range
3.9° to 36.4°	6.7° to 48.7°	7.9° to 53.8°	3.9° to 53.8°

Illuminance (3.3°)	Illuminance (53.8°)	Lumens (source)	Lumens (output)	Temperature
61,338 lux @ 5m	2211 lux @ 5m	25,800	18,594	2700 to 8000 K

Thermal

Maximum External Temperature	Cooling System
113 °F (45 °C)	Fan-assisted Convection

Control

DMX I/O Connector	Ethernet I/O Connector
5-pin IP-rated XLR	Neutrik IP-rated RJ45

Protocol	Single Mode	Dual Mode Movement	Dual Mode Pixel
DMX, Art-Net/ sACN/Kling-Net	20Ch, 32Ch, 38Ch, 180Ch, 336Ch, 416Ch, or 424Ch	12Ch, 35Ch, or 46Ch	120Ch, 148Ch, or 296Ch

Ordering

Product Name	Item Name	Item Code	UPC Number
Maverick Storm 3 BeamWash	MAVERICKSTORM3BEAMWASH-2	08012035	781462226534



UL 1573
CSA C22.2 No. 166
E113093



Contact Us

General Information	Technical Support
Chauvet World Headquarters	
Address: 3360 Davie Rd., Suite 509 Davie, FL 33314 Voice: (954) 577-4455 Fax: (954) 929-5560 Toll Free: (800) 762-1084	Voice: (844) 393-7575 Fax: (954) 756-8015 Email: chauvetcs@chauvetlighting.com Website: www.chauvetprofessional.com
Chauvet U.K.	
Address: Pod 1 EVO Park Little Oak Drive, Sherwood Park Nottinghamshire, NG15 0EB UK Voice: +44 (0) 1773 511115 Fax: +44 (0) 1773 511110	Email: UKtech@chauvetlighting.eu Website: www.chauvetprofessional.eu
Chauvet Benelux	
Address: Stokstraat 18 9770 Kruishoutem Belgium Voice: +32 9 388 93 97	Email: BNLtech@chauvetlighting.eu Website: www.chauvetprofessional.eu
Chauvet France	
Address: 3, Rue Ampère 91380 Chilly-Mazarin France Voice: +33 1 78 85 33 59	Email: FRtech@chauvetlighting.fr Website: www.chauvetprofessional.eu
Chauvet Germany	
Address: Bruno-Bürgel-Str. 11 28759 Bremen Germany Voice: +49 421 62 60 20	Email: DEtech@chauvetlighting.de Website: www.chauvetprofessional.eu
Chauvet Mexico	
Address: Av. de las Partidas 34 - 3B (Entrance by Calle 2) Zona Industrial Lerma Lerma, Edo. de México, CP 52000 Voice: +52 (728) 690-2010	Email: servicio@chauvet.com.mx Website: www.chauvetprofessional.mx

Warranty & Returns

For warranty terms and conditions and return information, please visit our website.

For customers in the United States and Mexico: www.chauvetlighting.com/warranty-registration.

For customers in the United Kingdom, Republic of Ireland, Belgium, the Netherlands, Luxembourg, France, and Germany: www.chauvetlighting.eu/warranty-registration.